

# Application of Electrochemical Impedance Spectroscopy on Different Battery Circuits

Sattler Johannes, Alexander Bauder, Dirk Schneider, Norbert Wagner, K. Andreas Friedrich

johannes.sattler@dlr.de

For the operation of a battery pack, the cell state estimation plays a central role. For that, enough information about the current charge condition (SoC, state of charge) and the health status (SoH, state of health) of the individual cells or cell strings must be available. One way to draw out conclusions about the state of charge and health provides the electrochemical impedance spectroscopy (EIS) [1]. The test cells are thereby stimulated with an alternating current signal, and the resulting voltage signal is detected. These results in cell impedances, which are addicted to the signal frequencies and the respective cell states. This poster shows an experimental platform which uses the EIS to detect asymmetries in SoC and/or SoH on circuited cells. For that, the behavior of the amplitudes and frequencies of the signals should be analyzed, because for the calculation of the precise impedance, these factors are crucial. Thereby the required alternating current and voltage signals are acquired and analyzed separately for each single cell. As cell type lithium iron-phosphate round cells of the size 18650 are used. The investigations are made on a series circuit (Fig.1) made up of three cells and on a parallel circuit made up of two strings, each having two cells in series. It shows that both a series and a parallel connection within the working range the experimental platform impedances of individual cells can be determined. For these cases, differences in state of charge and state of health can be highlighted and assigned to the respective cells.

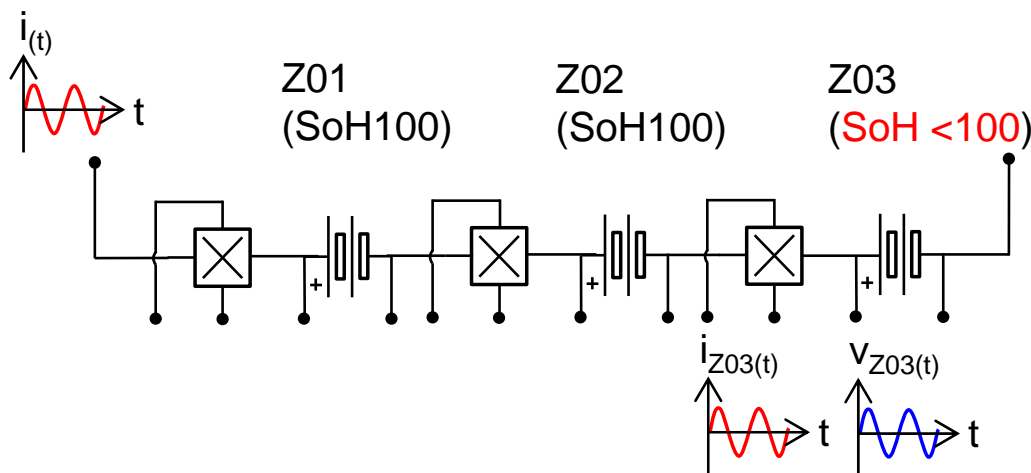

Fig.1: Series circuit made of three batteries

[1] Dirk Schneider, Influence of electrochemical impedance spectroscopy on state of charge and state of health of lithium/ion cells, University of Stuttgart, 2013