



SolarPACES 2013

## Thermochemical energy storage in kW-scale based on $\text{CaO}/\text{Ca}(\text{OH})_2$

M. Linder\*, Chr. Roßkopf, M. Schmidt, A. Wörner

*Institute of Technical Thermodynamics, German Aerospace Center (DLR), Germany*

---

### Abstract

In order to investigate thermochemical energy storage in larger scale, a test bench as well as a reactor containing around 20 kg of reaction material has been built and brought into operation. This investigation is based on the reversible decomposition reaction of calcium hydroxide, due to its wide availability, high reaction enthalpy and promising temperature range for CSP plants. Additionally, a developed simulation tool was used to analyze the experimental results. The comparison of the discharging processes showed a good agreement but also revealed thermal losses due to the experimental setup and the operation mode of the thermochemical storage. Therefore, first operation strategies of thermal energy storages based on chemical reactions can be derived.

© 2013 The Authors. Published by Elsevier Ltd. This is an open access article under the CC BY-NC-ND license (<http://creativecommons.org/licenses/by-nc-nd/3.0/>).

Selection and peer review by the scientific conference committee of SolarPACES 2013 under responsibility of PSE AG.

Final manuscript published as received without editorial corrections.

*Keywords:* Thermochemical Energy Storage; Calcium Hydroxide; Modelling; kW-scale Test Bench

---

### 1. Introduction

Due to the wide availability at low cost and its favorable temperature range, the reversible decomposition reaction of calcium hydroxide is a promising candidate for thermochemical heat storage:

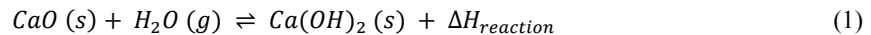

---

\* Corresponding author. Tel.: +49 711 6862 8034; fax: +49 711 6862 632.

E-mail address: [marc.linder@dlr.de](mailto:marc.linder@dlr.de)

In literature and previous works, the material has been investigated in detail on a material or small scale basis and a complete reversibility and cycle stability of the reaction system has been demonstrated [1-5]. Besides that, the fast effective reaction kinetics, the high reaction enthalpy of 99.5 kJ/mol [1] and the adjustable temperature range between 410°C and 600°C make the system a promising candidate for an application in concentrated solar power plants. However, regarding the development of thermochemical storage reactors, physical bulk properties (e.g. gas permeability) and their impact on the operation characteristics of storage systems have to be investigated and understood. Since those effects can only be experimentally investigated with larger scale reactors and respective test-bench equipment, a multifunctional test-bench for thermochemical energy storage has been developed and brought into operation.

## 2. Experimental set up

### 2.1. Reactor

The plate heat exchanger shown in Fig. 1, left was designed to investigate thermochemical heat storage based on the CaO/Ca(OH)<sub>2</sub> material. The heat transfer fluid (HTF), in this case air, is flowing inside ten thermo-shelves while the storage material is placed in the 20 mm wide channels between these plates. Due to the physical separation between the HTF and the reaction bed the pressure of the reaction gas is independent from the HTF. This indirectly operated reactor concept offers the possibility to investigate the thermochemical storage tank in various operation modes.



Fig. 1. Left: Indirectly operated thermochemical storage reactor (top cover not shown); Right: Picture of multifunctional test bench

The heat is transferred from or into the reaction material bulk along the 800 mm long shelves before the HTF leaves the reactor at the opposite side. The reaction gas, water vapor, enters the reactor from the top and is distributed in the whole reaction chamber due to a gap between the vapor inlet at the top cover (not shown in Fig. 1) and the bed surface. This cross flow arrangement between the HTF and the reaction gas was chosen to realize a large heat transfer area from the HTF to the bulk while the pressure drop of the reaction gas over the only 200 mm depth bed was minimized. A detailed description of the reactor and its geometry can be found in [6]

The reactor can hold up to 25 kg of Ca(OH)<sub>2</sub>. Based on an assumed temperature difference of 200 K between the air in- and outlet, the heat transfer area of 4.25 m<sup>2</sup> and a maximum volume flow of 150 Nm<sup>3</sup>/h, peak thermal power of 10 kW can be realized. High temperature alloys have been chosen to withstand temperatures of up to 600 °C. The reaction gas side can be exposed to pressures between 0 and 2.5 bar in order to analyse the influence on the operation characteristics. For the experiments given below, an amount of 20.03 kg of commercially available

$\text{Ca(OH)}_2$  from the HeidelbergerCement Group was used. According to the supplier, the purity is around 97% and the particle size distribution is  $d_{50} = 5 \mu\text{m}$ .

## 2.2. Test bench

In order to be able to investigate different thermochemical reactors a multifunctional test bench has been designed and brought into operation at DLR (see Fig. 1, right and Fig. 2) [7]. The test bench can be divided into four functional parts: the HTF supply, the reaction gas supply, the storage reactor test track and the cooling unit.

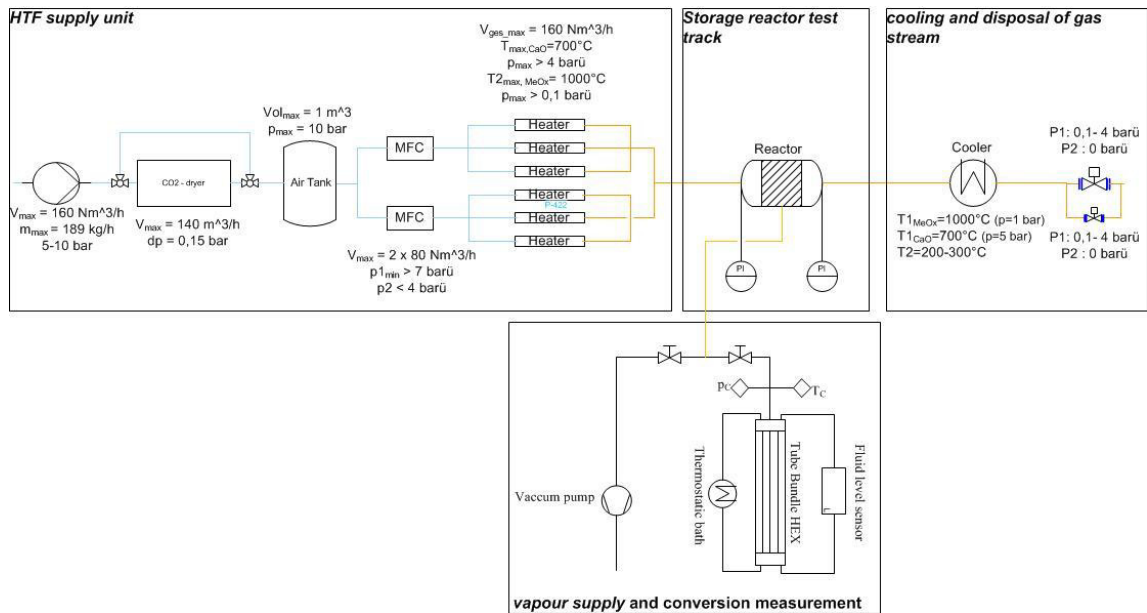

Fig. 2. Process flow diagram of the test bench with an integrated indirectly operated reactor

### HTF Supply Unit

Ambient air, serving as HTF, is compressed and stored in the buffer tank at 10 bars. Optional, the CO<sub>2</sub> content of the compressed air can be reduced by a CO<sub>2</sub>-adsorption dryer in case of directly operated reactors. The airflow is divided into two heating sections and each section is adjustable by mass flow controllers between 8 and 80 Nm<sup>3</sup>/h at a maximum pressure of 5 bars. Three electrical heaters in each section are able to heat up the air flow to a maximum temperature of 1000 °C.

### Storage reactor test track

Different storage reactors can be connected to the HTF supply unit via a flange connection. In order to monitor and balance the behavior of the reaction bed, temperatures and pressures at the reactor inlet and outlet are measured. Additionally, 21 thermocouples (type K; class 1; diameter 2 mm) inside the reaction bed can be connected to the monitoring unit. The thermocouples used below are all located in one channel at identical depth in the material bulk but different positions along the length of the reaction bed.

### Reaction gas and conversion measurement

In order to handle the reaction gas and to monitor the rate of reaction an evaporation/ condensation unit is connected. On the tube side of this heat exchanger, a thermo fluid tempered externally between 5-120°C is maintaining the water temperature and water vapor pressure, respectively. The vapor coming from the reactor thus condenses at the tubes and remains in the chasing. The change in the water level is continuously measured via a fluid level sensor and corresponds to the rate of reaction in the reactor. For the hydration reactions shown below, the temperature of the thermo fluid is set to different evaporation temperatures. As soon as the valve between the heat exchanger and the reactor is opened the reaction is initiated.

### Cooling and disposal of the HTF stream

During the discharging process, the outlet temperature of the HTF can reach up to 600 °C. This hot gas stream is cooled down to around 200°C by a gas water heat exchanger before the control valves and the chimney. The two control valves offer the possibility to adjust the gas pressure of the HTF corresponding to the gas flow velocity in the storage test track.

### 2.3. Experimental procedure

At the beginning of a hydration cycle only CaO is present in the storage reactor. The set-up is preheated by the HTF until isothermal conditions are reached. The air mass flow and the inlet temperature are kept constant for the entire procedure. The reaction gas side is evacuated in order to remove inert gases and the respective steam pressure in the evaporator is adjusted. In order to initiate the hydration reaction the valve between the evaporator and the reactor is opened enabling the water vapor to enter the reaction chamber. The exothermic reaction starts and can be observed with the measured bed temperatures, the air outlet temperature and the rate of conversion. The vapor pressure is kept constant until the material has reacted completely resulting in a constant water level. Accordingly, the temperatures start to decrease until the whole system reaches the initial conditions of 340°C again and the discharge cycle is completed.

In order to investigate the influence of the HTF mass flow on the reaction, two hydration procedures with different mass flows have been carried out. Additionally, the vapor pressure was changed to observe the influence on the reachable temperature in the reactor.

### 2.4. Discharge of the storage reactor

One discharging cycle was performed according to the procedure described in chapter 2.3. The HTF supply was adjusted to a mass flow to 50 Nm<sup>3</sup>/h and inlet temperature of 350 °C. An evaporation temperature of 98 °C corresponding to a vapor pressure of 0.9 bars was set in the heat exchanger (compare Fig. 2). These initial parameters are defined as operation mode 1 (indices: om1). Fig. 3, left shows the water vapor pressure and the temperatures (T\_1\_om1; T\_5\_om1; T\_11\_om1; T\_13\_om1) inside the storage material bed along the HTF flow direction. As soon as the valve between reactor and evaporator was opened the pressure in the system equalizes. Simultaneously, with the presence of water vapor, the bed temperatures raise from 340 °C up to 490 °C. Due to better cooling at the entrance of the reactor, after 17 min most of the material in this area has already reacted indicated by the temperature decrease of T\_1\_om1. Along the flow direction of the HTF, a reaction front is formed that is visualized by the subsequent temperature drop at T\_5\_om1 and T\_11\_om1 drop (comp. Fig. 3, left). T\_13\_om1, directly at the outlet of the reactor, keeps the equilibrium temperature of 490°C for around 118 min until also in this area most of the material has reacted. After 240 min, the whole bed has cooled down to the initial temperature of 340°C again and the cycle is completed.

The air in- and out-let temperature as well as the change in the fluid level is shown in Fig. 3, right. The initiation of the reaction is indicated by the decrease of the water level in the evaporator. Simultaneously the air outlet temperature starts to increase until it reaches a peak of 430 °C around 42 min after initiation. At this point around 62 % of the material has reacted already, indicated by the fluid level. Due to the chosen operation mode (initial temperature is lower than equilibrium temperature), the whole reaction bed is heated up by the chemical reaction. So a

part of the chemically storage thermal energy is actually transferred to a temperature increase of the sensible mass. This also leads to a difference between the air outlet temperature of 430°C and the much higher bed temperature of 490°C (compare Fig. 3, left). However, a temperature difference of 150K between in- and outlet temperature was reached 15 min after initiation and was hold for more than 100 min. Since during this operation mode, the inlet temperature can be kept constant and is equal to the initial temperature, the chemically stored thermal energy can be properly measured. In case of a higher initial temperature, the sensible masses of the material as well as of the reactor also account for a heat release (sensible storage).

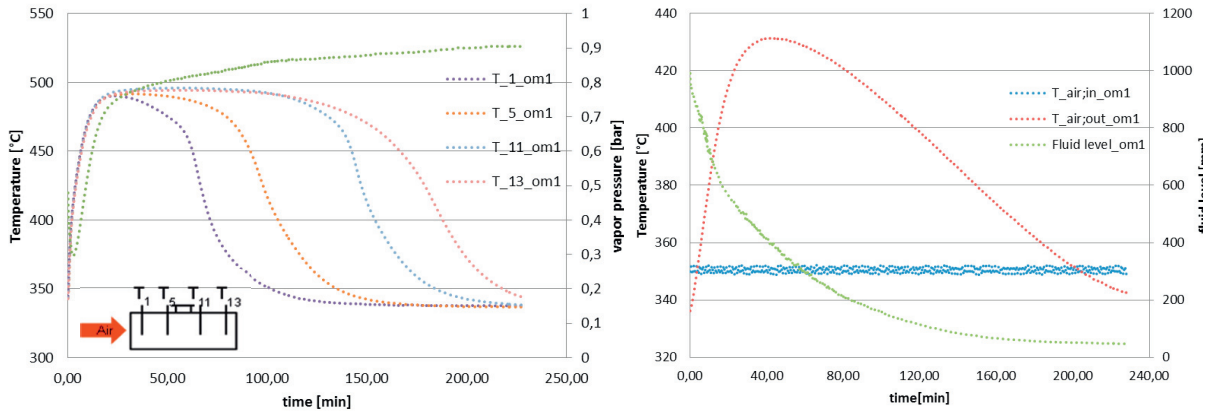

Fig. 3. Left: bed temperatures and reactor pressure during hydration procedure in operation mode 1 (om1);  
Right: Reaction bed temperatures and conversion during the hydration procedure

### 2.5. Influence of HTF mass flow on the reaction front

In order to investigate the reaction front described above in detail, an hydration reaction with 75 Nm<sup>3</sup>/h (50% increase in comparison to chapter 2.4) was performed. Additionally, the water vapor pressure was adjusted to 1,985 bars resulting in a higher equilibrium temperature in the bed. This setting is defined as operation mode two (indices: om2). The temperature and conversion trend is plotted in Fig. 4 (continuous lines) and for better comparison the values of the procedure described in 2.4 (indices: om1; dotted lines) are added.

Since the applied vapor pressure during om2 is higher, the reaction bed temperatures reach a higher maximum temperature. However, only T<sub>13\_om2</sub> located close to the HTF outlet can keep the corresponding equilibrium temperature of 540°C for around 60 min. So, due to the increased heat flux, most of the reaction bed does not reach equilibrium or only for a very short time span. Consequently, the cycle is already completed after 150 min. The increased heat flux also has an impact on the reaction front visualized by the bed temperatures (T<sub>1\_om2</sub>; T<sub>5\_om2</sub>; T<sub>11\_om2</sub>). Even though, the evolution of the bed temperature correlates to the flow direction of the HTF, the evolution of the maximum temperatures indicate that most of the reaction bed is cooled by the HTF – already after 20 min. In contrast, in operation mode 1, the temperatures (T<sub>1\_om1</sub>; T<sub>5\_om1</sub>; T<sub>11\_om1</sub>) reach the corresponding equilibrium temperature of 490°C and stay constant before they decrease subsequently.

The reaction front is experimentally indicated by the evolution of temperature signals only since a direct measurement of the local conversion is not possible. Additionally, it has to be stated that the development of this reaction front does not only depend on the HTF and the reaction gas pressure but also on geometric conditions, e.g. heat conduction distance within the bed. Since these impact factors are experimentally fixed, an analysis of the processes within the reaction bed has to be supported by simulation.

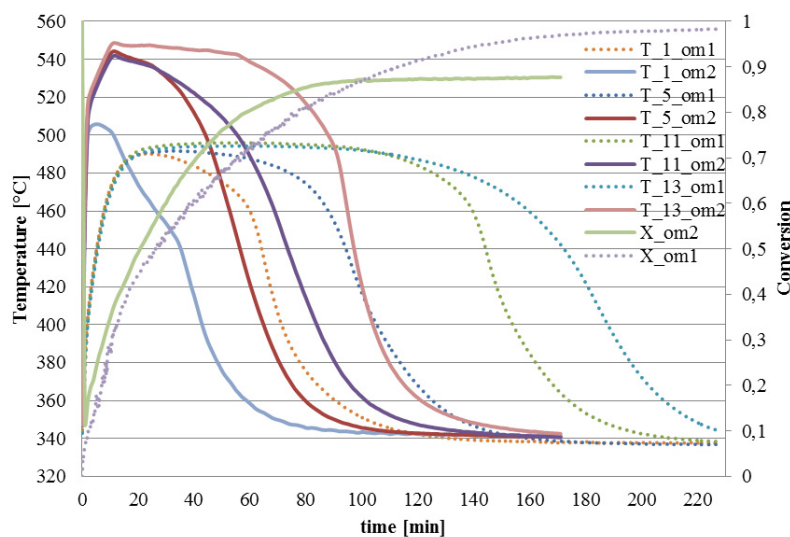

Fig. 4. Influence of HTF mass flow and reaction gas pressure on reaction front

### 3. Model description

In order to investigate the influence of crucial parameters on the performance of the thermochemical reactor, the system has been modeled using the finite element based, commercially available software COMSOL Multiphysics®. Based on the assumption of a sufficiently high permeability of the bed, an impulse balance can be neglected and therefore, a 2D-Model is able to represent the important processes within the reaction bed. This assumption is valid as long as the reaction (after balancing of the pressure, compare chapter 2.3) is limited by heat transfer constrains and the reacted gas is compensated immediately.

Based on this consideration, Fig. 5 shows a schematic of the implemented geometric model indicating its domains and boundaries. The modeling area is divided into three main parts: On the left and right side the channels for the heat transfer fluid (HTF) are modeled (flowing from bottom to top) and in the middle domain the reaction bed is represented. The governing equations, the thermodynamic equilibrium as well as the reaction kinetics for the hydration procedure can be found in [8]:

The development of the reaction gas pressure at the inlet during the hydration is implemented by the measured values of the experiments (compare Fig. 3, left). Additionally, following important parameters are used:

Bed porosity	$\varepsilon_{bed} = 0.8$
Heat conductivity within the bed	$\lambda_{bed} = 0.1 \frac{W}{mK}$
Heat transfer coefficient (Reaction bed ↔ HTF):	$U = 150 \frac{W}{m^2K}$

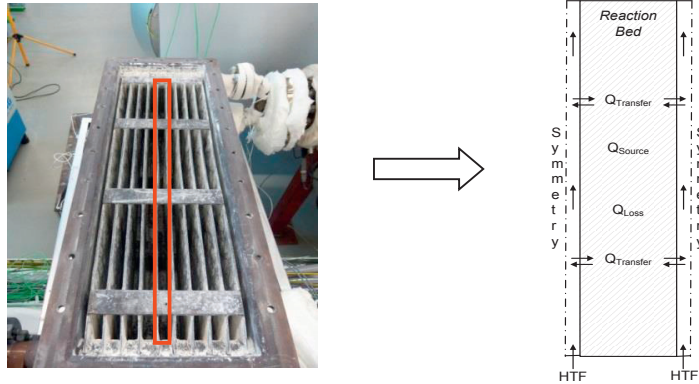

Fig. 5. Schematic of the geometric model used for the simulation of the thermochemical storage

The starting temperature  $T_{Start}$  is set to  $350\text{ }^{\circ}\text{C}$ , equivalent to the initial temperature of the experiment. An overall heat transfer coefficient of  $150\text{ W/m}^2\text{K}$  was estimated based on the heat transfer coefficient in small gaps and the contact resistance between a fine powder bulk and heat transfer surfaces. Based on the experimentally used mass flow rates, the velocities in the HTF channels are calculated. Thereby, properties of air are determined by the simulation software depending on the actual pressure and temperature data within the channel. Within the reaction bed, the positions of the thermocouples are adapted to the ones in the thermochemical reactor.

In Fig. 6 different shapes of possible reaction fronts (red: reacted material; blue: unreacted material) are shown. The mass flow of the HTF flowing through the reactor is always reduced by 50% from the left to the right. It can be seen that the sharpness of the reaction front depends directly on the thermal power that can be removed by the HTF. Therefore, the main reason for the different temperature evolutions monitored by the experiments shown above is the low thermal conductivity within the bed that reduces the dynamics of the reaction with increasing conversion.

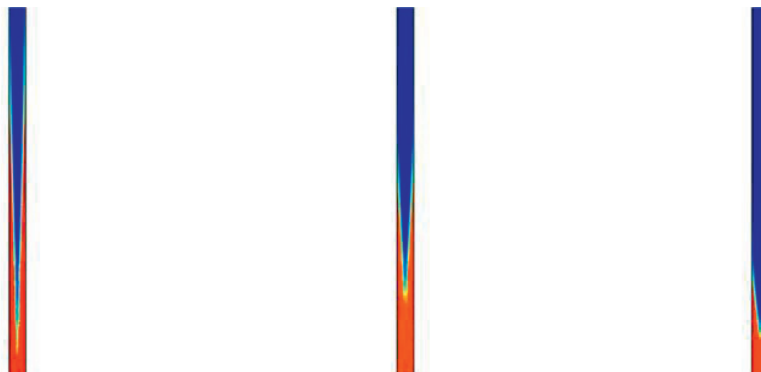

Fig. 6. Reaction front during the hydration process; left: HTF volume flow of  $75\text{ Nm}^3/\text{h}$ ; middle: HTF volume flow of  $37.5\text{ Nm}^3/\text{h}$ ; right: HTF volume flow of  $18.75\text{ Nm}^3/\text{h}$

#### 4. Simulation results and comparison

Figure 7 shows the temperature developments within the reaction bed of the simulation (dotted lines) as well as the experimentally monitored temperature curves of the reactor. It is obvious that the general trend of the respective temperature evolutions is very similar. However, the overall reaction time of the simulated hydration is much longer than in case of the experiments. Due to the chosen operation mode (compare chapter 2.4), the sensible mass of the reactor is below the equilibrium temperature. Therefore, any heat losses either to the ambient or to the reactor mass including insulation accelerate the conversion process since the reaction proceeds as soon as heat is released from the reacting material. Therefore, there is no difference for the rate of conversion whether the heat is removed by the HTF or if it is transfer to the sensible masses and to the ambient.

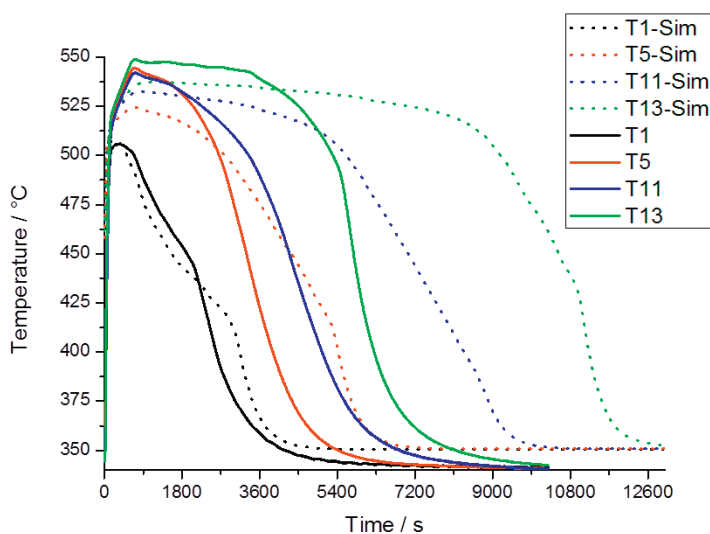

Fig. 7. Comparison of temperature evolutions of the simulation and the experiment

In order to consider these heat losses in the reaction bed, a mathematical term had to be implemented. But, by simply adding a constant value to the model, thermal energy is already released at the starting temperature. Therefore, the heat losses have to be integrated in form of a numerical dependency of the difference between the starting temperature that corresponds to the temperature of the sensible masses around the reaction bed and the current temperature of the material. For this purpose following  $Q_{Loss}$  expression is used:

$$\text{Heat losses in the reaction bed domain} \quad Q_{Loss} = \frac{-\alpha_{Loss} \frac{W}{m^2 K} \cdot (T - T_{start})}{height_{bed}} \quad (2)$$

The constant  $\alpha_{Loss}$  is then adapted to the experimental results. Figure 8 shows the comparison with the included heat loss term. During the period of the highest temperature difference (350 °C to 525 °C), the heat losses accumulate to approximately 2 kW. This corresponds to the experimentally estimated value based on the change of the filling level and the effective power output determined by the temperature difference of the HTF before and after

the reactor. However, since the equilibrium temperature cannot be reached, this generic approach gives valuable information about the processes within the reaction bed for a given operation mode but needs to be optimized in order to account for local effects.

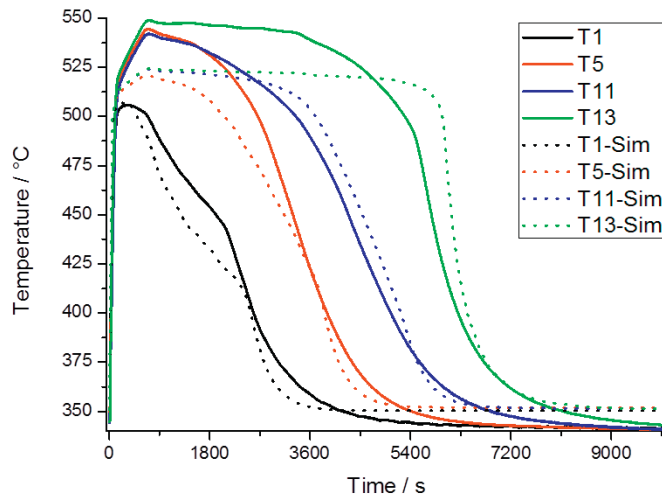

Fig. 8. Comparison of temperature evolutions of the experiment and the simulation with included heat loss term

## 5. Summary and conclusion

Based on experimental results of a 10 kW scale reaction bed for thermochemical heat storage with the reaction material  $\text{Ca}(\text{OH})_2$ , one possible operation mode of thermochemical heat storage has been analyzed. Due to the release of thermal energy by the chemical reaction and a starting temperature that is below the equilibrium temperature of the reaction system, the temperature of the storage increases. Therefore, the temperature increase of the sensible masses of the reactor already consumes chemically stored thermal energy. This effect was analyzed by a developed simulation tool. It was shown that these losses can be estimated by implementing a loss term into the simulation and accounts for around 2 kW during the first minutes of the reaction.

Additionally, the good agreement between the experimental and simulated results show that the reaction kinetics determined in micro-scale measurements as well as the known bed properties offer a sufficient representation of the effective conditions within the bed.

Future work will therefore be concentrated on different operations modes and derived integration strategies for thermochemical heat storage systems, e.g. for CSP plants.

## Acknowledgements

This work has been partially funded by the European Commission under the 7<sup>th</sup> Framework Programme in the frame of the TCS-Power project under contract 282889.

## References

- [1] Schaube, F., Koch, L., Wörner, a., & Müller-Steinhagen, H. (2012). A thermodynamic and kinetic study of the de- and rehydration of  $\text{Ca}(\text{OH})_2$  at high  $\text{H}_2\text{O}$  partial pressures for thermo-chemical heat storage. *Thermochimica Acta*, 538, 9-20, 2012
- [2] Schaube F. et al., De- and rehydration of  $\text{Ca}(\text{OH})_2$  in a reactor with direct heat transfer for thermo-chemical heat storage. Part A: Experimental results. *Chemical Engineering Research and Design*, 2012
- [3] Rosemary J.K., Bauerle G.L., Springer T.H., Solar energy storage using reversible hydration-dehydration of  $\text{CaO-Ca}(\text{OH})_2$ , *Journal of Energy* 3 (6),321-322, 1979
- [4] Matsuda H. et al., Kinetic study of  $\text{Ca}(\text{OH})_2/\text{CaO}$  reversible thermochemical reaction for thermal energy storage by means of chemical reaction, *Kagaku Kogaku Ronbunshu* 11 (5), 542-548, 1985
- [5] Galwey A.K., Laverty G.M., A kinetic and mechanistic study of the dehydroxylation of calcium hydroxide, *Thermochimica Acta* 228, 359-378, 1993
- [6] Schmidt M. et al., Experimental Results of a 10 kW High Temperature Thermochemical Storage Reactor Based on Calcium Hydroxide, *Applied Thermal Engineering*, submitted
- [7] Schmidt M. et al., High Temperature Thermochemical Heat Storage: Experimental Results of a Pilot Reactor Based on  $\text{CaO/ Ca}(\text{OH})_2$ , IRES 2012, Berlin, Germany
- [8] Schaube F. et al., De- and rehydration of  $\text{Ca}(\text{OH})_2$  in a reactor with direct heat transfer for thermo-chemical heat storage. Part B: Validation of model. *Chemical Engineering Research and Design*, 2013