

## PASSIVE DAMPING OF SPACECRAFT SANDWICH PANELS

Romberg, O. (1), Tausche, M. (2), Pereira, C. (3), Panning, L. (4)

(1) Deutsches Zentrum für Luft- und Raumfahrt (DLR), Am Fallturm 1, 28359 Bremen, Germany

(2) OHB-System AG, Universitätsallee 27-29, 28359 Bremen, Germany

(3) RUAG Aerospace, Widenholzstr. 1, 8304 Wallisellen, Switzerland

(4) Institut für Dynamik & Schwingungen, Appelstrasse 11, 30167 Hannover, Germany

Oliver.Romberg@dlr.de

### Abstract

For reusable and expendable launch vehicles as well as for other spacecraft structural vibration loads are safety critical design drivers impacting mass and lifetime. Here, the improvement of reliability and safety, the reduction of mass, the extension of service life, as well as the reduction of cost for manufacturing are desired. Spacecraft structural design in general is a compromise between lightweight design and robustness with regard to dynamic loads. The structural stresses and strains due to displacements caused by dynamic loads can be reduced by mechanical damping based on passive or active measures. Passive damping systems can be relatively simple and yet are capable of suppressing a wide range of mechanical vibrations. Concepts are low priced in development, manufacturing and application as well as maintenance-free. Compared to active damping measures passive elements do not require electronics, control algorithms, power, actuators, sensors as well as complex maintenance. Moreover, a reliable application of active dampers for higher temperatures and short response times (e. g. re-entry environment) is questionable. The physical effect of passive dampers is based on the dissipation of load induced energy. Recent activities performed by OHB have shown the function of a passive friction-damping device for a vertical tail model of the German X-vehicle PHÖNIX but also for general sandwich structures. The present paper shows brand new results from a corresponding ESA-funded activity where passive damping elements are placed between the face sheets of large spacecraft relevant composite sandwich panels to demonstrate dynamic load reduction in vibration experiments on a shaker. Several passive damping measures are investigated and compared.

### INTRODUCTION

Lightweight structures in many kind of spacecraft application are affected by dynamic loads. E. g. the structural dimensioning of components are dominated by the so-called “buffeting loads” which are stochastic aerodynamic pressures occurring in the sub-sonic/supersonic flight phase. Whereas the structures of an expendable launch vehicle are in general loaded only once, structures of a *re-usable launch vehicle* (RLV) are subject to recurring loads, especially during its repeated operation phases for decades of use.

A typical goal for the system operational lifetime of a future RLV is about 30 years. As a consequence, structures and sub-systems are loaded multiple times during the operation cycles. Accumulated over a 30-year life cycle with up to

120 re-uses the structures have to be designed and qualified for millions of load cycles. More details of RLV relevant loads are described in [Rom 01, 03]. It can be stated that for much components and sub-systems the dynamic loads are decisive for spacecraft design. For instance the dynamical requirements for a satellite connected to a launch adapter could drastically relaxed if the dynamical loads are decreased. Here, the reduction of mass, the extension of service life, the improvement of structural reliability and safety as well as the reduction of cost for manufacturing and maintenance are desired.

A promising possibility of dynamic stress reduction is the increase of mechanical damping which can be achieved by passive or active measures, e. g. using piezo-actuators. Latter are complex and require electronics, control technique,

sensitive sensors and actuators as well as maintenance. Moreover, a reliable application of active dampers for higher temperature is questionable.

Suppression of dynamic loading can also be obtained by using a simple, lightweight and reliable method of *friction based passive damping*. Passive friction damping concepts are applied in many areas of mechanical engineering, e. g. damping of turbine blades, leaf springs for trucks, car wheels, brake disks, damping of aerodynamic flutter, earthquake protection, see e. g. [All 86, Chen 89, Pan 05, Sext 98, Sin 83, Sin 85-1, Sin 85-2]. Here, undesired mechanical vibrations are suppressed by dry (coulomb) friction within construction joints. This well known effect is based on energy dissipation and is achieved by the application of friction elements with adjustable normal forces. These lightweight damping elements are made of composites or even of temperature resistant materials, e.g. metal, if required. Thus, they are also applicable for temperatures where viscous damping devices fail. Depending on their application these elements are capable of increasing the damping ratio drastically in case of forced vibrations. The mass increase due to the additional components is almost negligible.

The concept described here has already been applied for the aluminium structure of the German RLV-demonstrator PHÖNIX, see [Rom 03]. In corresponding experiments (shaker tests) performed for an 1:1 scaled tail model the application of passive damping devices based on friction elements results nearly in a duplication of the damping ratio. For those kind of components, where dynamic loads are decisive for the design a reduction of mechanical loading can be directly transposed to mass reduction and life span extension. Structural analyses for the PHÖNIX tail model results in a mass saving potential of ~25%. Since it is reasonable to extend these kind of investigations to basic (spacecraft)-structures, e. g. shells, plates, grids, rods the present paper describes an ESA-funded activity where passive damping elements are placed *between the face sheets of large spacecraft relevant composite sandwich panels*.

With corresponding demonstrators the dynamic load reduction in vibration experiments are investigated.

### PASSIVE DAMPING STATE OF THE ART

A starting point of the activities was a review of available technologies for damping. The technologies were benchmarked against each other based on following parameters:

- Ease of technology transfer to sandwich structures
- Efficiency of damping system
- Suitability for use in space environment

The review yielded several technologies which could be applied to a spacecraft sandwich structure. The following Table 1 presents the technologies which have been investigated in literature together with numbers of frequency and temperature range given there.

**Tab1:** Possible damping technologies

Technology	Frequency range (ROM)	Temp. range
Thermoplastic cores	Up to 4000 Hz	-60°C to 300°C
Electro- and magnetorheological fluids	Up to 50 Hz	-40°C to 150°C
Integral passive damping	Up to 4000 Hz	0°C to 100°C
Multilayer		
Constraint layer		
Magnetic constrained layer damping		
Foam filling		
Sleeves in honeycomb		
Shunted Piezoelectrics	Up to 100 kHz	-10°C to 250°C
Shunted Magnetostrictive	Up to 10 kHz	-50 °C to 100°C
Shape memory alloy	-	-150°C to 200°C
Damping by friction ledge	Unlimited	Unlimited
Damping by preloaded sheet metals		
Friction by particles		
Gas compression		
Particle impact damping		
Tuned mass damping	Up to 250 Hz	0°C to 100°C

Finally, three promising technologies were selected for further investigation. The modified component is either the core in the case of visco-elastic and

frictional damping or the face sheets for shunted piezo-electric systems.

The two core modification technologies were pursued also due to their inherent simplicity. In the following the favorite *friction damping concept* is described in more detail.

### APPLIED DAMPING CONCEPT

For present investigation the reduction of mentioned above dynamical loads is applied by passive elements based on *friction damping*. The corresponding elements, i. e. friction ledges, are laminated into a typical S/C-relevant composite sandwich panel. The damping system consists of four simple components:

- one casing made of wrapped carbon fibre reinforced plastic (CFRP)
- two friction ledges made of CFRP
- one spring to generate the normal force between friction ledges and casing

The functioning is based on relative displacements between the ledges and the casing during panel deformation due to vibrations. The relative displacements cause friction forces and result finally in a vibration suppressing energy dissipation. Fig. 1 shows the principle of applied concept.

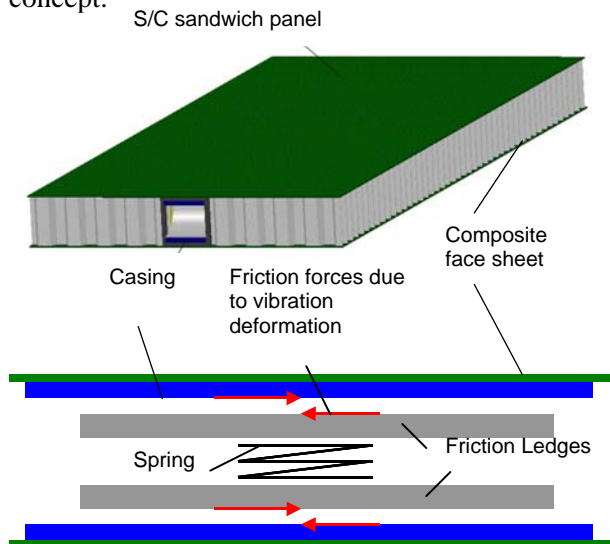

**Fig. 1:** Principle of applied damping concept

The most important parameter of adequate working elements is the optimal contact pressure which depends beside the location upon the geometry, the displacement (vibration mode), the elasticity and

the friction coefficient. The general effects, the theoretical background as well as the application of friction elements are described e. g. in [Popp 90, Hin 96, Good 62, Earl 72, Cam 87] in more detail. An analytical solution is only possible on the basis of simple assumptions. Corresponding numerical solutions require a high calculation effort in order to optimise a friction element. With Finite Element Methods the calculation of non smooth dynamics is not - or just restricted possible with high effort and very time consuming.

The mathematical treatment of non-linear dynamics linked with friction presently is subject of intensive research world wide. For insights into this area, see e. g. [Oes 96, Gura 96, Chen 89].

In the following the damping mechanism for the concept applied here is discussed in more detail.

### DESIGN OF DAMPING ELEMENTS

In order to gain the maximum damping effect, an optimization of the aforementioned friction ledges has to be performed. Since the damping concept is passive in its nature and no active elements are applied to adjust design parameters according to the actual operating conditions, the friction ledges have to be designed very carefully under consideration of the physical and design engineering boundary conditions. Before addressing the optimization in more detail, in the following the necessary steps during the design of friction ledges can be stated in general:

- Determination of the *vibration mode* of interest (natural frequency, mode shape, damping): The knowledge, especially about the mode shape, is essential in order to design the friction ledge adequately.
- Identification of a reasonable *location and shape of the friction ledges*: Depending on the considered mode shape, it has to be decided where to apply discrete or continuous friction dampers.
- Calculation of the *kinematic and elastic relative displacements*: Depending on the kinematic displacements (contacting structures without elastic deformation) and elastic deformations (due to friction forces), the effective relative displacements have to be calculated.

- Determination of the *optimal normal pressure*: As mentioned above, one of the most important parameters is the contact normal pressure. Once, the relative displacements are known, the optimal value leading to the maximum damping effect can be determined, see below.
- Estimation of dissipated energy, *equivalent damping ratio* and vibration amplitudes: To predict the resulting amplitudes, the achieved overall damping by material and friction damping has to be estimated.

Following the proposed five steps, at first, the vibration mode has to be determined which has been done by an explicit Finite Element analysis of the panel, see Fig. 2. The vertical (out of plane) displacement  $w(x)$  along the panel with length  $l$  can be approximated very well by a cosine function,

$$w(x) \approx \frac{1}{2} \hat{w} \left( 1 - \cos \left( 2\pi \frac{x}{l} \right) \right).$$

Since a continuous friction ledge is applied, no particular position along the  $x$ -axis, which may be of interest for a discrete damper, is chosen. The friction ledge is designed as a beam structure with rectangular cross section, see Fig. 1.

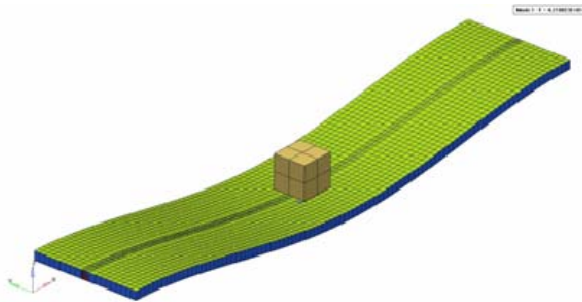

**Fig. 2:** Bending vibration mode of the CFRP panel

The resulting kinematic displacements of both the casing and the friction ledge can be calculated by multiplying the slope  $w'(x)$  and the distance to the neutral axis of the bending mode,

$$u_{\text{casing, kin}}(x) = -\frac{1}{2} w'(x)a = -\frac{\pi}{2L} \hat{w} a \sin \left( 2\pi \frac{x}{l} \right),$$

$$u_{\text{ledge, kin}}(x) = \frac{1}{2} w'(x)b = \frac{\pi}{2L} \hat{w} b \sin \left( 2\pi \frac{x}{l} \right),$$

compare Fig. 3 for details.

Due to the symmetry properties the conclusions are given only for the upper left quarter of the assembly.

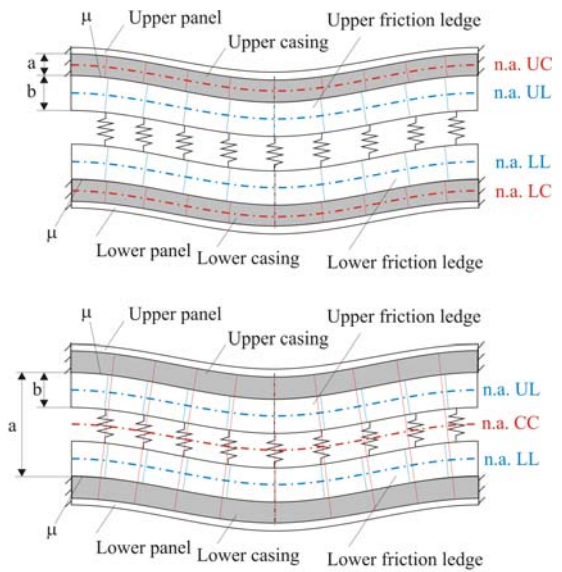

n.a. LC Lower casing neutral axis    n.a. LL Lower ledge neutral axis  
n.a. UC Upper casing neutral axis    n.a. UL Upper ledge neutral axis  
n.a. CC Common casing neutral axis

**Fig. 3:** Bending deformation of the casing and the friction ledges depending on the shear stiffness of the casing

Special attention has to be paid to the question if the upper and lower part of the casing is subjected to bending independently or if the upper and lower part is coupled and performs a bending mode about a common neutral axis. This fact is illustrated in Fig. 3, where the distance between the respective neutral axes and the location of the contact interface is denoted as  $a/2$  for the casing and  $b/2$  for the ledges.

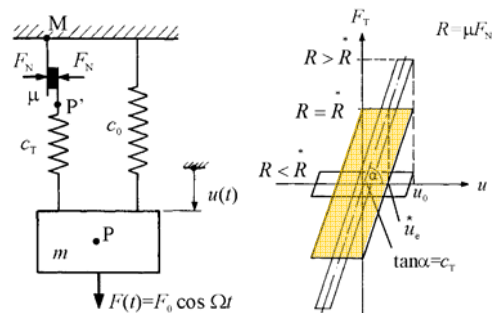

**Fig. 4:** 1-dof system and optimization of the area of the hysteresis loop leading to an optimal normal force

Based on the analysis of a 1-dof system and an optimization of the area of the friction hysteresis loop, see Fig. 4, these results can be transferred to continuous systems like contacting beam-like structures, see e.g. [Wiss 85, Klla 90] and Fig. 5.

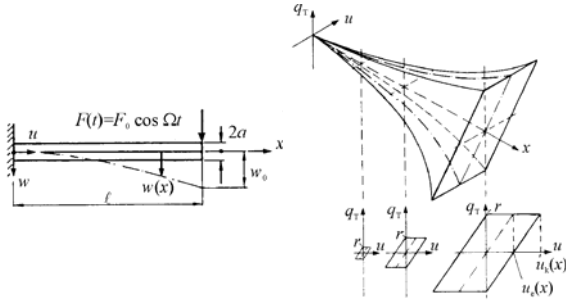

**Fig. 5:** Contacting beams and optimization of the friction hysteresis volume leading to an optimal normal pressure distribution  $p_N(x)$

From the optimization procedure with respect to the normal force acting between beams it becomes obvious that, in general, the optimal normal pressure  $p_N(x)$  is the result of a calculus of variations. However, [Wiss 85] has shown that the achievable damping is almost the same if an optimal *constant* normal pressure  $p_{N,opt} = \text{const}$  is chosen at all values of  $x$  instead that is much easier to apply from a practical point of view. Assuming the boundary conditions

$$u(x=0) = u(x=l) = 0$$

at the fixed ends of the casing and the ledges, the elastic deformations can be determined by

$$u_{\text{casing, el}}(x) = -\frac{1}{2(EA)_{\text{casing}}} \mu q_N (x^2 - lx),$$

$$u_{\text{ledge, el}}(x) = \frac{1}{2(EA)_{\text{ledge}}} \mu q_N (x^2 - lx),$$

with the coefficient of friction  $\mu$ , the distributed normal force (force per unit length)  $q_N$ , the panel length  $l$  and Young's moduli  $E$  and cross section areas  $A$  of the ledges and the casing, respectively. In the case of a common neutral axis for bending, see Fig. 2, the optimal distributed normal force can be determined by

$$q_{N, \text{opt}} = 6\hat{w} \frac{a-b}{\mu^3 \left( \frac{1}{(EA)_{\text{casing}}} + \frac{1}{(EA)_{\text{ledge}}} \right)}$$

from the condition that the energy dissipation is maximised. It becomes obvious that the vibration amplitude  $\hat{w}$  has an impact on the optimal normal force: The larger the vibration amplitude, the larger is the optimal normal force due to the increasing relative displacements. This fact can be also taken from an analysis of a very simple mechanical model given in Fig. 4. Furthermore, these conclusions can be stated:

- For larger longitudinal stiffness  $EA$ , the relative displacements increase since less elastic deformations occur and, corresponding to Fig. 4, the optimal normal pressure increases.
- For the same reason, an increasing difference between the distances  $a$  and  $b$  leads to a higher normal pressure.
- A larger coefficient of friction reduces the optimal normal pressure due to the fact that the contact tends to sticking instead of sliding.

In the case of an independent upper and lower part of the casing, the negative sign in the nominator changes into a positive sign due to the modified relative displacements between the casing and the friction ledges, see Fig. 3. This may illustrate the necessity to consider the vibration mode very accurately due to the large impact of the kinematic relative displacements on the determination of the optimal normal pressure.

#### DEMONSTRATOR DESIGN

The applied friction damping concept is realized by a very simple assembly, see Fig. 6.

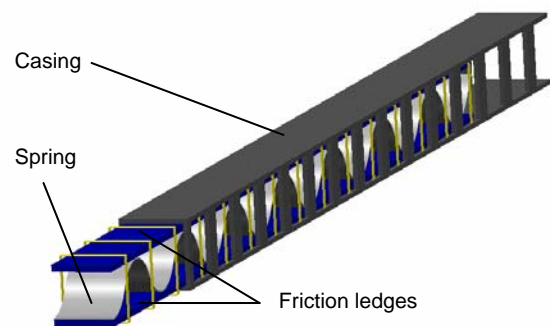

**Fig. 6:** Friction ledge assembly

As mentioned above the assembly consists of three different parts only.

The friction ledges are made of carbon fibre with a very high longitudinal stiffness to guarantee a relative motion between the ledges and the casing during the oscillation of the panel.

The leaf spring is made of spring steel and generates the desired normal force.

The casing is made of CFRP and acts as the counterpart to the friction ledges. This allows embedding a closed and modular friction damper unit into a panel structure with a simple interface, see Fig. 7.

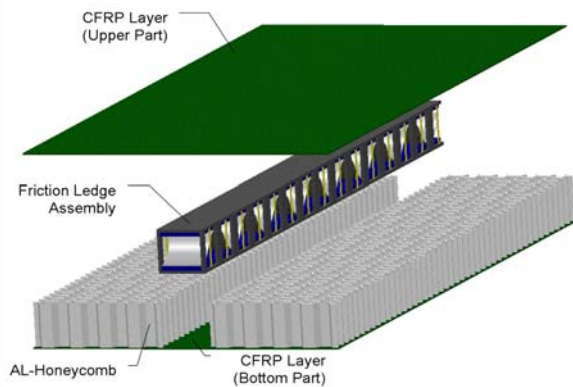

**Fig 7:** Damping assembly within S/W panel

The breadboard design focus on the demonstration of the damping behaviour of spacecraft relevant full scale panels considering available test facilities. In this first step of development a possible curvature geometry of a real S/C panel is neglected. Here, a flat demonstration sandwich panel with the dimensions of 2000 mm length, 400 mm width and 30mm height is selected. To investigate the influences of the damping elements a non damped reference panel and two damped panels will be manufactured. Experimental tests on

- damping behaviour,
- functionality,
- temperature and
- long-term behaviour

will be carried out.

Fig. 8 shows a sketch of the experimental set-up for the shaker. The panel (green) is clamped on both sides on a frame structure, whereas a mass in

the mid of the structure represents e. g. an electronic box and enables flexibility regarding the eigenfrequency of the system.

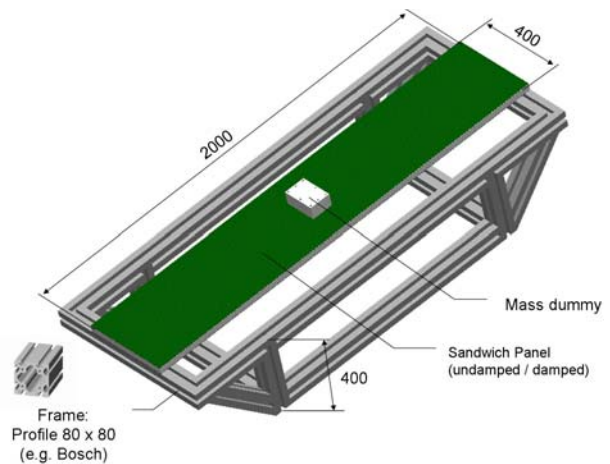

**Fig. 8:** Demonstrator test set-up

#### DEMONSTRATOR MANUFACTURING & TESTS

The following systems will be manufactured and tested:

- one non-damped reference CFRP sandwich panel for comparison
- two damped panels with friction damping system
- two damped panels using visco-elastic damping system

The layout of the panels will be representative of spacecraft design and will consist of two six layer quasi-isotropic CFRP faces using prepregs with an epoxy matrix (fiber content: 58% volume) bonded to a vented aluminium honeycomb core by an epoxy film adhesive. Integration of the panels will be done in a dedicated composite cleanroom at RUAG, Emmen facilities.

During the tests the dynamical behaviour of the dampened panels will be compared with that of the non-dampened reference panel. In addition to the characterization of the sandwich structure the intended testing includes:

1. Flexural test with strain gauges
2. Full level sine load
3. Random vibration test

These tests will be performed at room temperature and at 50°C. One of the dampened panels will be aged either thermally or by subjecting it to high cycle fatigue to evaluate end of life properties.

#### SUMMARY & OUTLOOK

The damping ratio of a structural system has large influence on the structural response and, thus, on the stress. If the damping factor increases the stress decreases drastically, which is necessary for the operation of future reusable launch vehicles as well as to relax dynamical requirements for conventional spacecraft. In the frame of the here described activities a system of passive friction damping elements has been designed which is placed *between the face sheets of large spacecraft relevant composite sandwich panels*. Presently, corresponding demonstrators are in manufacturing process. Dynamical and thermal test will be performed in near future. In parallel investigations regarding the mass saving potential as well as the life span extension due to increased damping are performed. The influence on the life span will be clarified by means of S-N-curves [MIL 5H], where the critical stress (crack) is depicted versus the load cycles (= life span in case of continuous vibrating structures). Depending upon the material as well as upon the structure there are empirical results showing a decreasing boundary stress with increasing number of load cycles. Instead of steel which shows a horizontal tangent of critical stress for load cycles composite materials have a *steady decreasing S-N-curve*. Thus, the life span of those materials are directly affected by the number of load cycles in combination with the vibration amplitude. The degree of life span extension depends strongly upon the material, the structure and the load cases and can be quantified for individual cases only. In any case the impact of long term application, wear and temperature impact have to be considered, too.

#### ACKNOWLEDGEMENT

The work is fully funded by the European Space Agency (ESA) in the frame of the General Space Technology Programme (GSTP).

#### REFERENCES

- [Kla 90] Klamt, K.: *Zur optimalen Schwingungsdämpfung durch Fügestellenreibung in Strukturen*, Fortschrittsbericht, VDI Reihe 11, Nr. 134, Düsseldorf 1990
- [All 86] Allen, J. M.: *Friction Damping in Compressor Blade Dovetail Attachments*. ASME paper 86-GT-137, 1986
- [Astra 01] ASTRA System Concepts Studies: *Concept I - Sub-orbital Hopper Summary Description*, Draft, June, 2001
- [Cam 87] Cameron, T. M.; Griffin, J. H.; Kielb, R. E.; Hoosac, T. M.: *An Integrated Approach for Friction Damping Design*. ASME Bound Volume DE-5, 1987, pp. 205-212
- [Chen 89] Chen, S.; Sinha, A.: *Probabilistic Method to Compute the Optimal Slip Load for a Mistuned Bladed Disk Assembly with Friction Dampers*. ASME Bound Volume DE-18.3, 1989
- [Earl 72] Earles, S. W. E.; Williams, E. J.: *A Linearized Analysis for Frictionally Damped Systems*. Journal of Sound and Vibration, Vol 24 (1972), No. 4, pp. 445-458
- [Good 62] Goodman, L. E.; Brown, G. E.: *Energy Dissipation in Contact Friction: Constant Normal and Cyclic Tangential Loading*. In: Trans. ASME, Journal of applied Mechanics 29 (1962), pp. 17-22
- [Gura 96] Guran, A.; Pfeiffer, F.; Popp, K. (Eds.): *Dynamics with Friction - Modelling, Analysis and Experiment -World Scientific Publishing Singapore. Part I, 1996; Part II, 2000*
- [Hin 96] Hinrichs, N.; Oestreich, M.; Popp, K.: *Coexisting Periodic Solutions for a Non-Smooth Friction Oscillator*. ZAMM, 76, 1996
- [Hin 98] Hinrichs, N.; Oestreich, M.; Popp, K.: *On the Modelling of Friction Oscillators*. Journal of Sound and Vibration, 216, 1998
- [Rom 01] Romberg, O.; Janovsky, R.; Wienss, W.: *Mechanical Damping for Future RLV-Structures*, 3<sup>rd</sup> European Conference on Launcher Technology, Strassbourg, 2001
- [Oes 96] Oestreich, M.; Hinrichs, N.; Popp, K.: *Bifurcation and Stability Analysis for a Non-Smooth Friction Oscillator*. Archive of Applied Mechanics, 66, 1996
- [Popp 90] Popp, K.; Stelter, P.: *Stick-Slip Vibrations and Chaos*. Phil. Trans. R. Soc. Lond. A, 332, 1990

- [Sext 96] Sextro, W.; Popp, K.: *Dynamical Behaviour of a Bladed Disk with Friction Dampers*. Proc. of EUROMECH-2<sup>nd</sup> European Nonlinear Oscillation Conference, Vol. 1, Prag, 1996, pp. 391-394
- [Sext 98] Sextro, W.; Popp, K.; Wolter, I.: *Three-Dimensional Vibration of Bladed Disk Assemblies with Friction Dampers*. Proc. ISROMAC-7, Vol. B, Honolulu, Hawaii, 1998
- [Sin 83] Sinha, A; Griffin, J. H.: *Friction Damping of Flutter in Gas Turbine Engine Airfoils*. Journal of Aircraft 20 (1983), No. 4, pp. 372-376
- [Sin 85-1] Sinha, A; Griffin, J. H.: *Stability of Limit Cycles in Frictionally Damped and Aerodynamically Unstable Rotor Stages*. Journal of Sound and Vibration 103 (1985), No. 3, pp. 341-356
- [Sin 85-2] Sinha, A; Griffin, J. H.: *Influence on Friction Dampers on Torsional Flutter*. ASME Paper 85-GT-170 (1985)
- [Spies 01] Spies, J.: *ASTRA System Requirements, Design Standards and Technology Assumptions*, Draft, 2001
- [Stel 90] Stelter, P: *Nichtlineare Schwingungen reibungserregter Strukturen*, Fortschrittsbericht, VDI Reihe 11, Nr. 137, Düsseldorf 1990
- [Trey 95] Treyde, T: *Modellierung des Kontaktes zwischen den Deckplatten von Turbinenschaufeln*, Fortschrittsbericht, VDI Reihe 11, Nr. 224, Düsseldorf 1995
- [Rom 02] Romberg, O.: *ASTRA AP 4000: Strukturen, Bauweisen & Materialien, AP 4220: Passive Schwingungsdämpfung*, Schlußbericht [ASTRA-OHB-4220-SB], Oktober 2003
- [MIL 5H] Military Handbook (5H), *Metallic Materials & Elements for Aerospace Vehicle Structures*, 1998
- [Kro 03] Kröger, M. Reckmann, H. Popp, K. Romberg, O.: *Reibleistendämpfung in Leichtbaustrukturen*, GAMM, 2003
- [Rom 03] Romberg, O.; Tausche, M.; Kröger, M.: *Passive Damping of a Vertical Tail*, 54th International Astronautical Congress IAC 2003, Bremen, October 2003
- [Pan 05] Panning, L.: *Auslegung von Reibelementen zur Schwingungsdämpfung von Turbinenschaufeln*. VDI-Fortschrittberichte, Reihe 11, Nr. 328, VDI-Verlag Düsseldorf, 2005