

GNSS Receiver Testing by Use of a Hardware Signal Simulator with Emphasis on Pulsed and CW Interference

Holmer Denks, Achim Hornbostel,
German Aerospace Center (DLR)

Vincent Chopard, *Thales Avionics*

ABSTRACT

In aviation environments various interference sources exist, which can degrade the performance of on-board receivers as well as the performance of ground based reference receivers (e.g. in GBAS stations). Therefore, besides functional receiver validation under nominal conditions also the behavior of the receiver under strong interference conditions, namely CW interferers, broadband noise and pulsed interference from Distance Measurement Equipment (DME), must be tested. DME is one of the main interference sources in the E5 Galileo band in aviation environments.

Currently, in the project "ANASTASIA", which is financed by the Sixth Framework Program of the EU, the development of an L1/E5 Galileo receiver for safety-of-life (SoL) applications takes place. Prior to final flight trials this receiver was tested and validated with the help of hardware signal generators. This paper will present an overview of the receiver interference tests. In particular the DME test was performed following the test procedure defined in the Galileo MOPS [4] by EUROCAE WG 62. The test setup will be described in detail and test results will be presented.

INTRODUCTION

Future GNSS like Galileo and the modernized GPS will enable the introduction of satellite navigation into new application areas, where conventional GPS cannot be used. These are in particular safety of life applications, e. g. landing approaches of higher categories in aviation. The new signals provided by future GNSSs require the development of advanced receiver technologies, which make full use of the performance provided by the new signal characteristics. Highly specialized receivers will be developed for specific applications, e.g. for aviation, which must fulfill all requirements defined by the responsible authorities and certification bodies. These receivers need thoroughly testing under controlled and repeatable conditions.

In aviation environments various potential interference sources exist, which can degrade the performance of on-board receivers as well as the performance of ground based reference receivers which are part of a ground based augmentation system (GBAS). Therefore, besides functional receiver validation under nominal conditions also the behavior of the receiver under strong interference conditions, namely CW interferers, broadband noise as well as pulsed interference from Distance Measurement Equipment (DME) must be tested. DME is one of the main interference sources in the E5 Galileo band in aviation environments. Software and hardware simulations have shown already that DME interference can reduce the C/N0 of a receiver by some dB even if pulse blanking is applied in the receiver [1], [2].

Currently, in the project "ANASTASIA", which is financed by the Sixth Framework Program of the EU, the development of an L1/E5 Galileo receiver for safety-of-life (SoL) applications takes place. Prior to the final flight trials in December 2009 at the end of the project, this receiver was tested and validated with the help of hardware signal generators. For this purpose the very powerful Multi-output Advanced Signal Test Environment for Receivers (MASTER) [2], [3], of the German Aerospace Center (DLR) has been utilized. MASTER provides simulated Galileo and GPS signals at the nominal RF carrier frequencies and power levels, which are fed into the antenna port of the receiver under test. The simulator output signal contains the sum of the signals from all or some selected satellites in view for an user-defined receiver position or track. It is possible to generate up to four different carriers simultaneously, e.g. GPS L1 and L2 together with Galileo L1 and E5. All "true data", i.e. the positions of SVs and receivers, pseudo-ranges, errors and so on provided by the simulator, are logged and therefore available for the analysis later on. The simulated signals can embody all kinds of errors present in real satellite navigation signals like orbit perturbations, clock errors, ionospheric and tropospheric errors as well as multipath and interference. A great advantage of receiver testing with simulated signals is that all included errors are exactly

known and can be individually switched on and off. This feature enables the analysis of the contribution of each specific error component on the total performance of the receiver.

This paper provides an overview of the receiver interference tests conducted in order to verify the performance of the receiver developed within the ANASTASIA project. In particular the DME test was carried out following the test procedure as defined in the Galileo MOPS [4] by EUROCAE WG 62. Thus, this test also gives the first practical experiences with this part of the Galileo MOPS test procedures. Following this test procedure, the DME interference is generated in baseband as a MATLAB file according to DME/TACAN characteristics visible from an aircraft flying at 40000 feet over the European hot-spot, which are provided in the Galileo MOPS [4], and then up-converted to RF with help of an AGILENT programmable signal generator. The test scenario is roughly compared to new real measurements of the interference conditions. The test setup will be described in detail and test results will be presented.

ANASTASIA PROJECT

ANASTASIA (Airborne New and Advanced Satellite techniques and Technologies in A System Integrated Approach) is an integrated project which receives funding from the European Community's Sixth Framework Programme (DG research); see www.anastasia-fp6.org. The core of ANASTASIA research is to provide on-board Communication, Navigation and Surveillance (CNS) solutions to cope with the expected increase in air traffic by 2020. We focus in this paper on ANASTASIA sub project (SP) 3 called Navigation and SP5 which deals with operational tests. Within SP3 a receiver mock-up is designed for three Galileo bands (L1, E5a, E5b), which is compliant to the MOPS current standards. SP5 is going to test this receiver up to its limits regarding interferences, multi-paths and low level signals.

GALILEO SIGNALS FOR SOL/OS

The receiver build in the ANASTASIA project is capable to receive Galileo L1 and E5a or E5b signals, which are all included in the allocated spectrum for Aeronautical Radio Navigation Services (ARNS). The signal characteristics are summarized in Table 1.

Table 1 Galileo signal specifications [6]

	L1	E5a	E5b
Service	OS, SoL, CS	OS	OS, SoL, CS
Carrier frequency [MHz]	1575.42	1176.45	1207.14

Receiver Reference Bandwidth [MHz]	24.552	20.46	20.46
Chiprate [Mchips/s]	1.023	10.23	10.23
Modulation	BOC(1,1) (CBOC(6, 1,1/11))	BPSK(10) (AltBOC)	BPSK(10) (AltBOC)
Components	B: Data C: Pilot	I: Data Q: Pilot	I: Data Q: Pilot
Tied Codelengths [ms]	B: 4 C: 100	I: 20 Q: 100	I: 4 Q: 100
Primary Code length [Chips]	4092	10230	10230
Secondary Codelength [Chips]	B: N/A C: 25	I: 20 Q: 100	I: 4 Q: 100
Symbol Rate on data component [symbols/s]	250	50	250

In the current version of the Galileo ICD [5] a signal called CBOC is defined for L1, which is a composite of two binary offset carrier (BOC) signals, where two subcarriers with subcarrier rates of 1.023 and 6.138 MHz are used. The two BOC signals are combined in a way that the power applied to the higher frequency component equals 1/11 of the total power of the resulting CBOC(6,1,1/11) signal. However, both in the ANASTASIA receiver and in the MASTER hardware simulator only a BOC(1,1) signal is implemented. The Galileo E5 signal is generated with ALTBOC-modulation. In the ANASTASIA mock-up receiver E5a and E5b are processed independently and, therefore, behave like two BPSK signals.

E5a overlaps with GPS L5. However, the Galileo Safety-of-Life (SoL) Service is only available on L1 and E5b, while E5a is allocated for Open Service (OS) only. L1 and E5b include also Commercial Services (CS). The selection of E5 frequency bands, in particular for combined GPS/Galileo receivers, is still under discussion in the aviation community. Therefore, the ANASTASIA receiver is able to receive besides L1 both, E5a and E5b signals. The receiver's bandwidths are 8 MHz for L1, 20 MHz for E5a and 14 Mhz for E5b.

CONSIDERED INTERFERERS

Safety of Life main requirements for Avionics. The Eurocae (EUROpean Organisation for Civil Aviation Equipment) manages several working groups which primary task is to prepare performance specifications that may be adopted as standards by the civil aviation industry. These standards are Minimum Operational Performance Specifications (MOPS) or Minimum

Aviation System Performance Specifications (MASPS). The working group 62 is currently working on MOPS for Galileo positioning receivers to ensure that aircraft equipment certified will be compatible with the Galileo signal-in-space specified in ICAO Standards and Recommended Practices. The document defines the radio frequency environment that the receiver will encounter during its operation. Interference masks were defined for L1 (no modification compared to GPS) and E5. Note, that for E5a and E5b different filters are applied for out of band interference rejection, i.e. the effective receiver bandwidth for E5a is 20 MHz, but for E5b it is only 14 MHz, which is smaller than the reference bandwidth indicated in Table 1. The receiver mock-up was used to discuss the E5 requirements and to demonstrate that they were technically sustainable. The main technical requirements were the following ones:

- Spectral separation from MOPS : Maximum out of band Carrier Wave Interferences (CWI), see Figure 1
- Interference mitigation and pulse blanking
- Pseudo-range, pseudo-phase measurements and code/carrier smoothing, data decoding
- GNSS signal acquisition and tracking (GALILEO L1/E5b SoL or L1/E5a)
- Frame synchronization, de-interleaving,
- FEC decoding and CRC checking.

Let's take the maximum out of band RFI levels as an example:

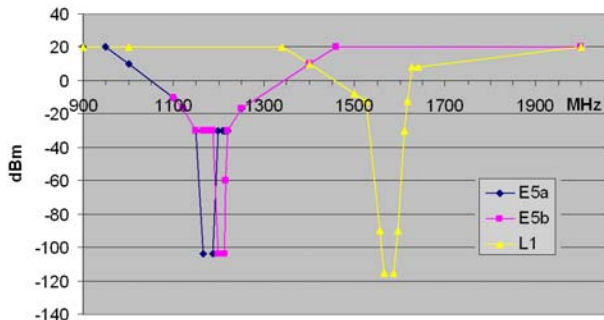

Figure 1: MOPS max. out of band RFI levels for CW

Figure 1 means that the receiver must provide minimum performances in case of a CW interference which power stays below the three different templates corresponding to the three available bands L1, E5a and E5b. For instance, in case of E5b tracking, a CW may be present at a passive antenna output between 900MHz and 2GHz and with a power level below the pink curve and should not be disturbing E5b tracking. It should be understood that when the CWI is located at -30dBm in the E5a band, this band can't be tracked by the receiver. The same occurs with a +20dBm CWI in the L1 band. But in both cases the E5b signal continues to provide its minimum performances. The same example can be followed for E5a or L1 tracking.

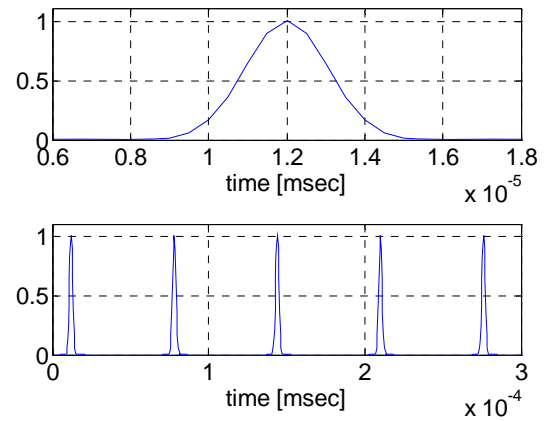

Figure 2: Normalized DME like pulse (time domain)

Pulse blanking:

The first interference test signal which was used to test the receiver behavior (not included in MOPS [4]) is a **simple rectangular pulse**, i.e. a carrier with a frequency inside the band under investigation which is switched on for a time period of $T = 3.5\mu s$ and then switched off again. The pulse is repeated with a rate of $1/T_p = 15000$ pulse per second (for comparison: pulse repetition rate of DME is 2700 pps and for TACAN 3600 pps).

Besides the simple rectangular pulse also a **DME like pulse** is used (compare Figure 2 and Figure 3). Note DME consists of a pulse pair which is not considered here.

Both kinds of pulses are generated within the E5a and E5b bands and with a power of -60 dBm and of -70 dBm.

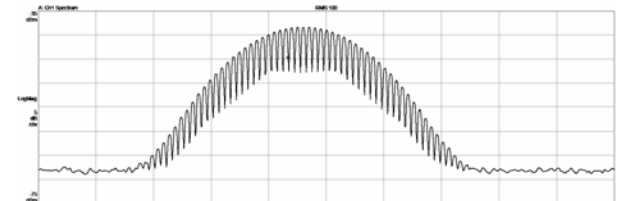

Figure 3: DME like pulse (frequency domain)

Finally a **modelled DME scenario** consisting of a couple of DME/TACAN pulses of different frequency and power is used as a first approximation for realistic interference environments in the E5 band. This scenario is constructed from the DME test scenario described in the EUROCAE GALILEO MOPS [4], which also provides a table with the main characteristics of the DME/TACAN ground beacons signals which are in line-of-sight visibility from an aircraft flying at 40000 feet over the European hot-spot.

These DMEs are modelled as I&Q baseband samples in a MATLAB file and then downloaded to a vector signal generator (Agilent's E8267D). The signal generator modulates the signal on a carrier (1188 MHz) with a given power. For power calibration purpose there is a calibration pulse included at the beginning of the sequence. The total bandwidth of the test signal is 57

MHz (1156MHz to 1213MHz) and the duration is 10 milliseconds. The signal generator repeats the sequence perpetually. Figure 4 and Figure 5 show the test signal in time domain resp. frequency domain.

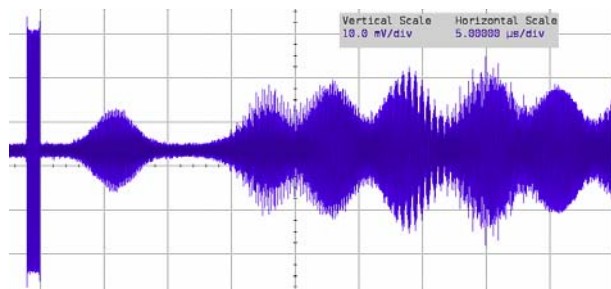

Figure 4: DMEs from MOPS with calibration pulse at the left.

Note the signal shown in Figure 4 is amplified by 40 dB to enable the scope to operate properly and to enable a comparison with the real data shown in the following. On the left hand side the calibration pulse is visible followed by the first DME pulses.

The spectral view of the same signal including the 40 dB gain is shown in Figure 5. In this figure the calibration pulse is no longer noticeable.

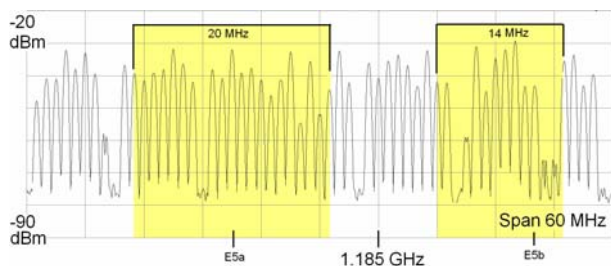

Figure 5: DMEs from MOPS in frequency domain

Within the project ANASTASIA there was a measurement campaign in March 2009 to obtain better and realistic data for the interference scenario at the E5 band. For this purpose flights in different heights were made and data were recorded with a skyward looking Galileo Navigation Antenna.

Figure 6 shows a spectral view (averaged by “max hold”) of a couple of ms of the interference scenario above Frankfurt/Main in Germany which is assumed to be the European Hotspot in respect to DME/TACAN power. The data has been recorded in March 2009 at flight level (FL) 390 which is typical for trans-atlantic flights. Note the data used for the figure are raw data and not yet corrected for the LNA and front-end characteristics. Especially the amplification which is in the order of 40 dB has to be considered. Also the antenna characteristics (pattern as well as gain) are not corrected. The used antenna was a navigation antenna developed within ANASTASIA which was mounted on top of the test aircraft as it is typical for navigation antennas. However, most of the interferers are radiating

from the ground. As can be seen easily the modeled scenario (compare Figure 5) is quite similar. (Remember, that in both figures the signals are amplified by about 40 dB.)

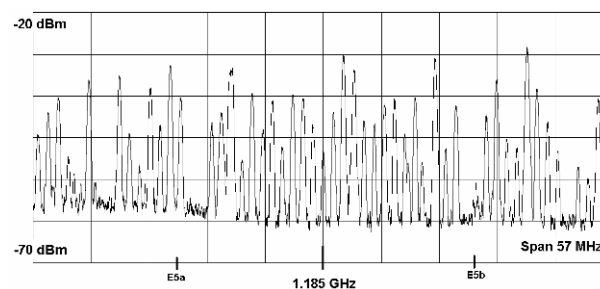

Figure 6: Spectrum recorded at FL390 in March 2009 near Frankfurt/Main.

RECEIVER AND MITIGATION TECHNIQS

Receiver RF architecture: The SoL requirements added to some technological filtering issues lead to the following over-all receiver architecture guidelines (compare Figure 7):

- For the antenna preamplifier (not yet integrated into the passive antenna element), we must separate the amplification in two bands : the whole E5 is separated from L1
- For the receiver itself, a complete three bands separation must be provided to ensure that E5x can be tracked when E5y is perturbed by a -30dBm CWI
- To decrease the frequency plan and receiver complexity, if RF filters can be designed, a single intermediate frequency (IF) is preferred (compared to a double IF scheme with high IF filtering rejection).

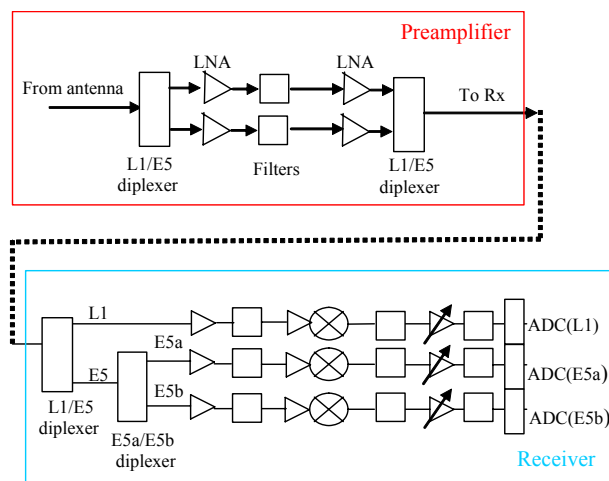

Figure 7: Preamplifier and receiver RF architecture

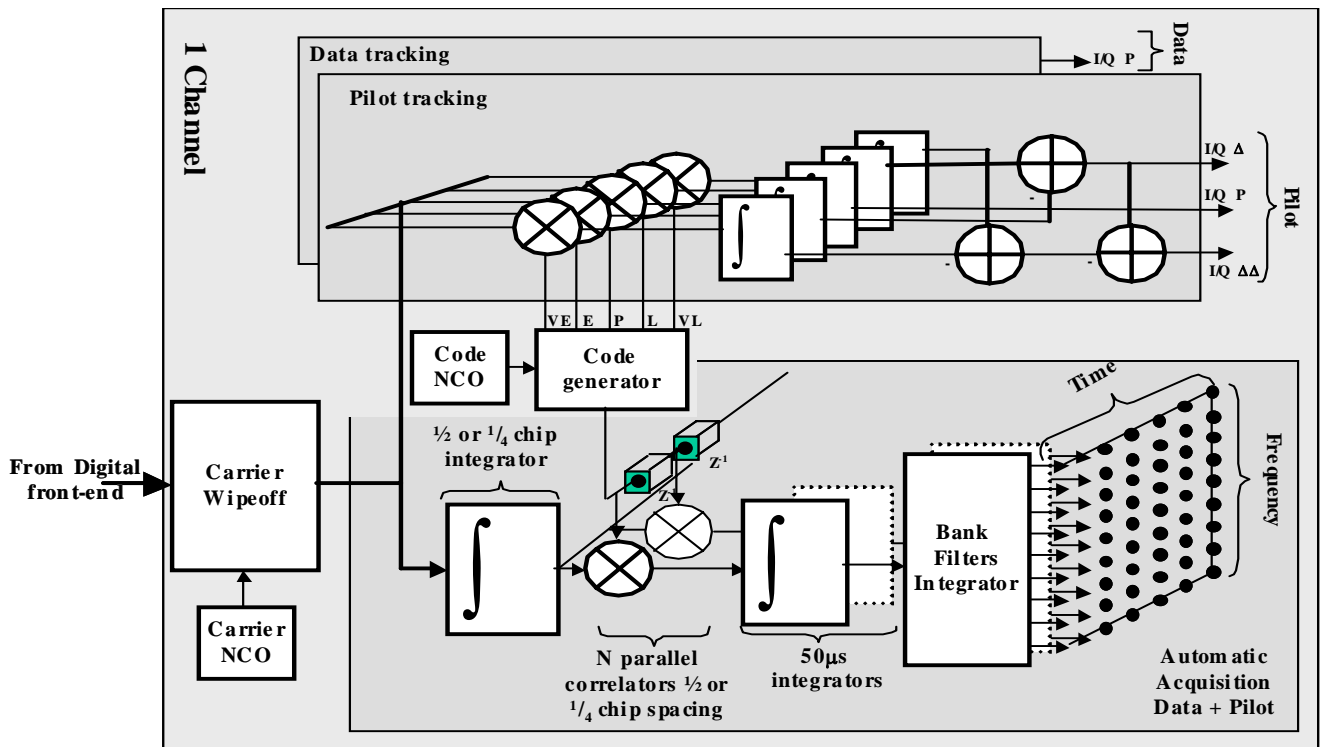

Figure 8: Sample of tracking channel (I-Channel)

Architecture of digital receiver part: The digital architecture can be separated in a digital front end and a set of 30 identical channels for acquisition and tracking as shown in Figure 8 and Figure 9.

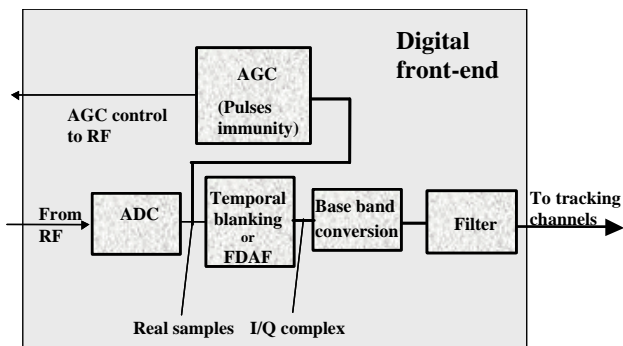

Figure 9: Architecture of digital frontend

Regarding the interference mitigation techniques (IMT) for DME pulses, two of them have been implemented as described in [6]:

The temporal blanking, (with block diagram given in Figure 10) replaces signal samples by zero when the input power exceeds a given threshold.

The FDAF (Frequency Domain Adaptive Filtering) technique (with block diagram given in Figure 11) computes a Fourier transform of the incoming signal on a predefined number of samples (R), by operating a Fast Fourier Transform (FFT) with a variable number of bins (64, 128, 256 or 512 bins). Each bin's energy is compared to a given threshold and suppressed if it exceeds it. All the bins are then converted back in time samples by an IFFT algorithm. The technique intervenes

in the same place as the temporal blanker; the input of the algorithm is therefore a quantized and sampled signal.

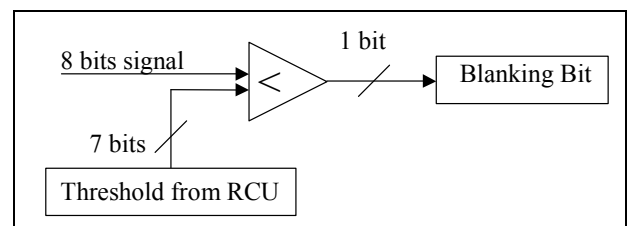

Figure 10: Temporal blanker principle

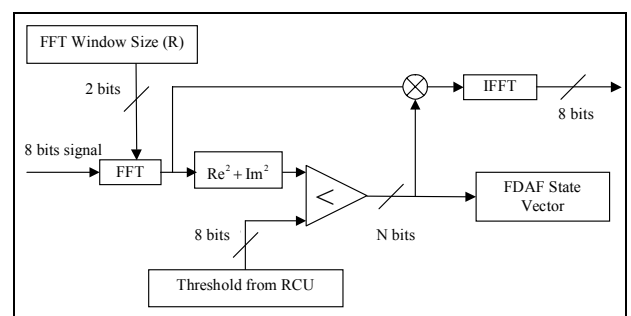

Figure 11: FDAF blanker principle

Note that since the incoming signal is, without disturbances, dominated by thermal noise, the FFT representation of the incoming signal should ideally be flat (white). This assumption allows the determination of a threshold that would represent the usual noise level, with a certain false alarm rate. If any points of the incoming signal's Fourier transform exceed this threshold, they are considered being corrupted by an

interferer and set to zero. Finally, the inverse FFT of the manipulated incoming signal is performed to obtain the signal back in the time domain to enable feeding the acquisition/tracking modules.

The AGC (Automatic Gain Control) has been modified to be insensitive to the presence of DME pulses. The quantized signal is used to estimate the gain to apply at AGC level. In the present study, the loop error voltage is implemented as follows:

$$\varepsilon = 2 \cdot N_0 - N_1 - N_{-1} \text{ (see Figure 12)}$$

Where:

- N_0 is a variable incremented each time a zero comes out the ADC
- N_1 is a variable incremented each time a one comes out the ADC
- N_{-1} is a variable incremented each time a minus one comes out the ADC

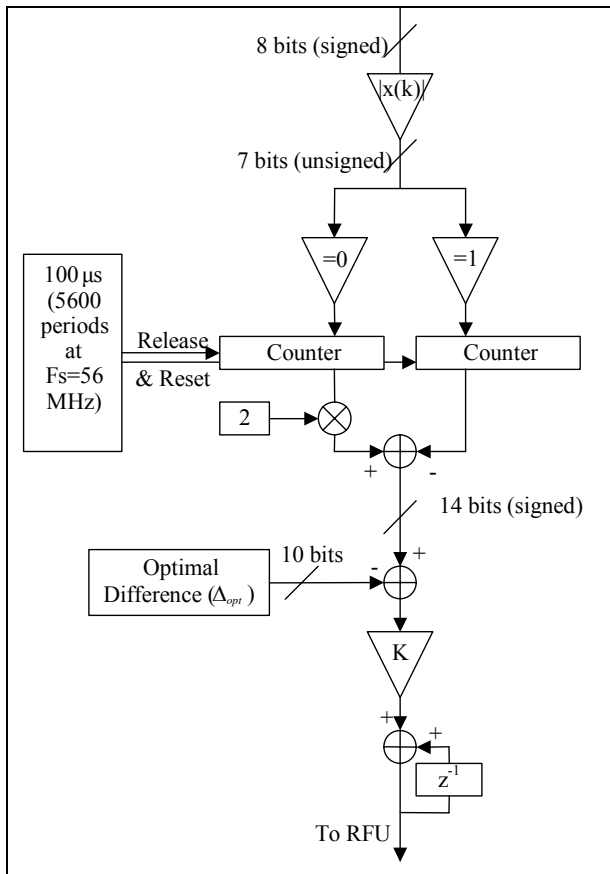

Figure 12: AGC regulation principle

This estimator is based on the ADC output signal distribution. If the output signal is supposed to be Gaussian, the estimator's values depend only upon the ADC quantization levels and signal variance. The estimator is therefore a function of the variance, which is a function of the gain. A block diagram of the ADC is given in Figure 12.

SIMULATION HARDWARWE SETUP

The general simulation setup consists of the MASTER system including the signal generator boxes connected to the receiver under test. Additionally a vector signal generator for the pulse generation and a simple CW generator for the CW interferer are used. A schematic overview of the system is given by Figure 13.

The core of MASTER consists of two modified GSS7790 multi-output full constellation simulators built by Spirent Communications Ltd. which provide besides GPS all Galileo (E1, E5, E6) satellite signals as digital baseband signals. The reason to use two modified GSS7790 is two folded: First it simply doubles the number of channels available. Second, it enables the simulator to produce a mixed GNSS system consisting of GPS and Galileo.

MASTER is controlled by Spirent's SimGEN™ SW running on a control PC. SimGEN™ enables the user to define a simulation environment including parameters such as orbit parameters of the GNSS used, clock errors, iono- and tropospheric effects, antenna pattern, multipath and user trajectories. It is also used to define the satellite in view (SV) signal and its components as navigation data, pilot/data channel and modulation scheme according to the desired frequency band.

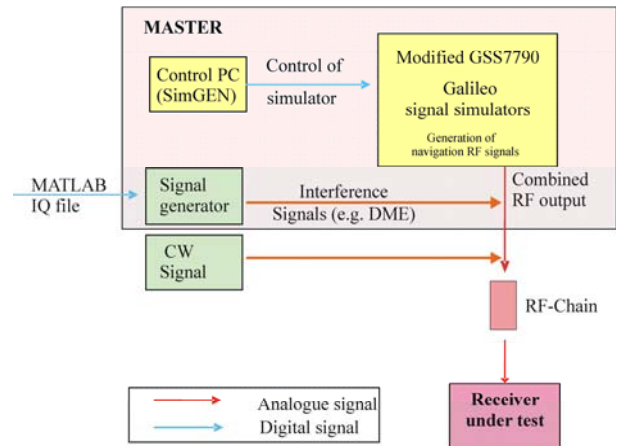

Figure 13: Schematic overview of test setup.

All signals are provided on one combined RF output: To do so the baseband signals generated by the modified GS7790 are combined then D/A converted and mixed to a common IF for all GPS and Galileo frequency bands. At last the combined signal is modulated on the appropriate carrier before a final filtering. The output signal is available on the combined output at a nominal power level of about -130 dBm with a dynamic range of ±20 dB. The combined signal can be directly fed into the RF input port of a single antenna GNSS receiver.

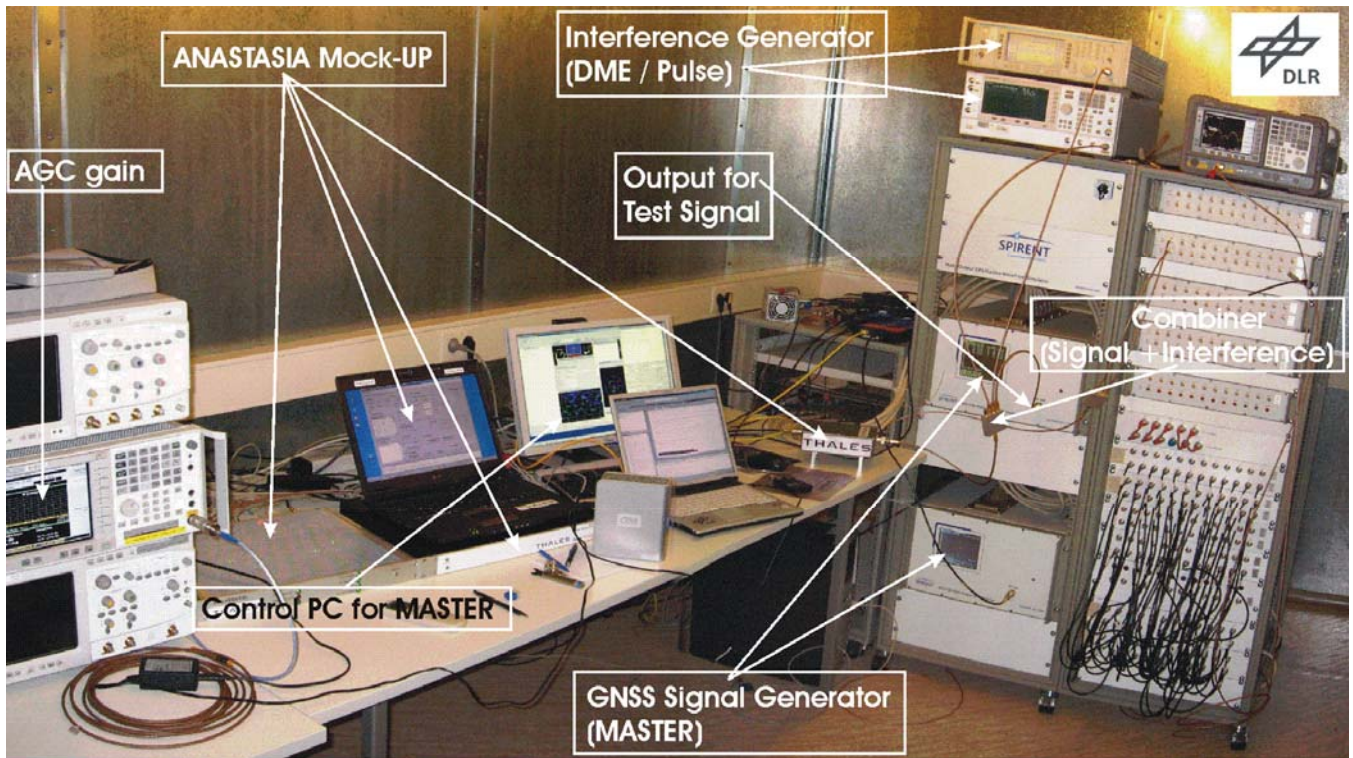

Figure 14: Photo of test setup.

An important feature of MASTER is to provide GNSS signals overlaid with other signals, i.e. interferers, in the same frequency range. There are two different ways of providing the user with interfering signals. The first way is to generate these signals within the modified GSS7790 simulator boxes. The drawback of this method is the limited maximal power and dynamic of the signals at the RF output. Besides this, also the types of interferers are limited to CW and broadband interferers. Therefore, to overcome these limitations, a powerful programmable signal generator (Agilent E8267D) is used instead. With this signal generator, signals can be generated almost arbitrarily.

SIMULATION RESULTS

The GNSS scenario used consists of a full Galileo constellation with L1 and E5 signals. The RTCA98 model was used for troposphere errors and the Klobuchar model was used for the ionosphere errors. The Galileo signals from all SV are set individually to a fixed power level of -122dBm at the preamplifier input. This assumes a nominal GNSS power of -125 dBm [5] and an antenna gain of 3 dBi. No further errors were considered, i.e. for example the clock errors were set to zero. The noise figure of the simulator were checked and found to be 4 dB.

Simulation results with the receiver in Thales premises (before being sent to DLR) are given in Table 2. The tests have been conducted with the MOPS file for DME generation on E5b only.

Table 2: Results for different IMT (measured by Thales)

IMT	No Interference	Hot Spot E5b	Difference
None	40 dB-Hz	22.5 dB-Hz	17.5 dB
Temporal Blanking	40 dB-Hz	28.5 dB-Hz	11.5 dB
FDAF 64	40 dB-Hz	34.5 dB-Hz	5.5 dB
FDAF 128	40 dB-Hz	33.6 dB-Hz	6.5 dB

Table 3: Results for different IMT (measured by DLR)

IMT	No Interference	Hot Spot E5b	Difference
None	40.0 dB-Hz	21.7 dB-Hz	18.3 dB
Temporal Blanking	40.0 dB-Hz	27.2 dB-Hz	12.8 dB
FDAF 64	40.0 dB-Hz	34.3 dB-Hz	5.7 dB
FDAF 128	40.0 dB-Hz	33.2 dB-Hz	6.8 dB

At DLR premise the measurements for E5b were repeated (compare Table 3) and supplemented by measurements for E5a (compare Table 4). The results

for both measurements in E5b are similar. Small differences can be due to uncertainties in the determination of cable losses and adapters and the general measurement accuracy.

Table 4: Results for different IMT (measured by DLR)

IMT	No Interference	Hot Spot E5a	Difference
None	41.7 dB-Hz	< 18.3 dB-Hz	> 23.4 dB
Temporal Blanking	41.7 dB-Hz	24.2 dB-Hz	17.5 dB
FDAF 64	41.7 dB-Hz	33.2 dB-Hz	8.5 dB
FDAF 128	41.7 dB-Hz	32.4 dB-Hz	9.3 dB

Note the C/N_0 value for no IMT in Table 4 could be only estimated because the receiver loses lock. The results for E5a are slightly worse than for E5b. This can be explained by the broader filter bandwidth of the receiver in E5a. For E5b 14 MHz are used and for E5a 20 MHz, but the main part of the energy is located in the band center whereas the interferer are more or less homogeneous spread within the E5 band. In case of a broader bandwidth this results in more interfering energy but almost the same useful signal energy which leads to the worse C/N_0 .

In the FDAF implementation it seems that a higher number of frequency bins has no advantage. This behavior is only due to implementation issues.

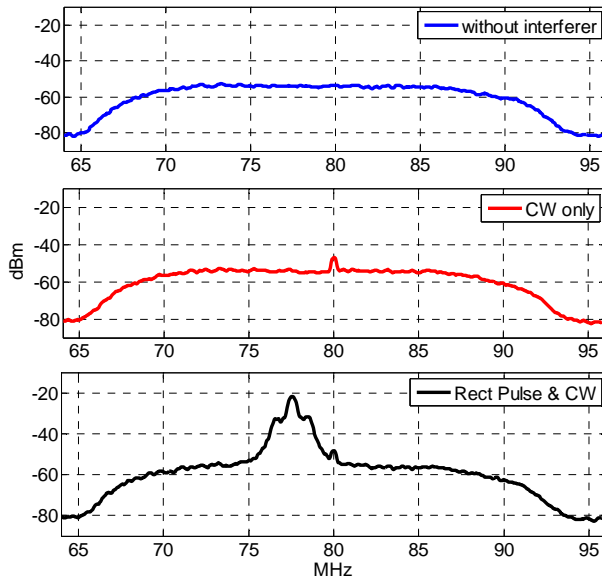

Figure 15: Spectral view of IF after AGC for E5a with different interference scenarios

To demonstrate the proper function of the AGC in situations with strong interference the power level of the IF (approximately 80 MHz) is measured after the AGC.

For this purpose a single quite weak CW of -110 dBm is generated and the power is determined at IF level. This level is compared to the situation with pulsed interference. In Figure 15 the situation is shown for E5a and temporal blanking: The reference CW is generated at 1175 MHz with -110 dBm. At IF level the power measured is -48.4 dBm (compare Table 5). This power level changes only very slightly in the situation with strong interference: The power at IF level is -48.8 dBm for rectangular pulses with a power of -70 dBm and 49.8 dBm for those with -60 dBm.

Table 5: Results temporal blanking with rectangular pulses

Band	CW frequ. [GHz]	Pulse input power	Pulse frequ. [GHz]	Meas. power [dBm]	Blanking rate
E5a	1.175	off	off	- 48.4	0 %
E5a	1.175	-70 dBm	1.1775	- 48.8	6 %
E5a	1.175	-60 dBm	1.1775	- 49.8	8 %
E5b	1.206	off	off	- 49.3	0 %
E5b	1.206	-70 dBm	1.2081	- 49.7	5% - 6%
E5b	1.206	-60 dBm	1.2081	- 50.5	7%

Besides the power level as described above in Table 5 also results for the blanking rate are given. They are in the expected range.

In Figure 16 results for different thresholds for the temporal blanker are given in case of E5b processing. All tests besides this one were made with a threshold of 10 which was chosen to get a C/N_0 as high as possible in case of no interference. Thresholds lower than 10 causes in the interference free case a C/N_0 degradation (compare red curve). A threshold higher than 10 lead to a smaller C/N_0 in the case of interference (black curve) but gives no advantage in the interference free case. The blue curve shows the associated blanking rate. Note the blanking rate is very sensitive to the interferer's power.

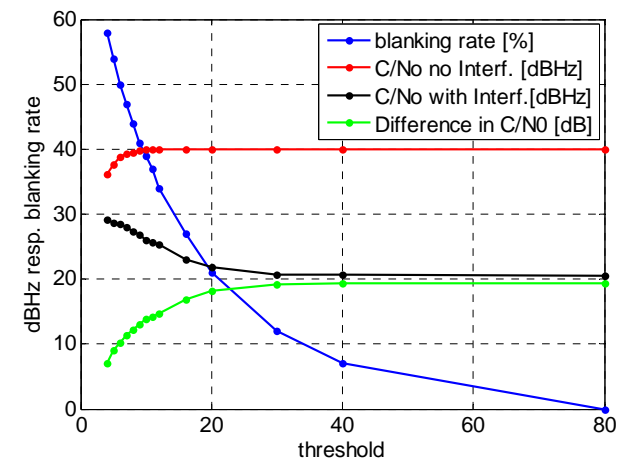

Figure 16: C/N_0 for different thresholds of temporal blanker

Table 6: Results for FDAF with different pulse types

	CW frequ. [GHz]	Pulse input power	Pulse frequ. [GHz]	Meas. power [dBm]	Pulse type
E5a	1.175	off	Off	-48.5	off
E5a	1.175	-70 dBm	1.1775	-48.7	Rect
E5a	1.175	-60 dBm	1.1775	-50.0	Rect
E5b	1.206	off	Off	-49.4	off
E5b	1.206	-70 dBm	1.2081	-49.7	Rect
E5b	1.206	-60 dBm	1.2081	-50.6	Rect
E5a	1.175	off	Off	-48.4	off
E5a	1.175	-70 dBm	1.1775	-48.8	DME
E5a	1.175	-60 dBm	1.1775	-49.6	DME
E5b	1.206	off	Off	-49.3	Off
E5b	1.206	-70 dBm	1.2081	-49.6	DME
E5b	1.206	-60 dBm	1.2081	-50.4	DME

In Table 6 results for the FDAF algorithm are given for two different pulse types. Again, the power level at the output of the AGC is very stable.

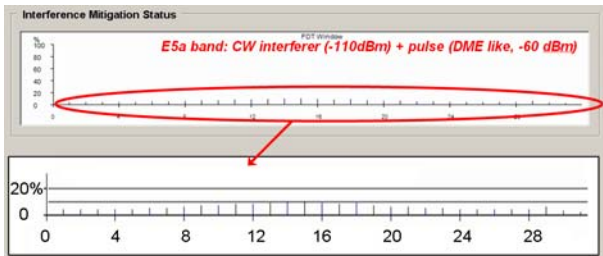

Figure 17: Report from receiver in case of FDAF testing with DME like pulses

Figure 17 shows as a screen shot of the receiver GUI in case of FDAF testing with 64 frequency bins. On the x-axis the number of the first half of the frequency bins is shown (the second half contains the same information). On the y-axis the percentage of blanking is given. In the extract (with additional auxiliary lines) it can be noticed that the blanking rate is for some cells in the range of 10% which is higher than theory predicts.

CONCLUSIONS

In contrast to a lot of the theoretical studies which make the incorrect hypothesis that the AGC is not affected by pulses, we used an adapted one. This one was developed by ENAC after numerical simulations [7]. In summary, the AGC algorithm seems to work fine for both, E5a and E5b frequency band and different interferer types. The power measured at the output of the AGC is more or less stable at -50 dBm whereas a conventional AGC would be affected by the test pulses.

Comparing E5a to E5b (with a smaller filter bandwidth) E5b is less degraded by DME/TACAN interference. For instance, without pulse blanking, the receiver lost signal tracking in E5a, but kept tracking in E5b. However, it must also be noted, that the tracking threshold is usually about 6 dB lower than the acquisition threshold, so that

in both bands the receiver could not (re)acquire the signals in case of strong DME without countermeasures.

The different pulse blanking techniques in time domain and frequency domain reduce the signal degradation due to pulsed interference by several dB. To choose the right threshold for the blanker is a trade of between the optimum in the interference free case and the disturbed case. If the threshold is very low also in the interference free case some useful signal is cut off but the advantage is a smaller degradation in the disturbed case. Exceeds the threshold a certain value no advantage can be gained any more: In the interference free case the complete energy is used but also the whole or at least significant parts of the interfering signal are also included in the following signal processing of the receiver. An interesting usage of this behavior could be to adapt the threshold online to the current environment of the receiver. This would enable a better C/N_0 in the disturbed case and no degradation in the not disturbed case. To enable an adaptive threshold robust interference detection is required. The loss of C/N_0 in the interference free case could be adjusted by a bigger gain in the receiving antenna. Further investigations of the behavior for different interference types are still necessary.

In comparison with theoretical and simulation results of [1] for the European hotspot and an aircraft at 40000 feet altitude the signal degradation with temporal pulse blanking in our measurements is more severe. For instance in [1] the C/N_0 degradation at E5a is 8.2 dB with an optimal blanking duty cycle of 28%, whereas in our case (with the threshold set to 10) the degradation is approximately twice as high combined with a higher blanking duty cycle. One reason for the difference could be that the interference power level in the test file according to the EUROCAE MOPS [4] is higher. This would also explain the higher blanking duty cycle in our case. For instance also results for 6 dB more interference power are provided in [1], where the duty cycle for the optimal blanking threshold is 54% and the C/N_0 degradation is 11.7 dB. Also the new AGC architecture could contribute to the different behavior. However, there remains still a difference of some dB. Another reason could be that the receiver architecture and parameters like correlator spacing and integration time in [1] are not exactly the same as in our case. On the other hand it is interesting to note, that with the FDAF technique our results are very close to the temporal blanking results in [1]. Most effective of the investigated blanking techniques is the FDAF technique in the frequency domain.

The observed differences to theory must be further investigated. In particular the interference measurements over the European hotspot end of this year within the frame of the ANASTASIA project will provide further data about the real interference level. The data which will be recorded during these

measurements will be directly fed into the test receiver together with simulated Galileo signals.

ACKNOWLEDGMENTS

The authors would like to thank the European Commission for funding this work, ENAC (Ecole Nationale de l'Aviation Civile, Toulouse) for processing some results and Skysoft (Portugal) for good software support.

REFERENCES

- [1] Frederic Bastide: Analysis of the Feasibility and Interests of Galileo E5a/E5b and GPS L5 Signals for Use with Civil Aviation, PhD Thesis, Ecole Nationale de l'Aviation Civile (ENAC), Oct. 2004
- [2] H. Denks, A. Hornbostel, J.-M. Perré: GNSS Receiver Testing Focusing on Strong Interference by Use of a Hardware Signal Simulator, Proc. of ION 08, Savannah GA, Sep. 2008.
- [3] A. Hornbostel, A. Konovaltsev, H. Denks, and F. Antreich: "Simulation of Multi-element Antenna Systems for Navigation Applications", IEEE Systems Journal on "Recent Advances in Global Navigation and Communication Satellite Systems" (GNCSS), to be published soon.
- [4] A. Hornbostel, H. Denks, A. Schroth, and M. Holbrow: "A New Signal Simulation Tool for Testing of Receivers with Controlled Reception Pattern Antennas", Proc. of ION 04, Long Beach CA, Sep. 2004.
- [5] EUROCAE: Interim Minimum Operational Performance Specification for Airborne Galileo Satellite Receiving Equipment, vs. 0.25, Oct. 2007.
- [6] GSA: Galileo Open Service ICD, Draft 1, February 2008
- [7] Mathieu Raimondi, INSA/ENAC, Olivier Julien, ENAC, Christophe Macabiau, ENAC: Characterization of FDAF for a GNSS Receiver. ENC 2008