

Aircraft to Ground Unidirectional Laser-Comm. Terminal for High Resolution Sensors

Joachim Horwath, Christian Fuchs

German Aerospace Centre (DLR), Institute of Communications and Navigation, Weßling, Germany.

ABSTRACT

Real-time monitoring allows new possibilities in applications like disaster management or traffic observation and guidance. The German Aerospace Center is currently developing an aircraft based observation system. Among other sensors a high resolution camera platform together with an optical downlink terminal is an integral part of the system. The optical terminal was tested in the first stage of expansion in November and December 2008. At distances up to 85 km the achieved mean tracking offset with pure CPA tracking was 266 μ rad. Initial communication tests have been successfully performed up to a distance of 40 km.

Keywords: Aircraft Laser-Communication Terminal, Flight Experiments;

1. INTRODUCTION

1.1 Motivation and project background

A typical problem for large-scale events and disasters like floodings or earthquakes is the lack of up-to-date information for the incident area. The German Aerospace Center (DLR) is therefore developing a decision support and information system for crisis- and traffic managers. Information about the target area and especially the critical infrastructure like roads is extracted and processed automatically. Emergency services can then be navigated fast for example.

The ARGOS Project (airborne wide area high altitude monitoring system) is based on high resolution daylight cameras onboard a DLR research aircraft. At night-time or during poor visual conditions, an X-, C-, S-, L- and P-band multichannel full polarimetric active radar sensor (SAR) is utilized. Such high resolution sensors gather considerable amounts of data. Therefore communication links to the ground station with appropriate data rate become a key element for such a real time system. Beside a microwave link system a free space optical communication system will be used for data transmission from the aircraft.

In general, free space optical data transmission technology for airborne applications has gained more and more attention in the last years. The JPL worked on an optical terminal for an UAV [1], and ITT has manufactured a bidirectional terminal under the ESTER Program [2]. However, apart from the French LOLA program, where an optical communication link between a GEO satellite and an aircraft has been demonstrated [3], no publications or results from flight testing campaigns are known to the authors.

1.2 Design specification

The maximal data rate for the link system is determined by the onboard instruments. The SAR sensor is compatible with the 40Mbit/s microwave link which is important for the all-weather operability. The operating conditions for the optical camera system correlate with the availability of the optical link. Therefore, the optical communication terminal was mainly designed according to the current needs of the camera system. The resolution of the camera system is 48 MPixel (area sensor) and a refresh rate of 5 Hz is necessary to automatically derive vehicles with speed vectors from the serial images for instance. A resulting data rate of 125Mbit/s (Fast Ethernet) was therefore the design goal for the optical communication terminal. This data rate is of course a moderate data rate for optical links, but it is already above the limit what can be achieved with civil microwave links in terms of available spectrum. Furthermore, it is sufficient for the foreseen application scenario and the flexible system design allows an increase of data rate with only little modifications.

2. SYSTEM DESCRIPTION

The aircraft chosen for the ARGOS system is the Do228, a short take-off and landing type aircraft with twin turboprop engines and a service ceiling of 28000ft (8534m). The vibration spectrum of such aircraft types is more demanding compared to those of jet planes. The shock waves of the propeller blades produce vibrations when impinging on the aircraft cabin. Fig. 1 shows the vibration spectrum of the aircraft in z- (gravitational-) direction without gravitation offset. There are two main vibrations at 25.4Hz with 13.62 m/s^2 and its 4th harmonic at 101.4 Hz with 20 m/s^2 . These peaks are due to the main engines rotational speed of about 1522 RPM with the mounted 4-Blade propellers.

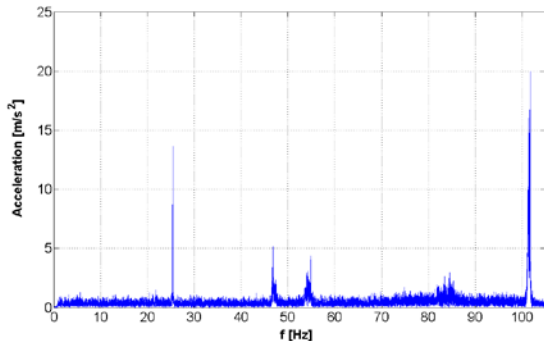

Fig. 1. Example of the aircraft vibration spectrum.



Fig. 2. The mounting plate with the dome assembly. Sketch shown without the terminal cover.

The terminal is installed above a standard body hole of the aircraft and is a further development of the Free-space Experimental Laser Terminal (FELT) [5] plus adaptation to this scenario. The optical path is fed through the hole to the coarse pointing assembly (CPA). The design comprises three main parts: the outer housing with the mounting plate and dome assembly (Fig. 2), the CPA along with a mounting cylinder, and the optical bench (Fig. 4). In order to isolate the optical system mechanically and damp the vibrations the whole optical system is mounted on eight shock mounts. The resonant frequency of the system has been set to 8 Hz, well below the first vibration peak. This results in an attenuation of 16.5 dB at 25 Hz and thus the aircraft's vibrations are damped fairly well.

The dome assembly consists of the optical transparent glass dome with a radius of 115 mm and two cylinders. The lower cylinder with the dome flange and the dome itself are the terminal parts exposed to the air flow. The upper part of the cylinder with smaller diameter is attached to the mounting plate. The mounting plate is fixed to the aircraft's seat rail.

The CPA is mounted inside the dome assembly. The CPA is a proprietary design and uses very agile hollow shaft torque motors with precision encoders, a development of DLR's robotic department. The main advantage is that the design does not have gears and therefore totally eliminates mechanical play. The design also features unlimited travel in both axes. With an aperture of 30 mm, the Coudé Path of the CPA is directing the beam via the collimation optics to the optical bench (Fig. 3). For the installation of the system on the aircraft the whole dome assembly with the CPA is inserted into the aircraft body hole and mounted on the mounting plate via the CPA mounting interface. The interface also contains all electrical connections. In this way the optical terminal can be installed fast and easy.

The collimation and coupling system as well as the tracking sensors and filters etc. are mounted on the optical bench. The transmission wavelength of the terminal is 1550 nm with an output power of 100 mW. For the first stage of expansion no Fine Pointing Assembly (FPA) is installed. Therefore just the InGaAs acquisition FPA sensor is installed at the moment and used for acquisition and tracking. The available field of view (FoV) on the optical bench without beam truncation is about 52 mrad. The optical system of the tracking sensor is matched to this large FoV. Therefore a standard inertial measurement unit without high precision requirements can be used to get initial values for pointing toward the ground station prior to the acquisition scan.

The terminal computer is a compact PCI PC with real time operating system. The computer controls the acquisition sensor and CPA and interfaces with the IMU and TeleMetry and TeleControl system (TMTC). The TMTC-System is a bidirectional RF-link system (RS-232) to the ground station which will be used to control the optical terminal from the

ground station. The terminal computer also sends the GPS information of the aircraft via the TMTC link to the ground station. Additionally to the terminal computer, industrial microcontrollers are used to interface with the Electronic Power System (EPS) and the optical transmitter and amplifier module. They can remotely boot and reboot the terminal computer and power up and down all other system components. Additionally they provide temperature information of all systems and status information of the transmitter and amplifier module. The transmitter module consists of a 1 mW intensity modulated (OOK) laser diode and 2 EDFAS with 100 mW optical output power each which are used for two different beam divergence angles. At one optical output channel an additional 635 nm CW laser with 10 mW output power is coupled into the same transmission system. This laser is mainly used for calibration purposes.

Media converters process the fast Ethernet input signal to a serial signal with 8B/10B encoding for the optical transmitter and amplifier module. In order to cope with the atmospheric fading channel special packet layer forward error correction is used.

The second part of the ARGOS optical communication system is the transportable optical ground station (TOGS). The ground station consists of a 40 cm Cassegrain Telescope and has been used in a similar configuration as described in [1] except that the beacon wavelength has been changed to 1590 nm. The TOGS will not be described in more detail here. A picture of the TOGS is visible in Fig. 7. Due to the fact that the communication- and the beacon wavelengths are in the 15xx nm range, a good eye-safety is achieved with this approach.

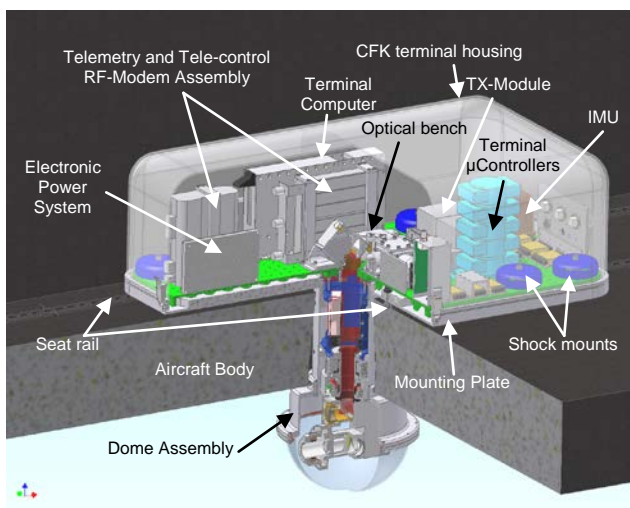

Fig. 3. Sectional view of the optical terminal.

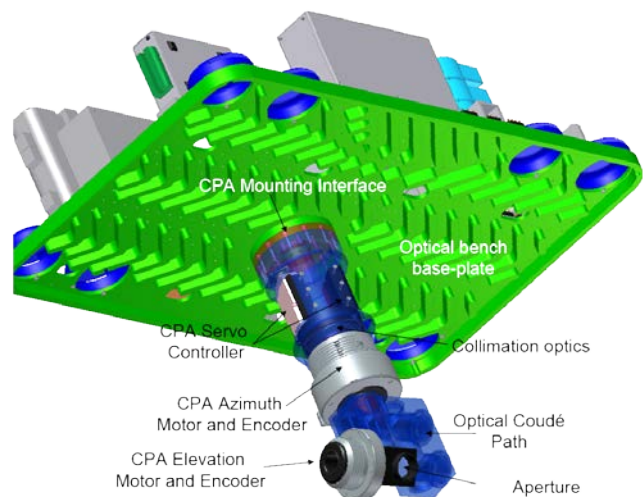

Fig. 4. Sketch of the shock mounted terminal part without housing: optical bench and CPA.

3. FIRST FLIGHT-TEST-CAMPAIGN

3.1 Preparation

The terminal construction started in early 2008 after a short initial study phase performed in 2007. The terminal was finished in autumn 2008. In parallel the flight certification process with the German aviation authorities took place. Static load and electromagnetic compatibility testing have been performed in the flight configuration with the aircraft. Prior to the first flight test campaign several ground to ground tests with a vehicle have been performed in order to test all system components and to fine tune the CPA tracking system. After a small revision of the terminal lightning protection concept, the aviation approval documents have been received and the trial could start.

3.2 Overview

The goal of the first flight test campaign was to test the operability and especially the acquisition and tracking of the optical link system and to make initial measurements. A two week flight test campaign has been carried out at the end of November/beginning of December 2008. The region south of the DLR premises in Oberpfaffenhofen, southwest of Munich, Germany, has been chosen for the test flights.

After the first aerodynamic test flights, where no experiments have been performed, a total of 9 measurement flights in the 2-week period have been performed. Fig. 5 shows the optical terminal mounted on the aircraft.

For practical reasons the measurement flights have been performed in the non-controlled airspace most of the time in order to have more freedom to perform different flight maneuvers without approval from flight controllers. Thus visual flight conditions were required and the flight altitude was limited to maximal 3000 m. The surface temperatures at the TOGS were in the range of 0°C to +5°C and the aircraft velocity was always around the nominal cruise speed of 100m/s.



Fig. 5. The optical terminal mounted on the aircraft. The pointing assembly with the dome is mounted on the front part of the aircraft, left of the nose landing gear.



Fig. 6. The DLR research aircraft DO 228 during transmission tests. The picture is taken with a daylight camera equipped with telephoto lens and shows the red calibration Laser-beacon. This beacon is usually just used on ground for calibration purposes and can be activated additional to the modulated IR-signal.



Fig. 7. The Transportable Optical Ground Station (TOGS) at the DLR premises in Oberpfaffenhofen, Germany
Front: RF-Link Rx-Antenna for TMTC Link
Back: 40cm Cassegrain Optical Ground Station

3.3 Results

The trials can be considered as great success. The acquisition process worked very reliable and the tracking has been tested up to 85 km. No stable data communication was expected without installed FPA at the aircraft terminal. However, error free data communication with a beam divergence of 2 mrad was achieved at link distances up to 30 km and with slightly increased error rates at higher distances. Fig. 6 shows the aircraft with the terminal's red calibration laser beacon during the trials.

For the test campaign an additional power sensor has been installed at the terminal in order to measure the received optical power from the ground station beacons. Fig. 8 shows the flight trajectory of the evaluated data. A straight path of the trajectory has been chosen for the evaluation. The link distance reached from 67.4 km to 73.4 km. An example for a received eye pattern after the limiting amplifier is shown in Fig. 9.

In Fig. 10 some evaluated data are shown. The upper graph is the received power, the middle graph is the pointing error and the lower graph is the roll angle of the aircraft respectively the terminal. The power received at the aircraft has been subject to strong fading, since the aperture averaging effect of the 30 mm aperture is quasi not existent to eliminate strong fades and surges and the link is operating in the saturation regime. However, the received mean power which is in the range of 15 nW is the expected power in terms of link budget calculations. It should be mentioned that the shown power surges are clipped by the limited dynamic range of the power sensor.

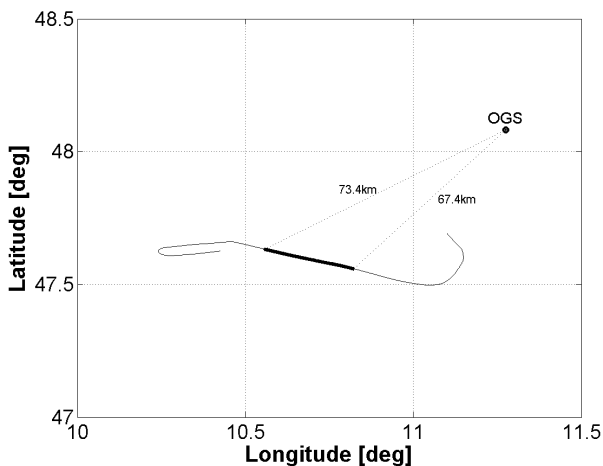

Fig. 8. Part of the Flight Trajectory during the discussed measurement flight. The thick painted part corresponds to the data shown below. It has been gathered during straight flight at distances from 67.4km to 73.4km.

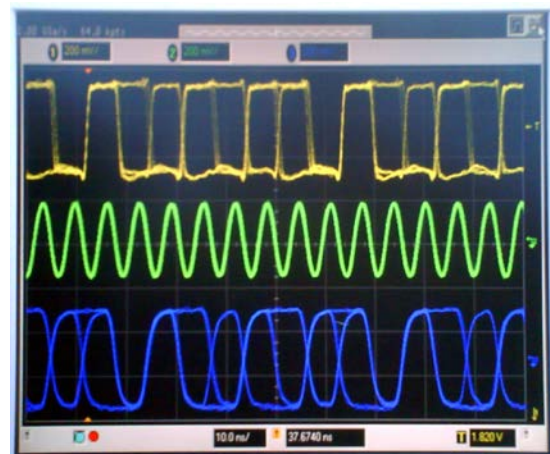

Fig. 9. Received Signal at OGS
Top: Received Signal after Limiting Amplifier
Middle: Recovered Clock Signal
Bottom: Recovered Data Signal

The pointing error was most of the times below 1mrad. The mean pointing error was 266 μ rad, although the aircraft's roll angle (bottom) was subject to relatively fast and large fluctuations. The roll angle was the most influencing angle since the flight trajectory was from east to west with the CPA pointing to north. With the current beam divergence of 2 mrad and the used forward error correction, a stable communication link is possible.

However, the parameters of the tracking system can still be further optimized. By using a Fine Pointing Assembly (FPA) in the next development stage of the terminal, it will be possible to further reduce the pointing error and thus a more stable tracking and a smaller beam divergence is possible.

During turns of the aircraft the tracking system showed a relatively constant contouring error with pointing errors in the range of 1 mrad. This can be overcome with further improvement of the control loop setup.

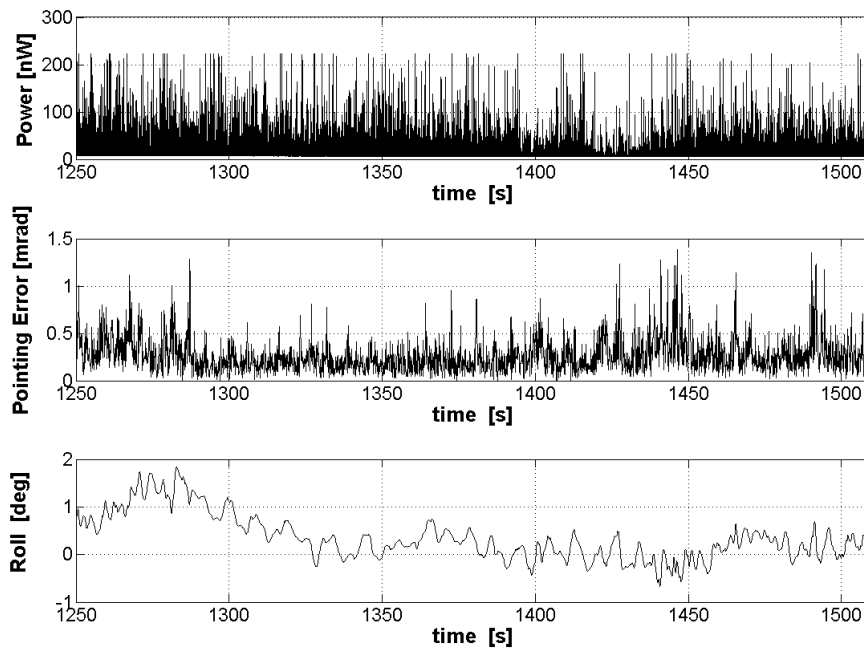

Fig. 10. Measurement Results on the optical terminal
 Top: Beacon Power received by the Optical Terminal
 Middle: Pointing Error calculated from Tracking Camera Data
 Bottom: Roll Angle of the Aircraft

4. CONCLUSIONS AND OUTLOOK

An optical laser communication terminal for airborne applications has been developed and its operability has been demonstrated in a flight test campaign. The acquisition process between the airborne optical terminal and the optical ground station has been accomplished at link distances up to 85 km. Furthermore, data transmission has been shown over a wide range of link distances even without the planned fine pointing assembly. The average pointing error was 266 μ rad during normal flight conditions.

One of the next steps before carrying out further tests in spring 2009 will be the implementation of a Fast Steering Mirror as Fine Pointing Assembly (FPA). It will allow the suppression of high frequency spectral components that remain although a mechanical damping is in place. Furthermore, the FPA will be useful in flight situations in which the aircraft is performing dynamic flight maneuvers.

The expected increase in Pointing Stability with FPA will moreover allow decreasing the terminal's beam divergence, resulting in a system with considerably higher link margin. As the application scenario is not requiring a higher data rate than 100MBit/s, an increase of data rate is not needed according to the project goals. However, it is foreseen in the test roadmap to demonstrate data rates of higher than 1GBit/s.

5. ACKNOWLEDGMENT

The authors would like to thank the German Aerospace Center transportation programme directorate and the flight operations department for their kind support. Furthermore special thanks to the core trial team: Martin Brechtelsbauer, Bernhard Epple, Dirk Giggenbach, Hennes Henniger, Markus Knappek, Florian Moll and Nicolas Perlot.

REFERENCES

- [1] Ortiz, G., G., Lee, S., Monacos, S., Wright M., Biswas, A., "Design and development of a robust ATP subsystem for the Altair UAV-to-Ground Lasercomm 2.5 Gbps Demonstration" Proc. of SPIE, , (2003).
- [2] Gangl, M., E., Fletcher, T., M., Cunningham, J., A., Foulke, D., Fisher, D., S., Grinch, D., Jeri, D., Hopf, D., Goode, T., Baber, D., "Fabrication and testing of laser communication terminals for aircraft" Proc. of SPIE 6243, 624304 (2006)
- [3] Cazaubiel, V., Planche, G., Chorvalli, V., Le Hors L., Roy, B., Giraud, E., Vaillon, L., Carré, F., Decourbey E., "Lola: A 40.000 km Optical Link between an Aircraft and a Geostationary Satellite", Proc. of 6th Internat. Conf. on Space Optics', ESTEC, Noordwijk, ESA SP-621, (2006)
- [4] Knappek, M., Horwath, J., Perlot, N., Wilkerson, B., "The DLR Ground Station in the Optical Payload Experiment (STROPEX) - Results of the Atmospheric Measurement Instruments" Proc of SPIE, 6304, 63041U (2006)
- [5] Horwath, J., Perlot, N., Knappek., M, Moll, F., "Experimental verification of optical backhaul links for high-altitude platform networks: Atmospheric turbulence and downlink availability" International Journal of Satellite Communications and Networking, 25(5), 501-528, (2007)