

TANDEM-X AUTONOMOUS FORMATION FLYING SYSTEM

Jean-Sébastien Ardaens⁽¹⁾, Simone D'Amico⁽²⁾, Dieter Ulrich⁽³⁾, Denis Fischer⁽⁴⁾

⁽¹⁾ German Space Operations Center (DLR/GSOC, 82234 Wessling, Germany); jean-sebastien.ardaens@dlr.de

⁽²⁾ same address as ⁽¹⁾; simone.damico@dlr.de

⁽³⁾ EADS Astrium GmbH (88039 Friedrichshafen, Germany); dieter.ulrich@astrium.eads.net

⁽⁴⁾ same address as ⁽²⁾; denis.fischer@astrium.eads.net

ABSTRACT

The TanDEM-X mission is a scientific and commercial Earth observation mission comprising two satellites flying in close formation. Even if the control of the formation motion was originally foreseen in a ground-in-a-loop scheme only, the benefit of using an onboard autonomous formation keeping system has rapidly become evident. As outlined in the paper, onboard autonomy guarantees superior orbit control performance, short reaction time to contingencies, and an increase of the data product quality. After presenting the motivation, concept and architecture of the TanDEM-X Autonomous Formation Flying (TAFF) system, the paper discusses the integration of TAFF into the already existing spacecraft design. Minimum changes of onboard software and hardware have enabled the design of an autonomous system which makes maximum use of the available resources. TAFF is currently being developed by the German Aerospace Center (DLR) and Astrium GmbH and will substitute the ground-based formation keeping activities during routine operations.

1. INTRODUCTION

1.1. The TanDEM-X Mission

The TanDEM-X mission comprises two Synthetic Aperture Radar (SAR) satellites flying in close formation. SAR interferometry allows high resolution imaging of the Earth by combining two images acquired from two slightly different positions [1]. The first satellite, called TerraSAR-X (TSX), has already been launched in June 2007 into a 514 km sun-synchronous dusk-dawn orbit with 97° inclination and an 11 day repeat cycle. It currently works as a repeat-pass interferometer in the frame of the TerraSAR-X mission. It will be supplemented in 2009 by a second satellite, called TanDEM-X (TDX), in order to form a single-pass interferometer and give birth to the TanDEM-X formation flying mission. The primary objective of TanDEM-X is the generation of a global high precision Digital Elevation Model (DEM). For this purpose, a simultaneous SAR acquisition from the two spacecraft is required with flexible baselines between hundred meters and several kilometers.

The formation flying configurations have been designed to satisfy the challenging requirements in terms of baseline size and versatility while minimizing the collision risk. To that end, slightly different nominal orbits are selected for the two satellites. Semi-major axis and inclination are chosen to be identical in order to establish close relative orbits that are passively stable (i.e. with minimum impact of Earth's oblateness perturbations). On the contrary eccentricity, argument of perigee and right ascension of the ascending node differ and provide, as a consequence, a natural elliptic relative motion whose shape depends directly on the size and orientation of the eccentricity and inclination vectors [2]. A proper selection of the so-called relative orbital elements guarantees a natural safe relative motion that fulfills the baseline requirements [2].

The formation is however affected by perturbations such as differential drag and Earth's oblateness which tend to deform the relative geometry and, in the worst case scenario, to bring the formation into a high collision risk configuration. The relative motion needs to be controlled by the only active TDX spacecraft which will have to perform small correction maneuvers to compensate the differential forces acting on the two satellites. In addition TDX will have to replicate the absolute orbit control maneuvers performed by TSX that are planned by the ground-segment in order to maintain its frozen repeat orbit as close as possible (≤ 250 m) to a predefined reference trajectory.

During the early phases of the mission the control of the formation will be performed by the ground-segment. In order to limit the cost of the mission, only two ground-stations situated in Germany will be available for routine operations, allowing a few ground contacts per day. This introduces a severe limitation for a ground-in-the-loop orbit control scheme whose reaction time is inevitably long allowing maneuver cycles of 12-24 hours only. In order to improve the overall performances of the relative orbit control, TDX will be equipped with a real-time onboard autonomous formation keeping module, called TAFF, which will make use of the MosaicGNSS receivers available on the two spacecraft, an additional Inter Satellite Link (ISL)

antennas and a cold-gas propulsion system to plan and execute orbit control maneuvers autonomously with a higher frequency (i.e. every 2-5 orbital revolutions).

1.2. Motivation and Objectives of the TanDEM-X Autonomous Formation Flying (TAFF) System

TanDEM-X represents an ideal opportunity to apply the existing competence in the field of autonomous navigation and formation flying to a simple system solution on a scientific mission and to demonstrate the substitution of ground-based tasks by onboard functionalities. The TAFF system will demonstrate how cost-savings for future formation flying missions can be realized by adopting advanced guidance, navigation and control technologies. In its basic form, TAFF represents a technology transfer to the German space industry, and demonstrates the DLR's potential to develop innovative technology.

The usage of TAFF brings a multitude of benefits to the TanDEM-X mission. In particular the improvement of the relative orbit control accuracy will increase the quality of the scientific and commercial data products. On top of ensuring a stable and more precise baseline for SAR interferometry, TAFF will enhance the exploitation of along-track interferometry techniques. Along-track interferometry is enabled by a special configuration of the formation which provides dedicated oscillating along-track separations at desired locations along the orbit. This method improves the detection, localization and the signal ambiguity resolution for ground moving targets and can be used for traffic monitoring applications [3].

Overall TAFF will ease the ground and space operations. Its accurate orbit control performance facilitates the synchronization of the two SAR systems

via dedicated horns. In fact the positions of the satellites will be known with a good precision well in advance of real operations. TAFF will enable a safe and robust formation control with minimum collision risk. Furthermore real-time collision risk assessments will be performed by TAFF on a routine basis in order to support automated Fault Detection Isolation and Recovery (FDIR) tasks.

1.3. Cooperation between Astrium and DLR/GSOC

The TanDEM-X project is realized in a public-private partnership by DLR e.V. and EADS Astrium GmbH. The cooperation between the two companies is intensive regarding the development of TAFF. The TAFF subsystem will be merged into the Attitude and Orbit Control System (AOCS) and will be developed following the stringent coding rules of the ECSS standards for embedded space applications [4].

The DLR German Space Operations Center (GSOC) is in charge of the complete TAFF algorithm design, development and specification. On top of that GSOC will perform extensive testing of the resulting prototype software as a standalone unit, isolated from the full onboard software.

Astrium GmbH will perform the final coding of the TAFF software, the integration into the TDX onboard computer and the testing of the all system. The cooperation requires a common understanding of the requirements and constraints, a precise definition the interfaces to enable a harmonious integration within the complete onboard software and common tools to exchange data. The development environment described afterwards is the result of the efforts made to have a common working platform for this joint venture.

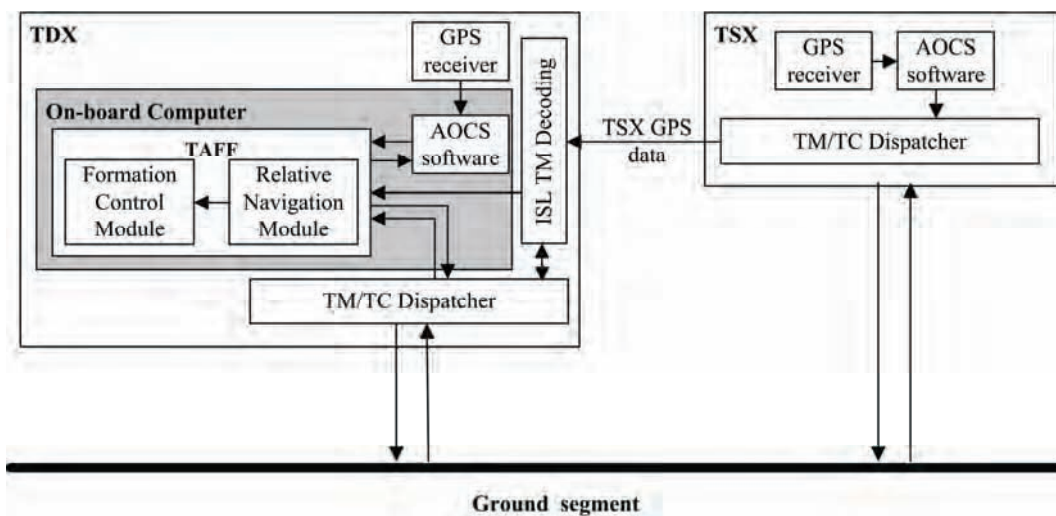

Figure 1. Overview of the ground and space segments and their interface to TAFF

2. SYSTEM ARCHITECTURE

2.1. The TanDEM-X Space Segment

The space segment comprises the two satellites TSX and TDX. Apart from a few adaptations, TDX is a 1:1 replica of TSX. The satellites have a size of 5m x 2.4m, a mass of approximately 1350 kg and carry a high-resolution SAR radar operating in the X-band (9.65GHz). Two GPS receivers are installed on each spacecraft. The dual frequency IGOR GPS receiver of BroadReach Inc., which serves exclusively scientific purposes and the single frequency MosaicGNSS receiver of Astrium, whose navigation data are used by TAFF.

A one-way inter-satellite link (ISL) has been established between the two satellites, using the existing S-Band Downlink System on TSX and an additional receiver on TDX. The link is intended to work up to a few kilometers (ca. 2-5 km). A spherical coverage of the link is generally possible with exclusion zones in which the transmission of data is not possible due to the relative orientation of the spacecraft and their distance. The onboard computer is a fully redundant unit that aims at performing the onboard data handling and the attitude and control functions on the satellites. The processor module is based on the ERC32, clocked at 20 MHz, and ensures an execution of software with a processing capability of more than 10 MIPS. The internal RAM memory comprises 6Mbytes, with 4Mbytes used nominally and 2 Mbytes reserved for the implementation of a cold redundancy. The communication design for TanDEM-X is based on a conventional S-Band scheme. Telemetry signals received from the active encoder of the onboard system are binary phase shift keying-modulated and transmitted by the active transmitter. Radio frequency signals received from the antenna are demodulated and routed to the command decoders of the on-board computer.

The hydrazine propulsion system is common to TSX

and TDX. It consists of two branches of four 1N thrusters each which are operated in cold redundancy. TDX has in addition a cold gas propulsion system for the maintenance of the formation. It consists of 8 thrusters, arranged into 2 redundant branches of 4 thrusters, pointing in flight and anti-flight direction, with a nominal thrust of 80 mN.

The TAFF subsystem resides in the TDX onboard computer (cf. Figure 1). TAFF gets as inputs the GPS data provided by the GPS receiver onboard TDX and, through the ISL, also from the GPS receiver onboard TSX. TAFF uses the cold gas propulsion system to control the formation and performs in-plane control maneuvers in flight and anti-flight direction only.

2.2. Algorithm Concept and Structure

The design of TAFF is driven by tight requirements in terms of usage of onboard resources. TAFF represents an extension of the existing TDX software and has to fulfill requirements on the code size, on the memory usage and on the computational load. In addition the TAFF algorithms have to be simple and robust.

This is achieved by a streamlined navigation and control concept. The feedback control law implemented by TAFF is impulsive and deterministic. The impulsive maneuvering avoids cold gas thruster activities during most of the orbit arc and limits interferences with SAR data acquisition. The relative orbit control maneuvers are nominally performed at a fixed frequency as a couple of thrusts separated by half an orbital revolution [5]. The control law is based on the concept of relative eccentricity/inclination vector separation [6], which enables a robust formation configuration with minimum collision risk.

As depicted in Figure 2, the Formation Control Module is fed with an estimate of the relative orbital elements generated by the Relative Navigation Module. The latter implements an Extended Kalman Filter (EKF) and

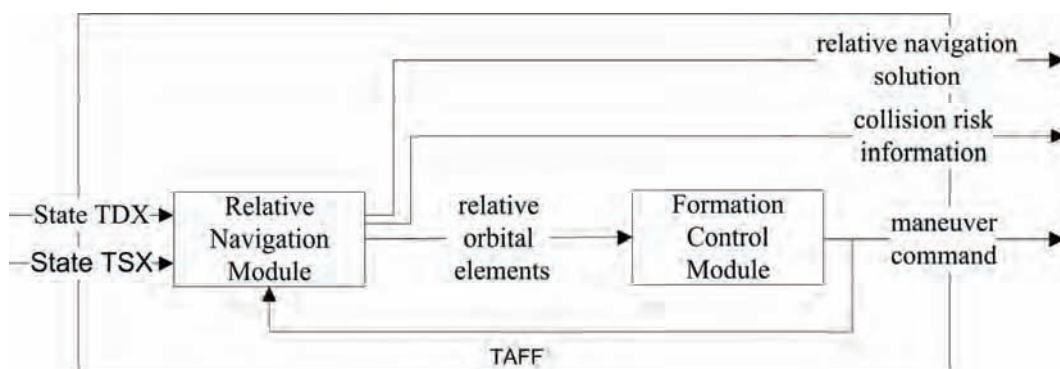

Figure 2. Simplified TAFF software architecture

filters the navigation solutions provided by the GPS receivers onboard TDX and TSX. The usage of navigation solutions has been preferred to the processing of raw pseudorange and/or carrier phase data for a matter of simplicity and to minimize the amount of information exchanged via the ISL. The navigation solutions are affected by errors on the order of 10m, 1 σ and can not be used directly to compute the relative orbital elements. Furthermore TAFF is required to cope with ISL data gaps of up to several minutes. This is achieved by the implementation of an EKF in combination with a linear dynamic model based on the Hill-Clohessy-Wiltshire (HCW) equations. In particular the relative motion is parameterized through a set of relative orbital elements obtained by combining the Keplerian elements of the two spacecraft (identified in the following by the subscript $k=1,2$).

$$\Delta\alpha = \begin{pmatrix} \Delta a \\ a_1\Delta e_x \\ a_1\Delta e_y \\ a_1\Delta i_x \\ a_1\Delta i_y \\ a_1\Delta u \end{pmatrix} = \begin{pmatrix} a_2 - a_1 \\ a_1(e_2 \cos(\omega_2) - e_1 \cos(\omega_1)) \\ a_1(e_2 \sin(\omega_2) - e_1 \sin(\omega_1)) \\ a_1(i_2 - i_1) \\ a_1(\Omega_2 - \Omega_1)\sin(i_1) \\ a_1(u_2 - u_1) \end{pmatrix} \quad (1)$$

represents the state of the EKF and combines the information coming from the semi-major axis a_k , the eccentricity e_k , the inclination i_k , the argument of perigee ω_k , the right ascension of the ascending node Ω_k and the mean argument of latitude u_k . The state defined by (1) describes uniquely and unambiguously the formation geometry and can be used to express in a convenient way the solution of the HCW equations of motion [6],[7]:

$$\begin{cases} \frac{\Delta r_R}{a} = \Delta a/a - \Delta e_x \cos u - \Delta e_y \sin u \\ \frac{\Delta r_T}{a} = \Delta u + \Delta i_y \cot i - \frac{3}{2} \frac{\Delta a}{a} (u - u_0) - 2\Delta e_y \cos u + 2\Delta e_x \sin u \\ \frac{\Delta r_N}{a} = -\Delta i_y \cos u + \Delta i_x \sin u \end{cases} \quad (2)$$

Here, Δr_R , Δr_T and Δr_N are the component in radial, along-track and cross-track directions of the relative position and u is the mean argument of latitude of TDX. This model is able to predict the relative motion of the formation over several orbits with accuracy at the meter level and is used by the EKF to provide a smooth and accurate relative navigation solution. As shown in the next sections the achieved relative navigation accuracy is one order of magnitude better than the original GPS navigation solutions.

On top of feeding the Formation Control Module, the output of the Relative Navigation Module serves other subsystems onboard the spacecraft. In particular Eq. (2)

is used to provide a prediction of the collision risk throughout the course of the mission. The relative orbital elements describe the shape and dimensions of the elliptic relative trajectory and are used to compute the expected minimum separation during the next orbital revolutions. The violation of predefined thresholds trigger the FDIR system onboard TDX to prevent a possible collision between the spacecraft.

2.3. Operational Aspects

Due to the lack of experience in operating closely flying LEO satellites, TAFF will be activated gradually. In particular TAFF has been designed to support four operational modes: off, navigation-only, open-loop and closed-loop. The first testing phase will assess the in-flight performance of the navigation module. The Relative Navigation Module must be robust and reliable in all conditions. The navigation process has to autonomously incorporate orbit control maneuvers and detect any potential problems. Afterwards, TAFF will be switched to open-loop mode. In this mode, the Formation Control Module is activated, computes the necessary orbit control maneuvers although they are not executed. Extended monitoring and analysis using telemetry is then performed to assess the behavior of the algorithm in real conditions. If these two phases are successful, TAFF will be then switched to closed-loop mode and will finally substitute the ground-based orbit control activities.

3. INTEGRATION OF TAFF INTO THE TDX SATELLITE

3.1. Software Implementation Constraints

When starting the first discussions between the GSOC Space Flight Technology department and the Astrium TanDEM-X team about a possible implementation of an autonomous formation flight, it became obvious that the algorithms which are under investigation for the ground controlled formation flight need to be adapted for an on-board implementation. The TanDEM-X Onboard Computer and the On-board software should be fully based on the existing TerraSAR-X components. Due to the project constraints the new functionality had to be implemented into the existing blocks. Although it turned out during the TerraSAR-X system level testing that processor runtime was not critical at all so far, the margins should be maintained in order not to jeopardize the stability of the realtime software proven in the system tests. The RAM margins instead were already close to the margins and some optimization became necessary to free some memory for the TAFF. Therefore a clear and hard requirement was formulated for the new algorithm: The overall run-time per second should not exceed 30 msec and the allocated RAM area should stay within 100 kByte. Prototyping of a down-scaled algorithm and intensive testing was performed

before a final go ahead could be given for the implementation of onboard autonomous formation flight. The next discussions aimed at defining the software interfaces in a way that the impact on the existing AOCS software is reduced to a minimum. In addition it needed to be respected that a ground controlled commanding of formation flight maneuvers remained the baseline for mission operations. Thanks to the rigorous modular design of the TerraSAR-X software the functional interfaces could be clearly defined. The intersatellite link receiver/decoder is considered like an additional AOCS sensor providing mainly the GPS based orbit position solution of the TerraSAR-X satellite together with some satellite status information (ISL data in Figure 3). The data extracted from the TSX housekeeping packets is checked for consistency and validity and written into a dedicated data structure. Together with the position and status data available within the TanDEM-X AOCS software this forms the input for the TAFF module. The final outputs from the TAFF are the formation flight maneuver commands to the TDX cold gas system. These have the identical structure and content as the ground based telecommands and are submitted to the same TC checks within the AOCS software before execution.

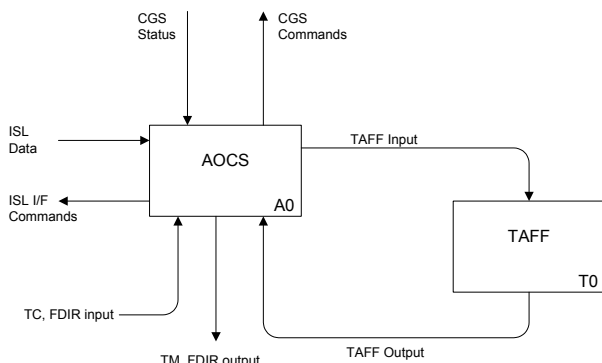

Figure 3. AOCS TAFF interaction

Further on the TAFF algorithm provides housekeeping packets for regular monitoring and debugging purposes according to the TerraSAR-X packet utilization standard (PUS) definitions. Parameters which should be monitored on-board to decide on the integrity of the system are defined and made available to be used by the implemented FDIR.

3.2. TAFF Connections and Interfaces to the TDX AOCS

No separate AOCS mode for execution of constellation maintenance maneuvers will be implemented. The maneuvers will be executed in nominal operation mode of the satellite. If the spacecraft is in any another mode, e.g. safe mode or orbit control mode, commands to the

cold gas thrusters issued by TAFF will be blocked by the AOCS. This ensures that the spacecraft will always have the correct orientation for execution of the tangential maneuvers. The influence of yaw steering on the maneuver performance has been evaluated and is considered negligible. The execution of constellation maintenance maneuvers in nominal operation mode has no influence on pointing performance. The wheels compensate the torque caused by misalignment and unbalance of the cold gas thrusters.

3.3. Extension of the Satellite FDIR to Cover TAFF

The TerraSAR-X on-board FDIR functionality is logically organized in 5 levels and on top the Ground having the highest authority, in case telecommanding is possible. The hardware protection level may override the software functionality and as such should be the ultimate recovery action only (e.g. latching current limiter, Disconnect Non-Essential Loads (DNEL) etc.). Level 1 and 2 are implemented using the PUS services “monitoring” and “event/action” as well as optionally the on-board command procedures (OBCP). These levels comprise standardized table driven decision logics to react on the status of on-board acquired or derived parameter with events and, if configured accordingly, with TC based reactions. A default set of FDIR logic is hard-coded in the software but the overall logic is fully configurable from Ground without software modification. Instead, the level 3 implementation is part of the coded software functionality and is mainly used for immediate algorithm depending decisions in case of non-nominal behavior of input or status data. An example is the decision to use an on-board propagation instead of a missing or invalid sensor signal. The lowest level comprises all checks within low level functions which are immediately corrected on this level without having an impact on the system level (typical example is the Error Detection and Correction (EDAC) protection of memories).

For the TAFF implementation, the above concept is rigorously applied. The level 3 FDIR is integral part of the TAFF algorithm, checking e.g. the availability and consistency of the satellites position information and performing a propagation of the relative motion in case of missing data. For any other possible non-intended situation logical or numerical parameters are derived by the algorithm which allow monitoring of the algorithm status on Ground and on-board. This comprises parameters to judge the stability of the navigation filter or the time of last valid position update from the GPS receiver. Those parameters are used by the on-board monitoring of the AOCS software (level 2) to command pre-defined reactions, like “Reset filter” commanding or even taking the TAFF out of control.

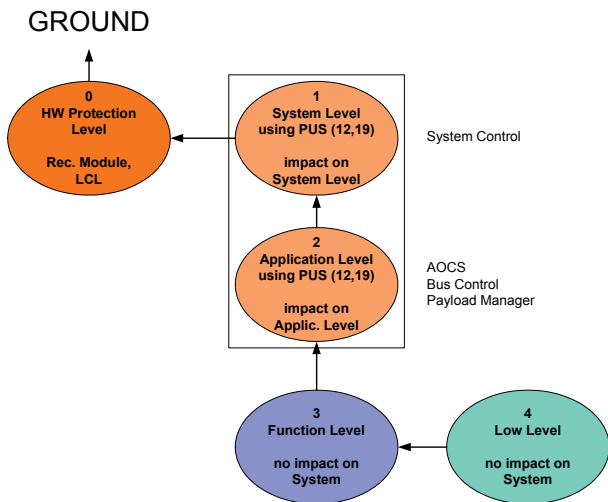

Figure 4. Multi Level FDIR Concept

Another important parameter derived within the navigation part of the algorithm part is the “collision risk parameter”, indicating that the separation conditions for a safe formation flying are no longer fulfilled and within a limited number of orbital revolutions the risk for collision may increase. In this case the System Level FDIR (level 1) should “decide” to break off the formation and issue the necessary commanding to initiate relative along track drifting, which then allows the Ground to take over. Detailed analyses are still going on to define these safety reactions. The aim is to achieve in simple and robust, but nevertheless ultimately safe reactions.

4. PROTOTYPE SOFTWARE DEVELOPMENT

4.1. Development Environment at DLR\GSOC

Special attention has been given to the definition of the prototype software development environment. As mentioned before, DLR\GSOC is in charge of providing an algorithm specification. Providing a set of procedures and mathematical equations on a sheet of paper gives a lot of freedom to the implementation. Indeed, no choice is made regarding the programming solutions used to realize the functionalities. On the other hand, the development of a prototype software needs to incorporate libraries like e.g. vector/matrix operations or Kalman filtering that are already available in the onboard software.

In order to ease the joint work of DLR and Astrium, the prototype of TAFF has been written in Matlab language and integrated into a Simulink environment. The main reason for this choice is that the Matlab/Simulink environment can be used for both algorithm and

interface description and for the assessment of algorithm run-time performances.

Matlab language is indeed a powerful language which provides a lot of high level mathematical functionalities. Any equation can be very easily implemented using the embedded Matlab mathematical functions and vector/matrix handling. In addition, the visual representation of Simulink eases the description and the understanding of the interfaces. Once this top-level implementation is done, Simulink allows the automatic generation of ANSI C-code, enabling the possibility of rapid prototyping to assess the performances of the algorithm.

As illustrated in Figure 5, the prototype software is generated using Real Time Workshop Embedded Coder for an automatic translation of the Matlab/Simulink blocks into ANSI C code. The automatically generated C-code is then compiled using the Real-Time Executive for Multiprocessor Systems (RTEMS) cross-compiler system. Finally, the application is uploaded for preliminary validation and testing from the development host machine, a standard laptop PC, onto a representative flight processor.

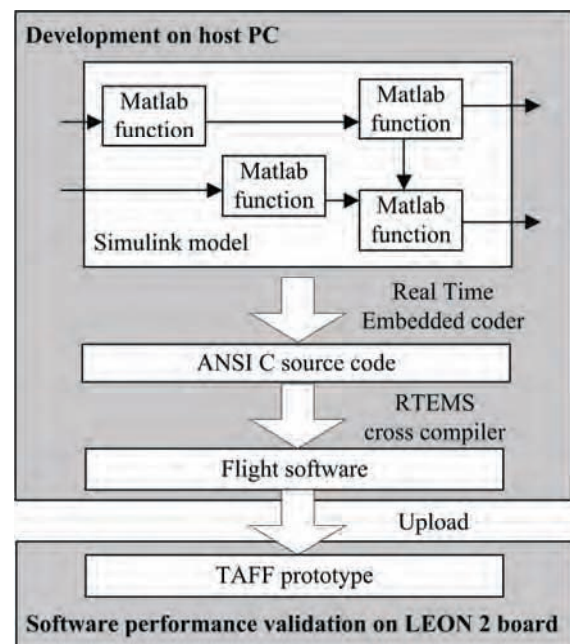

Figure 5. DLR's prototype software development environment for TAFF

The evaluation of the TAFF prototype flight software size and computational load has been performed at DLR on a LEON2 bare-board. The LEON2 microprocessor implements a 32-bit processor compliant with the SPARC V8 architecture which is particularly suited for

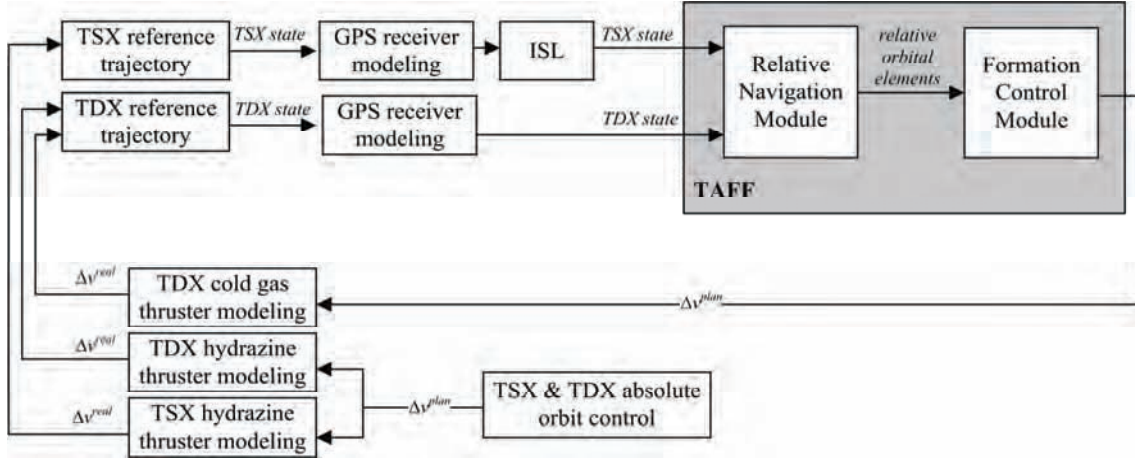

Figure 6. Simulation environment used for the performance assessment of TAFF

embedded applications. The processor is clocked at 40 MHz and is not equipped with a Floating Point Unit (FPU). Thus the emulation of floating point arithmetic is performed via software. Benchmarking tests performed on the LEON2 bare-board at DLR/GSOC and on the ERC32 TDX onboard computer at Astrium GmbH has shown similar performances in terms of software execution time.

4.2. Simulation Tools

Special care has been paid to the design of a simulation environment that is as realistic as possible. The position and velocity of the two spacecraft are computed by integrating numerically the equations of motions. A very accurate dynamical model has been used comprising the Earth gravity model GGM01S up to the degree of 30, the tidal perturbations, the luni-solar perturbations, the relativistic effects, the atmospheric drag (using the Jacchia atmospheric model) and the solar radiation pressure (using a classical cannon ball model).

The real states of the two satellites feed a GPS receiver emulator that simulates the output of the MosaicGNSS receiver onboard TSX and TDX. The realistic modeling of the GPS receivers represents a key point for the assessment of the TAFF performance.

The ISL transmits TSX GPS data and is simply modeled in order to introduce artificial data gaps depending on the relative separation and orientation of the spacecraft.

The GPS navigation solutions feed a Simulink model that implements the TAFF algorithm as delivered to Astrium. The maneuver commands generated by TAFF are then converted into an extended thrust with the inclusion of maneuver execution errors. The ground planned maneuvers are also modeled in order to study

the stability of the controller in the case of unexpected perturbations of the formation. To that end, a tangential maneuver of about 5 cm/s executed on both TSX and TDX is executed every two days during the simulation. The execution of maneuvers is affected by an uncertainty in the thrust size and an attitude orientation error. As shown in Table 1 different settings have been applied in the modeling of the cold gas and hydrazine propulsion systems.

Table 1: Modeling parameters of the actuators

	Propulsion system accuracy			
	η [%]	roll[°]	pitch [°]	yaw[°]
Cold gas thruster	3.0	0.0	0.0	1.0
Hydrazine thruster	2.0	0.0	0.0	0.0

The actually executed thrusts are finally incorporated by the real orbit propagators of TDX and TSX by a numerical integration over the burn time. The nominal configuration of the formation is set as follows in terms of relative orbital elements [m]:

$$\Delta a = 0 \quad a\Delta e = \begin{pmatrix} 0 \\ 300 \end{pmatrix} \quad a\Delta i = \begin{pmatrix} 0 \\ 500 \end{pmatrix} \quad a\Delta u = 65.$$

4.3. Test and Validation of TAFF

The qualification process for flight software development comprises verification and validation. The software verification process ensures that adequate specifications and inputs exist for any activity, and that the outputs of the activities are correct and consistent with the specifications and input.

The software validation process confirms that the requirements baseline functions and performances are correctly and completely implemented in the final product and that all design constraints are respected.

Tests are performed at different levels. At a software level, the prototype and its components are stimulated with a multitude of input data in order to cover all the possible software paths and verify the behavior during non-nominal situations. The ultimate goal is to verify the correct implementation of TAFF and the proper handling of errors. The navigation and control performance is assessed using the aforementioned simulation environment. On top of that, real MosaicGNSS in-flight data dumped from the TSX spacecraft (that is already in orbit) are planned to be used in order to replace the pure software modeling of the GPS receivers.

The full qualification and acceptance test cycle of the TAFF software once integrated into the TDX onboard computer will be performed at Astrium following the ECSS standards. Here the test environment will comprise a TDX Real Time Simulator (RTS) able to emulate the complete telemetry and telecommand interfaces. The RTS is applied for onboard software testing and acts as the onboard computer counterpart. More specifically, the RTS provides the onboard computer with sensor stimuli, load simulation and telecommand/telemetry signals.

5. PERFORMANCE ANALYSIS

5.1. Relative Navigation

The navigation errors depicted in Figure 7 are computed by subtracting the estimated relative position from the reference relative position.

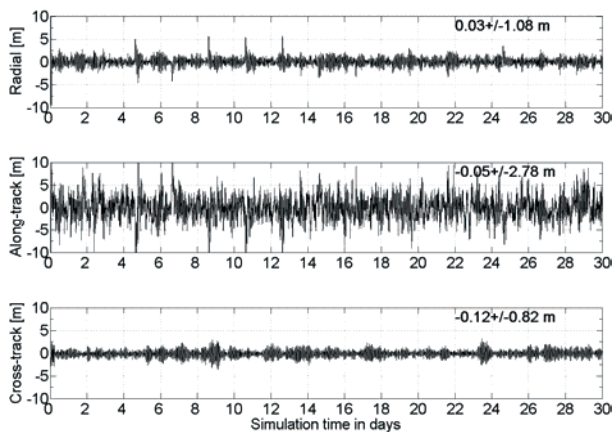

Figure 7. TAFF relative navigation errors in radial (top), along-track (middle) and cross-track (bottom) directions over 30 days.

Some spikes are clearly visible in the figure especially for the radial component of the relative position. These effects are caused by the erroneous a-priori information provided to the navigation filter at the instance of ground-commanded maneuvers. Even though the navigation accuracy is decreased, the filter is shown to

be robust enough to absorb these effects. Overall, the TAFF relative navigation accuracy is at the meter level.

5.2. Relative Orbit Control

The performance of the relative orbit control has been assessed by comparing the actual osculating relative motion produced by the reference orbit propagators with the desired osculating relative motion defined by the nominal relative orbital elements.

Table 2 summarizes the expected autonomous onboard control performances and compares them with simulation results using a ground-in-the-loop approach [5]. It is clear that TAFF is able to achieve much better performance in along-track direction than what can be achieved on ground.

This is simply due to the much shorter reaction time of the controller embedded in the TDX onboard computer. When maintaining the formation in a ground-in-the-loop scheme, Earth's oblateness, differential drag perturbations and maneuver execution errors can be corrected only after a 12-24 hours time interval. This delay affects mainly the along-track direction, since any small relative semi-major axis error induces a drift of the relative mean argument of latitude that is proportional to the elapsed time and ultimately to the maneuver cycle.

Table 2: Achieved control performance over 30 days using autonomous and ground-in-the-loop control

	Control performance [m]		
	radial	along-track	cross-track
TAFF	1.7	6.5	0.3
Ground-in-the loop	2.7	26	0.4

5.3. Software Run-Time Performance

In order to evaluate the computational load of the prototype flight software, a tailored simulation has been executed on the LEON2 board. The application is compiled as described in the section 4.1 and uploaded onto the board. The simulation covers a 15000 s data arc which corresponds to almost three orbital revolutions.

Due to the advanced optimization of the TAFF algorithm, the usage of resources is extremely limited. Figure 8 depicts the measured execution time of the prototype during the simulation. At the beginning of the simulation, only the Relative Navigation Module is activated. At time $t=10000$ s, the Formation Control Module is also activated, which increases slightly the computational load. Overall Figure 8 shows that the complete algorithm is executed in less than 40ms. Since the TAFF algorithm is called every 10s, the average run-time per second doesn't exceed 4ms. During the execution of the prototype, the allocated RAM has been evaluated to 50 kByte. As a consequence, the penalty on

the onboard software is below the specified limits (cf. section 3.1) and therefore acceptable.

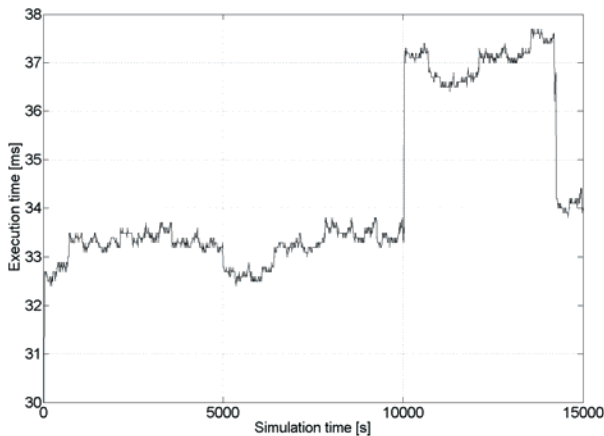

Figure 8. Measured execution time of the TAFF algorithm during 15000s

6. CONCLUSION

TDX will be equipped with an autonomous onboard relative control system. This has led to some adaptation of the design of the TDX onboard computer. As a major benefit, the resulting control performances of the TanDEM-X formation will be greatly improved and the operations done on ground will be at a long term considerably reduced. Tight requirements regarding the usage of the resources have driven the design of the software. A simple and robust concept has been developed that satisfies the software implementation constraints and provides a reliable and accurate relative control of the formation.

ACKNOWLEDGEMENTS

The TanDEM-X project is partly funded by the German Federal Ministry for Economics and Technology (Förderkenzeichen 50 EE 0601).

REFERENCES

- [1] A. Moreira et al., "TanDEM-X: A TerraSAR-X Add-on Satellite for Single-Pass SAR Interferometry", IGARSS, Anchorage, USA, 2004
- [2] D'Amico S et al., "Formation Flying Concept For Close Remote Sensing Satellites", AAS 05-156, 15th AAS/AISS Space Flight Dynamics, 11-15 Oct. 2003, Munich, Germany (2004)
- [3] G. Krieger et al., "TanDEM-X: A Satellite Formation for High Resolution SAR Interferometry". In: ESA Fringe Workshop, ESA Fringe Workshop, Frascati, Italy, 2005-11-28 - 2005-12-02
- [4] European Cooperation for Space Standardization; Space Engineering Software; ECSS--E--40A; 13 April (1999).

[5] J.S. Ardaens et al. : "Spaceborne Autonomous and Ground Based Relative Orbit Control for the TerraSAR-X/TanDEM-X Formation". 20th International Symposium on Space Flight Dynamics, Annapolis, 2007-09-24 - 2007-09-28

[6] D'Amico S., Montenbruck O.; "Proximity Operations of Formation-Flying Spacecraft Using an Eccentricity/Inclination Vector Separation", Journal of Guidance, Control, and Dynamics, Vol. 29, No. 3, May-June (2006).

[7] Clohessy W., Wiltshire R.; "Terminal Guidance Systems for Satellite Rendezvous", Journal of Aerospace Sciences, Vol. 27, pp. 653-658, (1960)