

Investigation of a high efficient Free Piston Linear Generator with variable Stroke and variable Compression Ratio

A new Approach for Free Piston Engines

Markus Graef*, Peter Treffinger**, Sven-Erik Pohl***, Frank Rinderknecht****

Chemical energy can be converted to electricity with very high efficiencies by means of a free piston linear generator allowing a variable stroke and a variable compression ratio. Therefore online-downsizing in part-load is possible by reducing the stroke. As a result throttling, wall and friction losses are reduced. The paper describes the concept of the free piston linear generator, which is well suited for the HCCI-combustion process. It is expected that emissions and the fuel-consumption can be noticeable reduced. Calculations based on the NEDC indicate significant fuel savings for a mid-class car. Because of the non-existing mechanical coupling, cylinder cut-off can be realized very easily reducing the consumption of high power cars especially in urban drive cycles.

The components linear generator and the gas spring have been built up and tested successfully. Examinations of the combustion process have begun on a fully variable electromagnetic valve-train test stand. A sophisticated adaptive control scheme is presented providing solid controls for the free-piston system. The paper describes the current status of the hardware development.

Keywords: Hybrid Electric Vehicles, Power Electronics, Modeling, Simulation

1. INTRODUCTION

The free piston linear generator (FPLG, Fig. 1) consists of the three main parts combustion chamber, linear generator with power electronics and a controllable gas spring. The expanding gas in the combustion chamber drives the rotor of a linear generator which produces electricity. The gas spring stores energy in terms of compressed air and returns the piston to its top dead centre.

Recent research projects in free piston motors generally use two combustion chambers. However, if the second chamber is changed into a gas spring then the bottom dead centre is no longer fixed and the variation of the stroke is possible, which is a very flexible and promising arrangement. Moreover, the weight of the linear engine can be reduced by generating energy even in the compression cycle of the combustion process. The FPLG varies the load point at constant frequency which allows to optimize the system by using the resonance vibrations of the gasses in order to maximize efficiency.

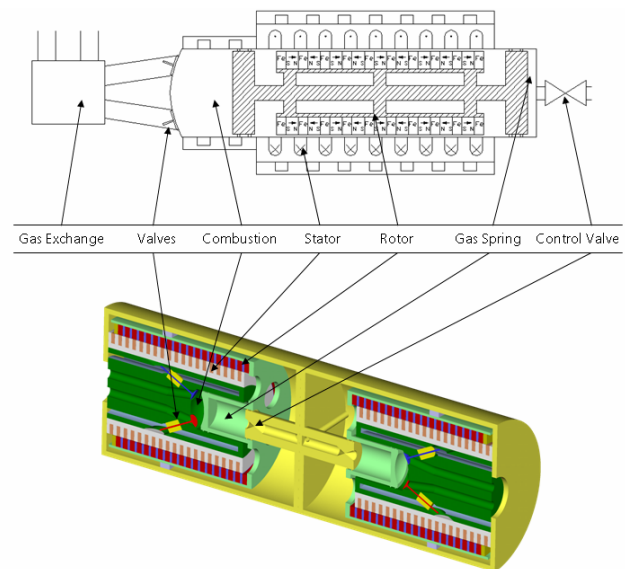

Fig. 1 Functional concept and two cylinder FPLG module

* German Aerospace Center, Institute of Vehicle Concepts, Pfaffenwaldring 38-40, markus.graef@dlr.de

** German Aerospace Center, Institute of Vehicle Concepts, Pfaffenwaldring 38-40, peter.treffinger@dlr.de

*** German Aerospace Center, Institute of Vehicle Concepts, Pfaffenwaldring 38-40, sven.pohl@dlr.de

**** German Aerospace Center, Institute of Vehicle Concepts, Pfaffenwaldring 38-40, frank.rinderknecht@dlr.de

2. COMBUSTION PROCESS

In the first phase of the project it was of general interest to explore the potentials of the free piston linear generator concept. Especially the advantages for the combustion process are of special interest since the combustion efficiency has great influence on the overall system performance. Therefore computer simulations are undertaken adopting conventional combustion analysis to the conditions of a free-piston system. The simulation code has to be very flexible since not a crankshaft angle defines the volume function of the cylinder but each part of the engine contributes to the piston motion and therefore influence the volume function. In cooperation with the FKFS¹ in Stuttgart a co-simulation has been setup showing promising results for the combustion process especially in part load conditions. There are several reasons for the improvement of the efficiency:

Variable Compression Ratio

The combustion can be affected through the variation of the combustion ratio. It is possible to enlarge the combustion ratio especially in the part load array where the phenomena of knocking does not limit it. As a result the efficiency becomes higher.

Variable Stroke

The variable stroke realizes an online-downsizing in part load conditions which yields in less friction losses because of the reduced length of the stroke. Second the wall losses are reduced because of the smaller surface for heat exchange with the surroundings.

Friction

There is no crankshaft in the system. The camshaft has been replaced by an efficient linear electromagnetic valve train. The piston has no side forces, so the friction can be reduced. And last but not least the system has only two combustion chambers which reduces the number of parts. Taking everything together friction losses can be significantly reduced.

3. LINEAR GENERATOR

A first prototype of a linear generator (Fig. 2) has been built on the bases of a permanent magnet synchronous linear machine. The machine is driven by a Semikron Semitrans SKM 300 GB 063 D. The DC link capacitor has a capacity of 50 mF for smoothing the current ripple resulting from the free wheeling phase and the pulsating power because of the non-continuous operation of a free piston system. The DC-link voltage is adjusted to 550 V at the test stand and will be reduced to 300 V in the final demonstrator. The rotor weighs round about 10 kg.



Fig. 2 Linear generator on the test stand

First measurements (Fig. 3) show a very good cooling efficiency of the stator, because a permanent force of almost 6 kN has been reached, whereas only 4 kN have been expected. The design with flat wires results in very good thermal conductivities with no hot spot in the windings. The water cooling of the aluminium housing has a good thermal contact to the electrical steel sheets, and the windings have only some 0.1 mm of distance to the electrical steel sheets. As a result the machine can be designed smaller by 33 % at the expense of the efficiency or it can stay the same with a force reserve for future applications.

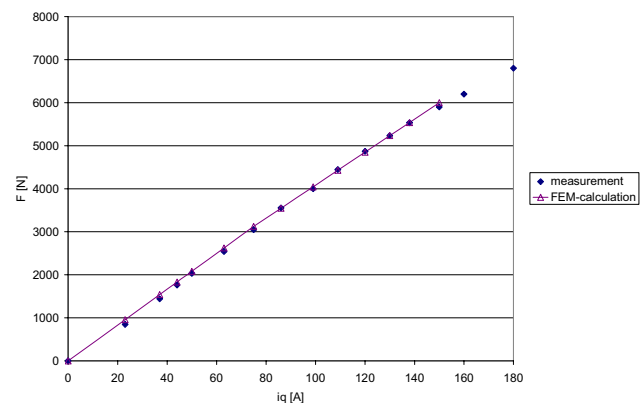

Fig. 3 Calculated and measured forces of the linear generator

4. GAS SPRING

The gas spring is a central control device adjusting the state of the FPLG system. To actively account for the changes in the combustion process following the engine demand the gas spring characteristics have to be adjusted in real time.

The first variant of a gas spring has been implemented on the basis of a BMW F 650 single cylinder engine (Fig. 4). The cylinder head is modified by an throttle-valve controlling the air mass in the cylinder. The crankshaft is driven by an electric motor, so that the whole system describes a gas spring. A pressure indication measures the cylinder pressure.

¹ Forschungsinstitut für Kraftfahrwesen und Fahrzeugmotoren Stuttgart

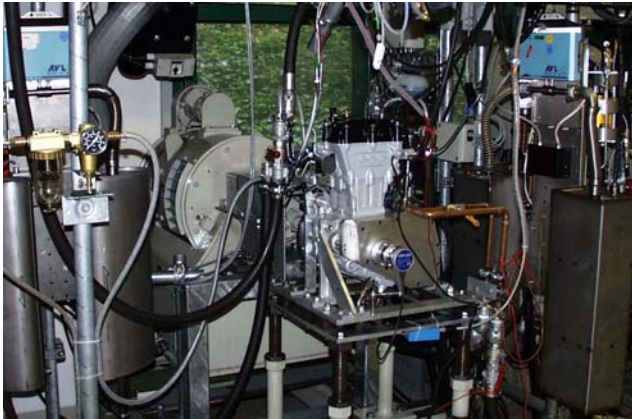

Fig. 4 F 650 engine on the test bench

Measurements have been made in respect of air mass resulting in different maximum cylinder pressures and rotational speed. With this arrangement it was possible to measure the wall- and blow-by-losses of the system. For the FPLG system the gas spring performance is of special interest. Main influence can be found in heat wall losses and blow-by mass flow. Further investigations covered the response time of the gas spring regarding system changes. The efficiency of the gas spring (Fig. 5) is defined by dividing the expansion energy through the compression energy.

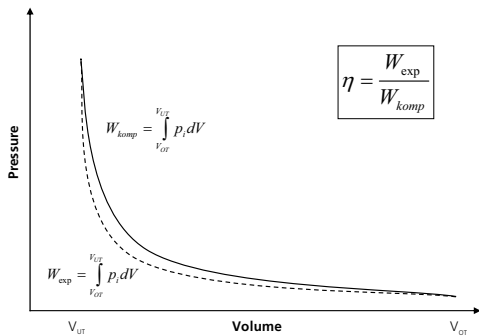

Fig. 5 Efficiency definition of the gas spring

The efficiency (Fig. 6) increases with the rotational speed confirmed by gas spring simulations because of reduced cycle time. The wall losses are nearly constant (constant maximum cylinder pressure) in respect to time such that the share of losses becomes smaller the faster the FPLG runs. About 10 % of the losses are due to cylinder blow-by, 90 % trace back to the wall heat losses (Fig. 7). As a result efficiencies greater than 95 % can be expected for a thermodynamically optimized gas spring.

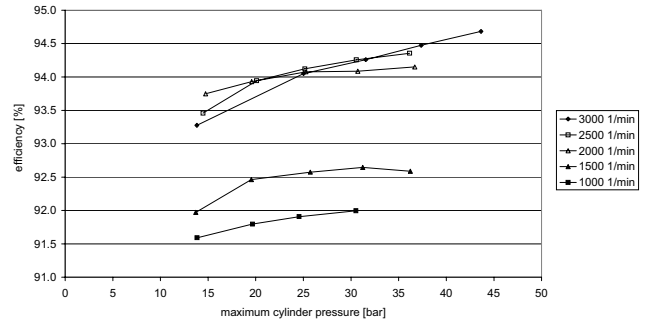

Fig. 6 Efficiency measurements of the gas spring

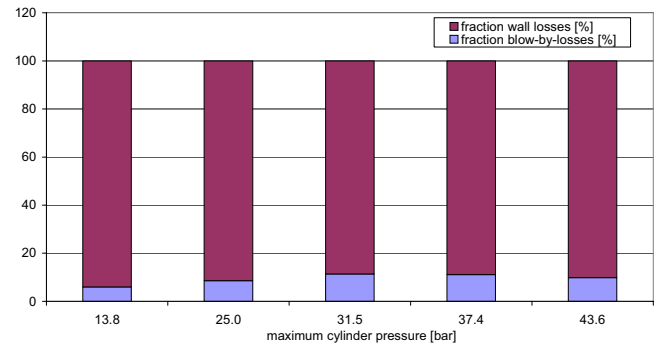

Fig. 7 Wall and blow-by losses at 3000 U/min

5. SYSTEM CONTROL

A major challenge of a free piston linear generator is the system control. The degrees of freedom

- variable stroke,
- variable compression ratio,
- variable piston motion
- variable valve timing and injector timing,
- variable exhaust turbo-supercharger pressure,
- variable generator force,
- and variable gas spring characteristics

allow for combustion optimization, but demand robust control for a safe operation.

The system control strategy consists of a piston motion control determining the generator force as well as an electronic valve an injector control defining the timing of the electromagnetic valves and the injector.

A supervisory control and optimization layer interacts with an estimator for the piston motion and calculates real-time thermodynamic equations for piston motion set points like the optimal stroke and the optimal compression ratio (Fig. 8).

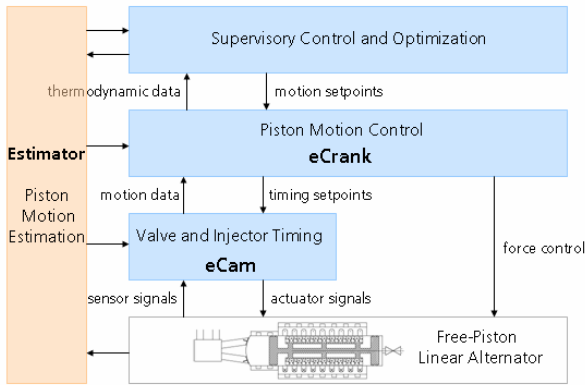

Fig. 8 Layer control scheme of the FPLG

The system control (Fig. 9) has been developed and tested in a object-oriented computer simulation using Modelica. The model represents all necessary hardware components, sensors and signals. The system model consists of the combustion process, a linear generator model and the gas spring. The partial models have been validated to measured data. The object-oriented component models and Modelicas advantages in multi-physical domains contribute to a understandable code such that parameter studies can be easily achieved. In the next year examinations will be made on this field to get more precise and adjusted models for the HCCI-process.

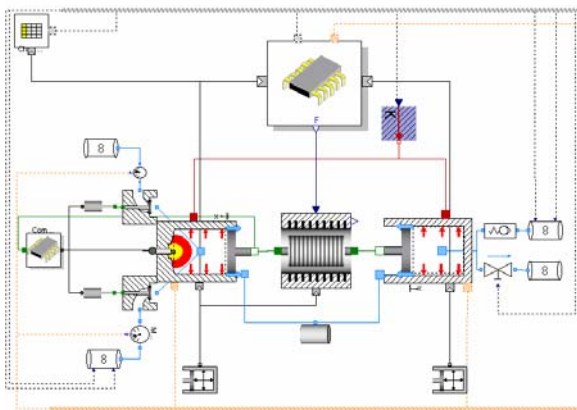

Fig. 9 Realized control scheme in Modelica

6. TARGET APPLICATIONS

The free piston linear generator can be used in many applications. Due to the expected high electrical efficiencies in the range of 46 % for a Diesel-HCCI-Process [1] the automotive application in the field of APU or even the main drive train is promising. A comparison (Fig. 10) has been made with different configurations on the basis of mid-class car with different installed power. Basis for the FPLG car is a 50 KW two cylinder module, which can be duplicated for the 100 kW and 150 kW variants. Therefore a real cylinder cut-off reduces clearly the consumption in comparison to the reference car.

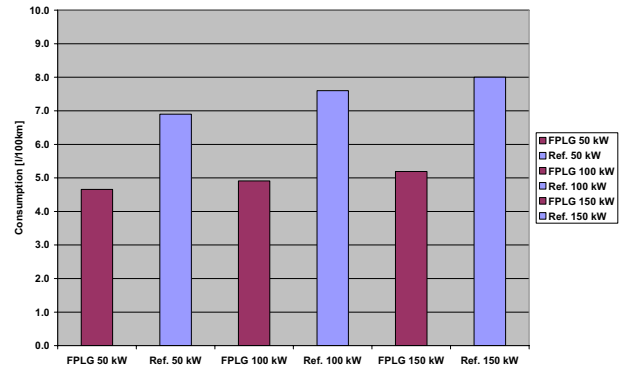

Fig. 10 Comparison of gasoline consumption

Besides the automotive applications the field of combined heat and power looks very promising. There the redundancy, when several modules are installed, is a great advantage for an operator of such a plant. In addition the flexfuel-capability of the system facilitates the handling with different qualities of natural gas which often pose a problem with knocking. Moreover the potential of natural gas often can not be used completely because of the missing standards for the cetane number so the combustion ratio has to be fixed on a lower level for security reasons.

7. RELIABILITY

The free piston linear generator can not have a system immanent reliability because of the non-existing crankshaft and camshaft. Therefore the electromagnetic valve train has to be observed in comparison to the piston movement. If there is a failure the valves have to be closed immediately. In case of a blackout the valves close automatically with the integrated springs. The piston system itself oscillates between the gas spring and the special formed combustion chamber which acts in the case of a blackout as a second gas spring. The path measurement system has to be installed redundant for safety reasons.

8. CONCLUSIONS

In this paper a brief introduction in the development process of a free piston linear generator has been given. The working principle was explained and research achievements have been shown. Computer modeling as well as hardware development have been lined out to show the potentials of this free piston system. The free piston linear generator is a compact power generating unit with system efficiencies up to 46 % [1]. Future work will be focused on hardware development and investigation of FPLG performance.

REFERENCES

- [1] Max Erland., FPEC, Free Piston Energy Converter, EVS 21 Monaco, 2005

BIOGRAPHIES



Markus Graef received the Master degree (Dipl.-Ing.) in Electrical Engineering from the Technical University of Munich, Germany, in 1998. After finishing his PhD (Dr.-Ing.) thesis in cooperation with BMW, Munich, he joined an engineering company for numerical simulations of electromagnetic fields. In 2001 he worked in a research project for high temperature fuel cells in cooperation with BMW and the German Aerospace Center. Since 2002 he is engaged in the institute of vehicle concepts of the German Aerospace Center in the field of electric drives and electric storage systems.



Peter Treffinger made his Masters Degree (Dipl.-Ing.) in chemical engineering at the University of Karlsruhe in 1988 and his PhD (Dr.-Ing.) in 1994. Dr. Treffinger has been responsible in several projects in the field of fuel cell systems and alternative power trains. He is project leader of the HyLite project and heads the department of alternative power trains.



Sven-Erik Pohl studied mechanical and chemical engineering at University of Hanover, Germany and at the University of Madison, Wisconsin, USA. He joined the DLR in 2003 working in the field of the free piston linear generator focusing on general system models and gas spring investigations.



Frank Rinderknecht made his Master Degree (Dipl.-Ing.) in electrical engineering at the University of Stuttgart, Germany, in 2001. F. Rinderknecht has been advised some projects in the domain of electrical drive and storage systems. In this project he is responsible for the linear generator.