

Research paper



SEDOS — A FAIR dataset for technologically-detailed modeling of Germany's energy transition

Hedda Gardian ^a, Hans Christian Gils ^{a,*}, Beneharo Reveron Baecker ^b,
Samuel Hasselwander ^c, Hendrik Huyskens ^d, Anik Islam ^e, Gian Müller ^{f,g},
Viktor Slednev ^h, Jonas Winkler ^e, Ulrich Fahl ^e

^a German Aerospace Center (DLR), Institute of Networked Energy Systems, Curierstr. 4, 70563 Stuttgart, Germany

^b Technical University of Munich, School of Engineering and Design, Department of Energy and Process Engineering, Chair of Renewable and Sustainable Energy Systems, Lichtenbergstr. 4a, 85748 Munich, Germany

^c German Aerospace Center (DLR), Institute of Vehicle Concepts, Pfaffenwaldring 38-40, 70569 Stuttgart, Germany

^d Reiner Lemoine Institute, Rudower Chaussee, 12489 Berlin, Germany

^e Institute of Energy Economics and Rational Energy Use, Heßbrühlstraße 49a, 70565 Stuttgart, Germany

^f Forschungszentrum Jülich GmbH, Institute of Climate and Energy Systems, Jülich Systems Analysis (ICE-2), Wilhelm-Johnen-Straße, 52425 Jülich, Germany

^g RWTH Aachen University, Chair for Fuel Cells, Faculty of Mechanical Engineering, Eilfschornsteinstraße 18, 52062 Aachen, Germany

^h Karlsruhe Institute of Technology (KIT), Institute for Industrial Production (IIP), Hertzstr. 16, 76187 Karlsruhe, Germany

ARTICLE INFO

Keywords:

energy systems modeling
sector coupling
open data
energy transition
FAIR
dataset

ABSTRACT

State-of-the-art modeling approaches for energy system planning reflect the interdependencies across demand sectors such as buildings, transport, and industry, the supply sector, and the transformation sector. However, modeling continues to be hindered by the fragmentation of data sources, inconsistent formats, and the extensive effort required for data acquisition and harmonization. To address these challenges, this paper presents the open dataset SEDOS, tailored for technologically-detailed modeling of the German energy system. SEDOS offers a comprehensive, structured, and up-to-date collection of data across all energy sectors, supporting cross-sectoral analyses. The dataset is based on a relational model structure that ensures consistency between technologies, commodities, and sectors, and is accessible through an interactive online dashboard. SEDOS includes scenario data up to the year 2070, hourly time series, and a detailed representation of more than 2000 technologies. On the demand side, the dataset records the development of energy services and products for the supply of which a broad technology portfolio is characterized in terms of its technical and economic parameters. While focused on Germany, the dataset incorporates a European perspective for the power sector to enable cross-border market assessments. A key novelty of SEDOS is its alignment with the FAIR principles (Findable, Accessible, Interoperable, Reusable), supporting transparency, reusability, and integration into diverse modeling frameworks, which lowers the entry barrier for modelers and facilitates consistent and reproducible energy system analyses. This paper outlines the methodology behind the dataset, presents its structure and contents, and describes instructions for use in long-term energy system planning and sector integration studies.

Abbreviations: BEV, Battery electric vehicle; CHP, Combined heat and power; CO₂, Carbon dioxide; FAIR, Findable, Accessible, Interoperable, Reusable; FCEV, Fuel cell electric vehicle; HFO, Heavy fuel oil; ICE, Internal combustion engine; LPG, Liquefied petroleum gas; Mt, Million tons; OEO, Open energy ontology; OEP, Open energy platform; PC, Passenger cars; PEM, Proton exchange membrane; PHEV, Plug-in electric vehicle; PJ, Petajoule; SOC, State-of-charge; SOEC, Solid oxide electrolyzer cell; V2G, Vehicle-to-grid; WACC, Weighted average cost of capital.

* Corresponding author.

E-mail address: hans-christian.gils@dlr.de (H.C. Gils).

<https://doi.org/10.1016/j.egy.2026.109390>

Received 10 November 2025; Received in revised form 26 March 2026; Accepted 9 May 2026

2352-4847/© 2026 The Author(s). Published by Elsevier Ltd. This is an open access article under the CC BY license (<http://creativecommons.org/licenses/by/4.0/>).

1. Introduction

1.1. Background

The transition towards a sustainable energy system is one of the biggest challenges of our time. Achieving this transformation requires comprehensive energy planning strategies that take technological, economic, behavioral, and political factors into account. Integrated modeling approaches play a crucial role in this process, as they enable the representation of the sector coupling (Fridgen et al., 2020) or sector integration, which describes the increasing links between energy carriers (e.g. electricity, heat or hydrogen), but also between various sectors (e.g. transformation, buildings, industry and transport). Understanding these cross-sectoral interactions is essential for identifying flexibility potentials, optimizing resource allocation, and evaluating the need for policy measures.

However, one of the key challenges in energy system modeling is the substantial effort required for data collection, harmonization, and validation. Energy system models rely on diverse datasets sourced from multiple domains, including technical specifications, economic parameters, demand projections, and resource constraints. Still, consistent and openly available datasets covering all these aspects are scarce. The lack of standardized data formats and the heterogeneity of available information further complicate the integration of different data sources.

1.2. State of research

Several open-source datasets exist that address parts of the data requirements in energy system modeling. Examples include Renewables.ninja, which provides time series for wind and solar generation based on weather reanalysis data (Staffell and Pfenninger, 2016), the Technology

Data Catalogues of the Danish Energy Agency, which offer techno-economic parameters for a broad range of energy technologies (Danish Energy Agency, 2025a), as well as datasets emerging from research projects such as TransHyDE (TransHyDE, 2024) and eXtremOS (eXtremOS, 2023). These resources are generally well-documented, openly accessible, and provided in usable, machine-readable formats. However, each of them covers only selected aspects of the broader data landscape—such as profiles, technology assumptions, or hydrogen infrastructure—and thus cannot by itself fulfill the comprehensive data needs of energy system models.

Only a few datasets provide the full range of data points required for the basic parameterization of an energy system model for Germany (see Table 1). This includes techno-economic, emission and capacity data for all commonly used technologies, resource data such as fuel potentials, temporal profiles for renewable energies and commodity prices, as well as demand data, including both load profiles and annual consumption values for multiple demand sectors and energy carriers. While this paper focuses on Germany, it should be noted that open datasets also exist for other regions, including the United States (NREL, 2025) as well as Brazil (Deng et al., 2023), and the global energy system (IEA, 2025; Brinkerink et al., 2024).

All identified datasets for Germany and Europe (Table 1) facilitate energy system modeling, yet each of them focuses on different aspects in terms of scope, resolution, and usability. The Open Power System Data (OPSD) platform (Hirth et al., 2019) offers well-documented historical data on electricity demand, generation, and installed capacity at national level in Europe, with high temporal resolution but limited sectoral scope. PyPSA-Eur (Hörsch et al., 2018) provides techno-economic assumptions and demand profiles for a broad set of sectors, including electricity, heat, transport, and industry. It features high spatial resolution but limited harmonization across sectors and technologies.

Table 1
Scope and characteristics of existing comprehensive datasets for energy system models.

name	publication year	content	format	spatial scope	sectoral scope	temporal scope	comment
open-ego (Müller et al., 2019)	2019	power plant capacity, demands, grid structure, techno-economic parameters, renewable energy production and demand profiles	SQL relational database	Germany (15 km ² , NUTS 3, 110 kV) + neighboring countries (NUTS-0)	power	historic base year (2015) + scenario years (2035, 2050), hourly resolution	high spatial resolution
eGo'n (Cußmann et al. 2024)	2023	power plant capacity, demands, grid structure (power/gas/ heat), techno-economic parameters, renewable energy production and demand profiles	SQL relational database, CSV, netCDF, HDF5	Germany (15 km ² , NUTS 3, 110 kV) + neighboring countries (NUTS-0)	power, gas, heat, transport	One year, hourly resolution / 2 scenarios: 2035 (after NEP 2035 v. 2021 Scenario C) and 2050 (100% renewable)	based on "open_eGo" and further developed in "reGo'n"
Open Power System Data (Hirth et al. 2019)	2020	power plant capacity, renewable energy production and demand profiles	CSV + metadata JSON	Europe (NUTS-0)	power	historic base years, hourly resolution	open format, metadata, uniform structure, documentation
PyPSA-DE (Lindner et al. 2025)	2025	techno-economic/ environmental parameter, capacity, demand, renewable energy profiles, potentials, prices	CSV	Germany NUTS-0 to < NUTS-2 + neighboring countries (NUTS-0)	power, heat, gas, industry, transport, agriculture	2020–2050 (5-year-steps), hourly resolution	Germany (NUTS-1) + 12 neighboring countries (NUTS-0)
PyPSA-Eur (Hörsch et al. 2018)	2019–2023	techno-economic/ environmental parameter, power plant capacity, demand, renewable energy profiles, potentials, prices	CSV	Europe (aggregation levels: NUTS0 to < NUTS2, sector-dependent)	power, gas, X2X, heat, industry, transport, agriculture	2020–2050 (10-year steps), hourly resolution	high spatial resolution, few conventions
RE-Europe (Jensen and Pinson, 2017)	2017	techno-economic/ environmental parameter, power plant capacity, demands, renewable energy profiles, prices	CSV + metadata	Europe (~50 km)	power	historic base years, hourly resolution	detailed historic representation of power sector, uniform format
TEMOA-Europe (Lerede et al., 2024)	2024	techno-economic/ environmental parameter, demands, renewable energy profiles, potentials, prices	SQL relational database	OECD Europe (single node)	power, heat, gas, industry, transport, agriculture	2005–2050 (5-year steps), 9 time slices	1000 technologies, no country focus or hourly profiles

RE-Europe (Jensen and Pinson, 2017) focuses on detailed historical representation of the power sector in hourly resolution and uniform format, but is limited in sectoral coverage. In contrast, the recently developed TEMOA-Europe (Lerede et al., 2024) database offers a very broad sectoral coverage including more than 1000 electricity, heat, gas, industry, transport, and agriculture technologies. However, it lacks a geographic focus, since it provides its data for one node in Europe and with an aggregated temporal structure (nine time slices per year), which limits its suitability for studies requiring hourly dynamics or country detail.

Specifically for the German energy system, PyPSA-DE (Lindner et al., 2025) and open-eGo (Cußmann et al., 2024) should be emphasized as open datasets. However, these are designed for the planning of grid infrastructures and for a high level of spatial granularity, respectively. Instead, these datasets offer no or only very limited possibilities of broadly optimizing the future use of different technologies in industry, buildings and the transport sector. A dataset allowing for this is not yet openly available.

1.3. Contribution

To close the identified gap in the available data for energy systems modeling for Germany, this paper introduces the SEDOS dataset, which allows technologically detailed modeling of the transformation of the German energy system. The name of the dataset corresponds to the acronym of the German name of the project in which it was compiled (SEDOS project team, 2025). SEDOS relies on a sophisticated model structure, introduced by (Reveron Baecker et al., 2024). The model structure and thus also the dataset presented here take into account the fact that the adoption of new technologies, in particular for the realization of sector coupling, plays a central role in the energy system transformation. This is reflected in the consideration of a broad technology portfolio.

A key aspect of the SEDOS dataset is its alignment with the FAIR principles (Wilkinson et al., 2016), ensuring that data is transparent, well-documented, easily accessible, and interoperable across different modeling frameworks and approaches. To achieve this, the dataset is hosted on the Open Energy Platform (OEP) (OEP, 2025) and registered in the Open Energy Databus (DBpedia Association, 2023), enabling structured metadata management, versioning, and open data sharing. Furthermore, SEDOS is designed with high-quality metadata, a consistent nomenclature of processes, parameters and commodities, and comprehensive ontological annotation, enabling interoperability across different frameworks. New ontological concepts were introduced to accurately capture the high level of detail in the processes. In addition, data adapters are provided as examples, facilitating straightforward integration by users.

In summary, the SEDOS dataset is intended to fill the identified gap in the availability of a FAIR compliant and technologically comprehensive dataset for the German energy system and its transformation until the year 2070.

1.4. Structure of the paper

The remaining paper is structured as follows. Section 2 describes the methodological procedure for creating and documenting the dataset. Building on this, Section 3 introduces the sectoral approaches and data description. Section 4 then explains the implementation of the FAIR principles in SEDOS. Finally, Section 5 highlights the added value, discusses the limitations and explores the potential uses of the dataset.

2. Method

The objective of SEDOS is more than the provision of a new dataset. In addition to the newly compiled dataset based on a uniform structure and a harmonized framework scenario, an ecosystem of supporting tools

was created to make the dataset easy to understand and use. Fig. 1 illustrates how the different elements complement each other in the overall workflow. In the following, the individual elements are being described in detail.

2.1. Definition of data scope and structure

The dataset is based on a model structure that organizes data in a relational manner and provides a reference framework for linking technologies, commodities, and sectors, as described in (Reveron Baecker et al., 2024, 2025). The dataset visualization dashboard (SEDOS, 2024a) helps users understand how individual technologies can be combined to form a complete model. Furthermore, it facilitates easy access to the dataset by highlighting commodity flows through the graphical representation of the model structure.

The scope of the dataset can be categorized into temporal, spatial, and technological dimensions. In the temporal dimension, the dataset provides an hourly resolution for all given profiles (8760-time steps), enabling high granularity in modeling short-term dynamics, flexibility, and system balancing. It includes nine scenario years in addition to the base year 2021, supporting long-term projections up to 2070. The scenario years have narrow intervals (3 years) in the near future and wider intervals in the distant future (10 years), thus reflecting data availability and uncertainty (see Fig. 2).

The spatial dimension represents Germany as a point model without explicit transmission technologies, simplifying spatial resolution while focusing on interactions between sectors. Still, the part of the dataset concerning the power sector allows for the analysis of cross-border electricity markets and international energy system interactions.

In the technological dimension, the dataset covers five main sectors: heat, industry, power, transport, and transformation (X2X) with more than 2000 individual technologies. The dataset also includes multiple aggregation levels, ensuring flexibility for different modeling applications and resolutions, that can be explored in the SEDOS dashboard (see example in Fig. 3).

The dataset is designed to meet the data requirements of a wide range of energy system models, enabling the investigation of diverse research questions. To determine the necessary data scope, the input data requirements of the modeling frameworks ETHOS.FINE (Klütz et al., 2025), oemof (Hilpert et al., 2018), and TIMES (Loulou et al., 2016) were analyzed as representative tools. This approach ensures a comprehensive and versatile dataset that can be utilized across different modeling frameworks.

Based on the requirements of the aforementioned modeling frameworks, the following parameters were identified as necessary for energy system modeling, determined and integrated into the SEDOS dataset:

- primary energy sources, such as hourly and annual availability as well as costs/prices for renewable energy sources and fossil fuels,
- techno-economic parameters, including amongst others investment and operational costs, efficiencies, installed capacities, death curves and expansion constraints,
- energy demand data,
- policy framework data, such as renewable energy targets and
- import and export information, including energy commodity prices, import restrictions, and cost-potential curves for Power-to-Gas (PtG) and Power-to-Liquid (PtL) products

Since the structure of data provision also depends on the specific modeling approach, modeling approaches were developed for which the SEDOS dataset can be applied. One example is the emissions accounting concept, which is described in the SEDOS documentation (SEDOS, 2024b).

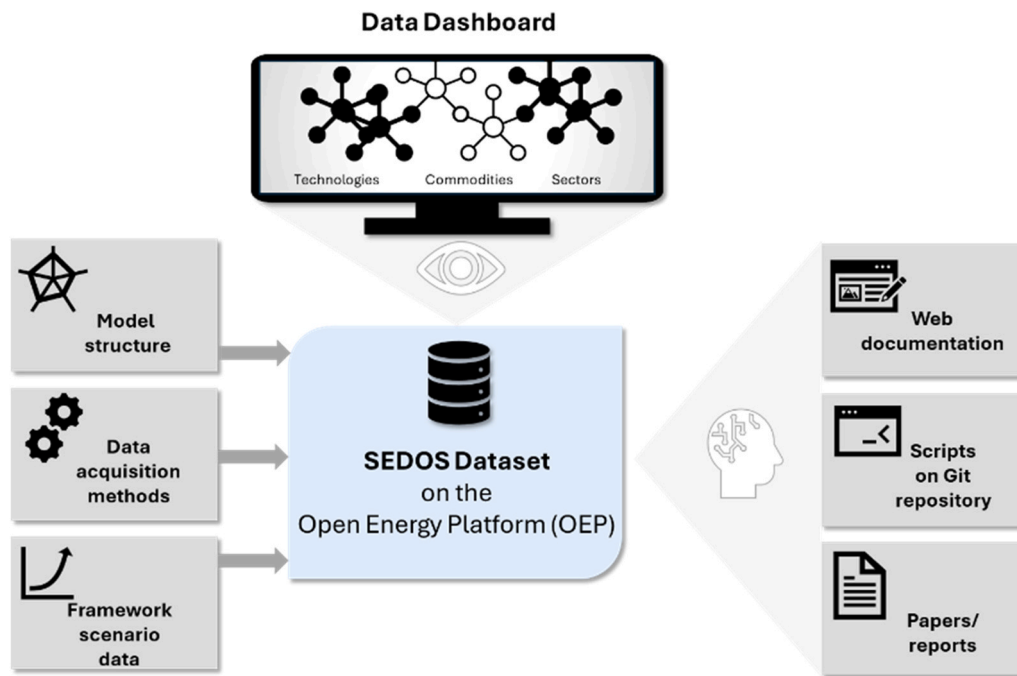

Fig. 1. Interrelations between the dataset, source data, and the supporting tools.

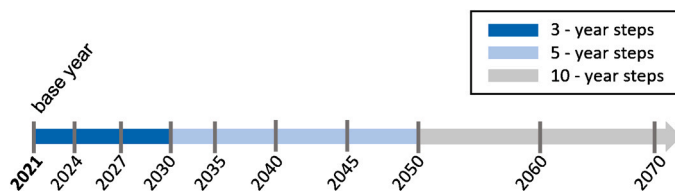

Fig. 2. Temporal resolution of the SEDOS dataset: 3-year intervals (dark blue), 5-year intervals (lightblue), 10-year intervals (gray).

2.2. Framework scenario data

The basis for modeling future energy systems are scenarios of the development of demand for energy services (such as the transport of people or goods, or heated living space). These are closely linked to overall economic and demographic developments. To create a uniform basis across all sectors contained in the dataset, various studies providing such framework scenarios were analyzed. To ensure that the data can be easily updated for future scenario analyses, particular attention was paid to the selection of publicly available and regularly maintained sources. Meeting these requirements, the current Projection Report 2024 for Germany (Mendelevitsch et al., 2024) was

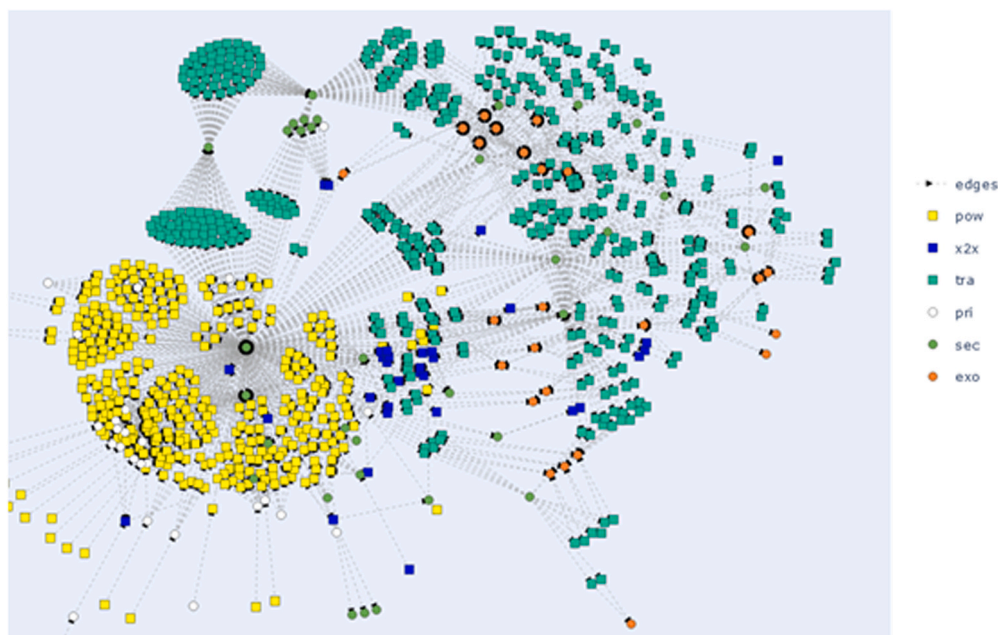

Fig. 3. Excerpt from the SEDOS model structure visualized in the SEDOS dashboard (Reveron Baecker et al., 2025).

eventually adopted for the framework scenario data.

To make the framework data usable for this work, two adjustment steps were necessary: 1) extension of the projection period from 2050 to 2070 and 2) completion of the information to match the demand data requirements. The adjustment step of extending the projection period was initially carried out for the central socio-demographic assumptions, e.g. gross domestic product (GDP) and population, then subsequently partly via specific variables, e.g. ton kilometers of freight transport per unit of GDP, for the aggregates and then via extrapolations of the shares in the structures, e.g. for the modal split. Missing demand variables are, for example, the deeper breakdowns in the transport sector or in the heat sector. For this purpose, sector-specific analyses from other sources were used.

Based on this, all required demand figures were available at the end of the process, essentially based on the work from the Projection Report 2024. This provides the basis for deriving the demand figures again when updates to the report in the same format become available.

Due to the lack of required detail in the framework scenario source, assumptions on the development of energy source prices must be based on an alternative source. Instead, the TYNDP 2024 (ENTSO-E, 2024) was identified as suitable for this purpose.

2.3. Parameter definition and data acquisition methods

The parameters utilized in the target energy modeling frameworks (2.1) were systematically collected and analyzed to identify the input parameter necessary for a comprehensive modeling approach. In addition to differences in parameter requirements across various frameworks, there are also variations in the scope arising from different modeling approaches. These variations depend on whether certain aspects of the system are represented in greater detail, which parameter are treated exogenously or optimized within the model run, and which processes, sectors, or dimensions are the primary focus, ultimately affecting the overall parameter requirements. The resulting SEDOS parameter set was designed to cover the requirements of a wide range of models, frameworks, and research questions as comprehensively as possible.

To populate the parameter set with data, a broad range of methods and data sources were employed, reflecting the diversity of data required for the overall dataset. The data originate from a combination of sources, including existing datasets, literature, expert judgments, and model-based estimations. While some data could be used directly, others required post-processing to meet the SEDOS requirements and ensure comprehensive coverage.

SEDOS manages conflicting external sources by applying a uniform preprocessing framework in which all incoming data are first converted to common units, spatial identifiers, and standardized technology categories. When external datasets use differing conventions, we perform transparent normalization steps, such as unit conversion, mapping of spatial codes to the national level, and alignment of technology definitions to a harmonized naming schema developed for SEDOS. These transformations remove inconsistencies while preserving the original meaning of the data.

2.4. Data management and usage

An open provision of the SEDOS dataset in alignment with the FAIR principles required standardized structures and a user-friendly infrastructure. Here, we introduce the data format, the data infrastructure and features to simplify the data usage.

2.4.1. Data format

The format developed for the SEDOS dataset can be broadly used to describe technologies across the different sectors. It consists of standardized columns containing general information (id, region, year, type, bandwidth_type, method, source, comment) and is complemented by

parameter columns, each describing a specific technology parameter (e.g. lifetime, mileage, WACC). By this approach, each table holds data for one type of technology, whereby each row represents an instance of this technology referring to a specific region and year.

Furthermore, a table can make use of the “type” column in order to distinguish between sub-technologies. The standardized columns “source”, “method”, and “comment” can be used to give row-wise information about the source of a value, the applied method to extract a value, as well as custom comments on a value. The column “bandwidth_type” indicates whether a parameter contains a single value or a range of values. As these standardized columns are represented as JSONs, each technology parameter in a data row can be addressed separately by using column name as key and related information as value.

Since there is only one region considered in the dataset, each row contains the relevant data for one scenario year. Each table is accompanied by metadata in the OMETADATA standard (Hülk et al., 2025) giving information about related sources, license, contributors, etc. as well as information on each column and related units. Special emphasis is placed on annotating the table columns within the metadata using the Open Energy Ontology (OEO) (Booshehri et al., 2021).

2.4.2. Data infrastructure

The SEDOS dataset is managed and structured using the OEP and the Open Energy Databus, ensuring efficient data organization and accessibility. The data is uploaded to the OEP alongside corresponding metadata. The metadata file is furthermore registered at the Open Energy Databus, a smart platform designed to structure, link, and manage energy-related datasets.

The Databus acts as a virtual bus that does not store data itself but instead provides metadata-based addressing and coordination of distributed data sources. It organizes datasets into structured collections and groups, improving discoverability and traceability. Through its knowledge graph approach, the Databus enables users to track data provenance, ensuring transparency and reliability in energy system modeling (Hoyer-Klick et al., 2023).

By integrating the SEDOS dataset into this infrastructure, data can be efficiently accessed, linked, and utilized for energy research and scenario analysis. This structured approach facilitates collaboration, supports automated data retrieval, and enhances consistency across different studies and models.

2.4.3. Usage support

In addition to utilizing the OEP and Open Energy Databus for data management, the SEDOS dataset comes with its own set of tools, all of which are stored and documented in a dedicated Git repository (SEDOS, 2024c). This repository contains the SEDOS online documentation, a dashboard, data adapters and automation scripts.

The SEDOS documentation is a comprehensive resource that provides detailed background information on the dataset structure and contents, workflows, and guidelines for working with the SEDOS data. It covers general information on the model structure, scenario definitions, and nomenclature, as well as technical specifications of the provided tools. Additionally, it includes instructions on data integration and usage, along with contribution guidelines for those who wish to expand or improve the dataset. By maintaining the documentation directly in Git, it remains version-controlled, transparent, and easily updatable by the community (SEDOS, 2024c).

A key component is the SEDOS dashboard, an interactive tool designed to facilitate the exploration and transparency of the dataset. The dashboard provides a user-friendly interface that allows users to examine the underlying model structure of the reference energy system through a network graph, offering a visual representation of the system's components and their interconnections. Additionally, the dashboard features an integrated table view, enabling users to explore the raw input data directly within the interface. One of the key functionalities of

the dashboard is the ability to analyze the aggregation steps defined in the model structure. Users can track how data is processed and structured at different levels of detail and download these aggregated datasets as needed. Furthermore, the dashboard supports the creation of charts based on potential model results, allowing users to compare outcomes across different modeling frameworks and scenarios while ensuring consistency in data usage. Thus, the dashboard offers visual insights into the available data, making it easier to understand and work with the dataset, even for users without extensive programming experience (SEDOS, 2024d).

Beyond the dashboard, the Git repository includes additional tools to support data usage. Three example adapters are provided for direct integration into the modeling frameworks FINE, oemof, and TIMES, enabling the structured import of SEDOS data into these tools. Furthermore, various automation scripts support the efficient upload and download of data, ensuring reproducibility and simplifying workflows.

3. Results

The parameters provided and the methods used for data collection and calculation are presented in the following. These are very heterogeneous in the individual sectors. Selected data points are also presented to illustrate the scope and structure of the dataset. The analysis highlights sector-specific examples that illustrate either the development of the data over time or the derivation of the values from their original sources. This approach provides additional context for understanding both the structure of the dataset and the underlying methodological decisions.

3.1. Power sector

To address the importance of local conditions and meteorological variability for the decentralized use of renewable energy, the power sector within the SEDOS dataset is first represented at a high level of technological, spatial (≥ 100 m resolution), and temporal (hourly) granularity. This initial parametrization covers all relevant electricity generation and remaining electricity consumption processes across Europe and follows the methodology established in (Slednev, 2024) and (Slednev et al., 2018).¹

In a second step, this highly resolved representation is systematically aggregated to support a flexible, single-node national modeling framework. This enables the application of the dataset in integrated, cross-sectoral German energy system models while preserving the necessary level of detail. A structured overview of the power processes, their aggregation logic and further methodological details are elaborated in (Reveron Baecker et al., 2024).

Besides, a further process aggregation of 9 potential classes for wind and solar, of 3 subsectors (ind, res, cts) for solar and battery and of resource or fuel classes (biomass and biogas) as well as of national electricity generation processes to country groups is implemented. For a specific biomass combustion process and for photovoltaics, this aggregation is exemplary illustrated in Fig. 4.

The initial parametrization relies on a broad range of open and high-resolution sources, including OpenStreetMap, the Danish Energy Agency (Danish Energy Agency, 2025a), the Global Energy Monitor (Global Energy Monitor, 2025), and the PEMMDB dataset from the TYNDP 2024 (ENTSO-E and ENTSG, 2024). A key focus is placed on the accurate representation of renewable generation potentials and profiles. For example, offshore wind modeling is based on a turbine park layout optimization at the individual turbine level, accounting for up to 16

turbine types at five hub heights. Capacity factors are derived from more than 15 years of historical weather data in hourly resolution and linked to spatially designated areas from national maritime spatial planning frameworks or real project locations.

To enable the integration of the power sector into a multi-sectoral, national-scale energy system model, the extensive set of site-specific and technology-specific processes is aggregated using a structured classification scheme. For wind and solar PV technologies, this involves aggregating existing generation profiles into single representative generation profiles for each considered scenario year. Potential-based generation is grouped into nine classes, differentiated by project development status (e.g. repowering, planned, greenfield) and levelized cost of electricity (LCOE), stratified by country and technology. Solar PV technologies are further disaggregated by sectoral application and building typology.

For conventional power generation technologies, particularly combustion-based systems, the challenge lies in the meaningful aggregation of a wide variety of process types. These vary in terms of fuel (e.g. fossil, biomass), technology (e.g. steam turbine, gas engine), and additional features (e.g. combined heat and power (CHP), carbon capture and storage (CCS)). Biomass-fired technologies are treated with a particularly high level of detail, as outlined in (Slednev, 2024). Investment options for future technologies are primarily based on techno-economic data from the Danish Energy Agency's catalogue.

Electricity consumption processes that are not explicitly assigned to other sectors (e.g. household appliances, tertiary sector devices) are derived as residual loads. These are calculated by subtracting the explicitly modeled sectoral demands from a high-resolution bottom-up electricity demand model, as described in (Slednev, 2024).

Lastly, to account for transmission system constraints in the single-node modeling approach, all power generation and consumption processes are characterized by their national affiliation and grid voltage level. This modeling approach allows for the representation of cross-border electricity exchanges and grid-level transitions (e.g. from low-voltage to extra-high voltage) through additional conversion processes, thereby maintaining consistency in energy flows even within a simplified spatial model. As illustrated in the following Fig. 5, this approach leads to a transmission grid connection of wind turbines (onshore and offshore), utility scaled battery systems, ground mounted photovoltaics, hydro power plants as well as all thermal power plants, with the corresponding production of a national central electricity commodity. For commercial and residential photovoltaic units and battery systems, furthermore, the self-production and storage of electricity on industry or distribution grid level is differentiated.

3.2. Transformation sector (X2X)

In SEDOS, the transformation sector covers electrolyzers, Fischer-Tropsch reactors and other fuel production technologies.² Besides electricity-based production, it entails further means of providing energy commodities, either through conventional processes based on fossil fuels or through relevant import routes to Germany.

Most of the processes in the sectoral dataset are subject to major uncertainties, as they relate to global markets or new technologies in the early stages of technological learning. For this reason, the dataset contains two different versions. The first version contains parameter ranges where applicable to reflect the uncertainty in the individual values. The second version contains only one selected value from the parameter range, which is chosen through interpolation or expert assessment.

The dataset characterizes all relevant commodity provision routes, starting from the import routes into the system and finishing with the

¹ A representative dataset for the power sector is provided by the process *biogas fueled CHP plant* in the region *Germany*, which is accessible at: https://openenergyplatform.org/database/tables/pow_combustion_cc_chp_biogas_de_1.

² An example of such a transformation-sector process (*solid oxide electrolysis cell*) can be accessed at the following link: https://openenergyplatform.org/database/tables/x2x_p2gas_soec_1.

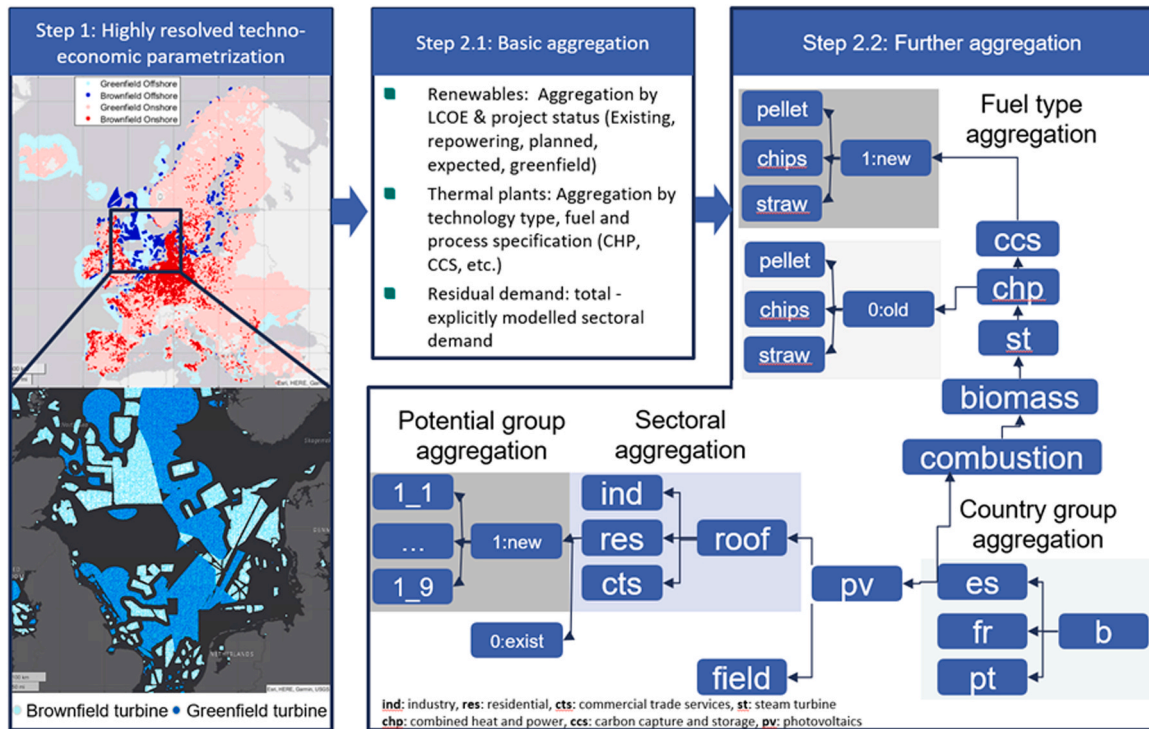

Fig. 4. Power sector parametrization and aggregation approach.

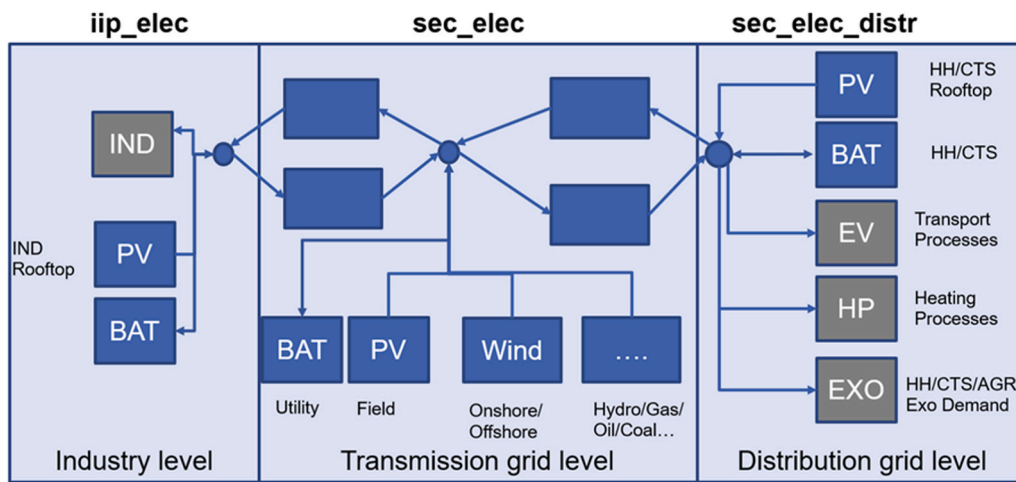

Fig. 5. Illustration of transmission grid consideration in a single-node model.

delivery of the commodities to other sectors. Import routes include crude oil, coal, uranium, different methane-containing commodities such as natural gas through pipelines or as liquefied natural gas, biogas and synthetic natural gas, synthetic fuels and renewable ammonia, methanol and hydrogen. Import processes are modeled such that the products can be imported for a fixed cost per unit. The data primarily stems from the scenario building guidelines of the TYNDP 2022 (ENTSO-E and ENTSOG, 2022) to maintain consistency between different commodity imports wherever possible. This data was complemented by (Agora *Verkehrswende et al.*, 2018) and (Brynnolf *et al.*, 2017) for synthetic fuels and (IRENA and Methanol Institute, 2021) for methanol and ammonia.

The imported commodities can either be directly delivered or further transformed into products that are requested by other sectors. For example, methane can be transformed to hydrogen through steam reforming or methane pyrolysis. These processes are modeled with

detailed techno-economic data that includes the conversion factors of the process, the investment cost, fixed and variable operational cost, lifetime and the weighted average cost of capital for selected years between 2021 and 2070. Additionally, existing capacities of a process were also taken into account and modeled separately. A key data resource for these processes was the report on technology data from (Danish Energy Agency, 2025b), however due to the variety of processes, a heterogeneous spread of publications was used to complete the dataset. Another example of imported commodities being transformed into value-added products are refineries, which are also modeled in detail. To account for the variable product distribution of refineries depending on the requested products, refineries – as well as Fischer-Tropsch synthesis – were modeled as multi-input multi-output processes with variable flow shares. Consequently, for every potential product, such as gasoline, diesel, liquefied petroleum gas (LPG) or heavy fuel oil (HFO), the minimum and maximum proportion of one product of the total distribution

were fixed. However, the implementation allows models to freely optimize the product distribution within these boundaries. Fuel consumption by the refinery itself was accounted for in the conversion factor of crude oil, similar to process emissions by the refinery. Table 2 demonstrates the flow shares of the different commodities for the refinery.

Data for biogeneous fuels such as biodiesel, bioethanol or biojet was modeled through variable production costs of the respective fuels coupled with a maximum potential. The maximum potential was calculated from biomass potentials of the respective crops that can be used for biofuel generation or from existing data on biofuel production in Germany.

As a subset of the technologies that were modeled in detail, Power-to-X technologies had a special focus due to the combination of their predicted high importance in a future German energy system and the uncertainty of the predictions regarding the techno-economic data. Therefore, for Power-to-X-technologies, a structured literature review of peer-reviewed articles was conducted (Müller et al., 2025). All the products in the transformation sector are subject to transport-related costs to the end-user. The transportation costs were modeled in dedicated processes and include a cost surplus per unit of transported good. Key data resources for these processes were (Soler, 2020) and (Feldpausch-Jaegers et al., 2016). Based on this data and using further assumptions on transportation distances, the variable cost contributions were derived and thus, the product provision to the demand sectors was established.

The transformation sector is characterized by the prevalence of emerging technologies with comparatively low technology readiness levels. Consequently, substantial cost reductions are anticipated as these technologies advance toward commercial maturity. These projected cost reductions have been explicitly incorporated into the dataset. Fig. 6 presents a representative excerpt, illustrating the projected cost dynamics and competitive landscape among various electrolyzer technologies. The data is derived from a comprehensive review of existing literature (Buttler and Spliethoff, 2017; Thema et al., 2019; Glenk and Reichelstein, 2019; Ancona et al., 2022; Reksten et al., 2022; dena, 2019; Parigi et al., 2019; Zauner et al., 2019; IEA, 2019; Zhou et al., 2022; Qi et al., 2021; Salomone et al., 2018; Wang et al., 2019; Schnuelle et al., 2019; Fasihi et al., 2016; Detz et al., 2018; Smolinka et al., 2018).

Fig. 6 compares investment cost projections for three electrolyzer technologies: PEM electrolysis, alkaline electrolysis and solid oxide electrolysis (SOEC). All technologies exhibit a downward cost trajectory over time, underscoring the anticipated influence of learning effects and economies of scale. Notably, the range of projected values across sources is substantial, even for short- to medium-term horizons, reflecting the high degree of uncertainty inherent in cost forecasting. This variability likely arises from divergent assumptions in the underlying studies such as differences in process design, electrolyzer scale, or boundary conditions, compounded by the fundamental uncertainty associated with projecting the evolution of immature technologies.

Fig. 6 also illustrates the evolving cost competitiveness of the examined technologies. While alkaline electrolysis currently appears to offer the lowest investment costs, this advantage is projected to shift in favor of PEM electrolysis by the early 2040 s, according to the exponential regression applied to the available data. In contrast, SOEC consistently exhibits significantly higher investment costs throughout the projection period, which could, however, be compensated by a superior electrical efficiency. Still, SOEC displays both the highest degree of cost uncertainty and the steepest projected cost decline. This pattern reflects its lower technology readiness level compared to PEM and alkaline technologies, implying greater potential for cost reductions as the technology matures. These findings highlight the dual nature of emerging technologies: while they entail significant uncertainty, they also offer considerable opportunity for technological and economic advancement.

3.3. Heat sector

The heating sector in SEDOS comprises of various heat generators and consumers.³ On the demand side, this is divided into residential and commercial buildings. The heat producers contain centralized and decentralized technologies. In industry, the technologies include auto-producers (CHPplants) that supply heat within a specific industrial branch, where it is subsequently used for various processes.

The building data of the commercial sector is categorized by building type (see Fig. 7) and is based on the ENOB database (IWU, 2021). In contrast, the data for the household sector differentiates buildings by size, construction year, and whether they are located in urban or rural areas. This data is sourced from (IWU, 2012). Heating technologies are generally classified into centralized and decentralized systems. Buildings equipped with centralized heating technologies are typically connected to a heating network supplied by a central heat producer.

The energy demand in the model is exogenously defined and calculated based on the current building stock and population. At the county level, population projections are derived from the Spatial Planning Forecast 2045 (Maretzke et al., 2024). Using these projections, the future building stock is estimated under the assumption that a certain amount of living space is required per capita. Changes in the building stock are then derived from historical trends at the federal state level.

The existing building stock is categorized by building type and construction period, with each combination assigned a specific heat demand value. Additionally, each federal state has an assumed rate of new building construction. By comparing projected new construction to the current stock, it is estimated how many buildings must be demolished or constructed to meet future demand. For the demolished buildings, assumptions are made regarding which building types and construction periods are removed in each time step. It is also assumed that the building stock undergoes a continuous renovation cycle over time. When components reach the end of their life cycle, they are expected to be replaced not just on an individual basis but with state-of-the-art solutions. For instance, if a single window fails, not only is that window replaced, but all windows in the building are upgraded. Moreover, the replacement typically involves modern solutions, such as triple-glazed windows, instead of the single-pane windows that represented the state of the art at the time of the building's construction. This process leads to a gradual reduction in heating demand across all building types over the analyzed period. As an example, Fig. 8 shows the decrease in heating demand for multi-household buildings constructed before 1979.

This detailed calculation of specific heat demand values for various building types and ages allows for the estimation of heating demand at the county level. Aggregating these figures across all federal states yields the total energy demand for the German building sector, differentiated by building type. Subsequently, this demand is further disaggregated according to the building age classes defined in the dataset, allowing for more accurate forecasting of future technology adoption due to the inclusion of building age as a determinant.

The heating demand in the model can be met by various types of heating technologies. These technologies are categorized based on the fuel they use and the type of building in which they are installed. Decentralized technologies use the input fuel directly to generate heat on-site for the building they serve. In contrast, technologies based on centralized heat supply receive heat as an input commodity, which is then converted into space heating or domestic hot water to meet the building's demand. The heat used by centralized systems is delivered via district heating networks, which connect heat producers with end consumers. Generally, the more consumers that are connected within a

³ An example of such a heat-sector process (*oil boiler*) can be accessed at the following link: https://openenergyplatform.org/database/tables/hea_hh_me1_existing_technologies.

Table 2
Data excerpt of maximum and minimum flow shares of different refinery products.

Product	Gasoline	Diesel	Kerosene	LPG	Naphtha	HFO	Refinery Gas
Minimum flow share	10%	23%	7%	2%	0%	0%	4%
Maximum flow share	35%	43%	23%	6%	7%	42%	5%

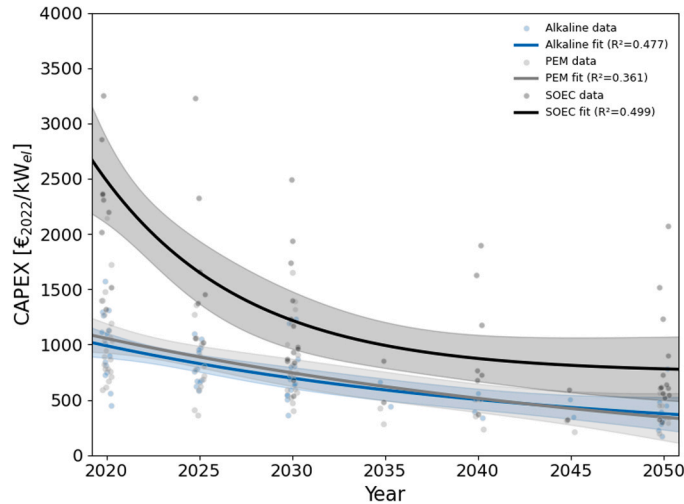

Fig. 6. Comparison of investment costs for three electrolyzer technologies: proton exchange membrane (PEM) electrolysis, alkaline electrolysis and solid oxide electrolysis (SOEC).

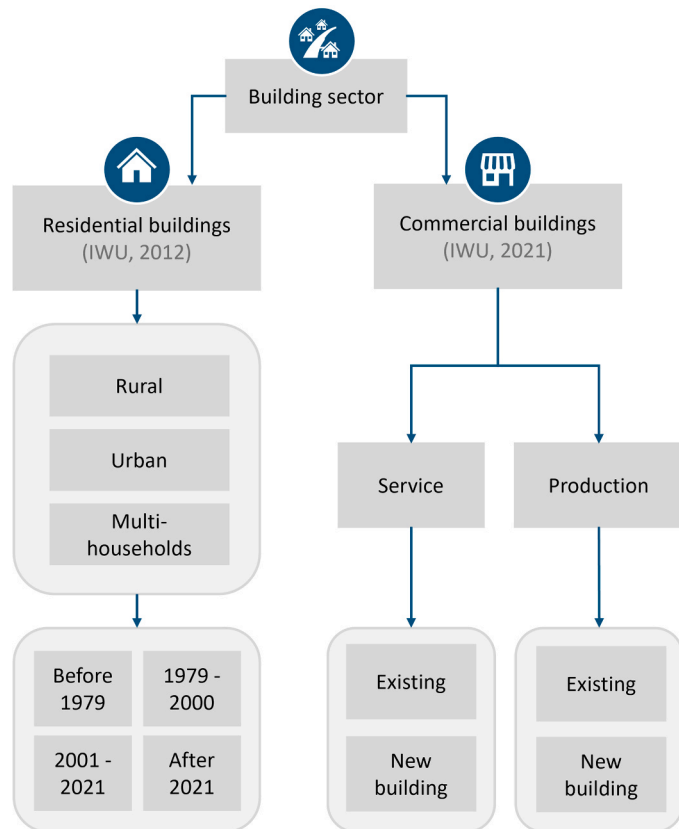

Fig. 7. Structure of the building sector separated into residential and commercial buildings. Further aggregation into building type and building age.

given area, the lower the per-unit distribution costs. To reflect this

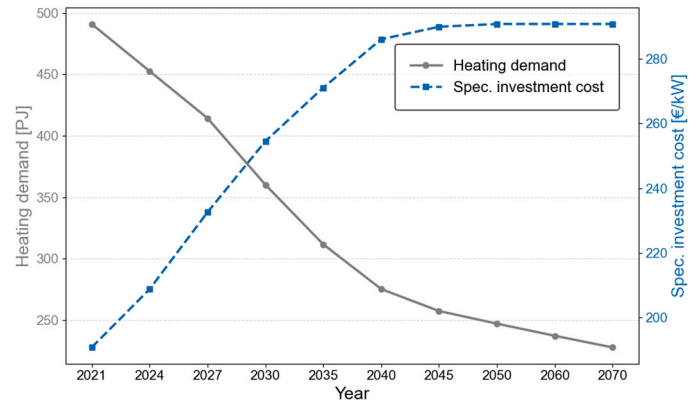

Fig. 8. Heating demand and specific investment costs of heating systems in multi-household buildings constructed before 1979. The left Y-axis shows the heating demand per building type in PJ, while the right Y-axis indicates the corresponding specific investment costs in €/kW. Both curves illustrate the effect of renovation and efficiency improvements over time.

effect, the network infrastructure is represented using different cost levels. In the SEDOS dataset, four types of heating grids are implemented: one represents the existing district heating infrastructure, while the other three represent newly built networks with increasing cost levels—the first being the least expensive, and the third being the costliest. Each cost level is assigned a specific potential, which is determined by analyzing the areas in Germany already connected to district heating and comparing based on population density and building types the remaining district types with the feasibility of the respective cost levels. This allows a model to select heating technologies based on the complete cost chain—from generation to distribution to end use.

Regardless of whether a technology is centralized or decentralized, investment costs in the SEDOS model are linked to their installed capacity. Empirical data show that specific investment costs rise as capacity decreases (KEA, 2024). Since less heating capacity is needed to meet household demand over time, the specific investment costs rise accordingly (increase in specific investment costs are illustrated in Fig. 8). To account for this, we developed regression curves for several technologies, based on price data from multiple manufacturers. Each curve is constructed using multiple capacity-cost data points, allowing for capacity-specific investment cost estimations (Brodecki, 2024). As a result, investment costs vary by building type and construction period, ensuring that technology choices are not only cost-optimized but also structurally consistent with the building stock characteristics.

3.4. Transport sector

The transport sector in the SEDOS dataset covers airplanes, city and long-distance buses as well as subways and trains, inland waterway vessels, passenger cars, motorized two-wheelers, trucks, and vehicles used in construction and agriculture. It not only includes the standard transport parameters but also provides additional data necessary for the endogenous optimization of fleet expansion. This enables the derivation of an optimal fuel and drivetrain mix. To prevent unrealistic fleet compositions—since the choice of vehicle drivetrain and fuel type is a highly subjective decision—fleet expansion is constrained by market shares for each vehicle type. The modal split, i.e. the distribution of

demand across vehicle types (small cars, buses, trains, etc.), is specified in exogenous demand parameters.

This results in a SEDOS transport dataset that includes the following parameter:

- **economic:** investment cost, fix/variable operation and maintenance cost, weighted average cost of capital (WACC)
- **technical:** tonnage, occupancy rate, lifetime, mileage, efficiency, emission factor
- **demand:** annual demand for transport service (in pkm or tkm), demand profile
- **fleet stock:** number of vehicles in stock and death curve
- **fleet composition:** market share range

This data is provided for each vehicle type to parameterize a simplified modeling approach (see upper section “fueling VOG” of Fig. 9).⁴ This means that these vehicles have a fixed, exogenously specified driving profile and the fuel tank is not considered as a possible buffer between fuel energy demand and the provision of driving power. In contrast to battery electric vehicles (BEV), the refueling process is evened out across the fleet and takes place during the driving process rather than being decoupled during parking times. In addition, the fuel supply chain is seen as having a high storage capacity that is not available in the electricity grid in the same form, which is why further data for a detailed consideration of batteries and the charging process is provided for BEV.

In contrast to the described basic vehicle dataset with limited optimization possibilities (only composition), the dataset can also be used to explicitly model an internal battery and the decoupling of refueling and driving with a flexible modeling approach for a more realistic representation of the actual conditions of BEV. Furthermore, this dataset extension enables the modeling of grid balancing services, as the charging operation can be optimized model endogenously in a system-friendly way, using the stored energy dynamically based on the system requirements.

The data for the detailed modeling of BEV allows the vehicle fleet to be divided into three categories, which represent the charging modes shown in Fig. 9: (VOG) user-controlled, inflexible charging without the possibility of optimization, (V1G) system-controlled, flexible charging and (V2G) system-controlled charging with the possibility of feeding energy back into the grid. The proportions of these categories are specified exogenously.

The additional parameters of the extended dataset include:

- **wall box:** stock, invest cost, capacity, availability profiles, charging losses
- **battery:** capacity, stock, self-discharge losses, charging/discharging losses, maximum/minimum state-of-charge (SOC) profiles
- **additional:** share of charging modes

By incorporating both modeling approaches (basic and flexible) into the SEDOS dataset, it can be used to model potential flexibilities in the transport sector, while limiting the model size when complex modeling offers few advantages.

Scalar data describing vehicle characteristics, energy consumption, and operational parameters primarily originate from literature reviews, own calculations, and well-founded assumptions. Vehicle data for passenger road transport is derived from a combined analysis of available vehicle models in Germany using the vehicle database of the General German Automobile Club (ADAC, 2024) as well as the Future Fuels study (FVV, 2021). This database encompasses data from over 42.000

⁴ To illustrate the underlying data structure, an exemplary process for the simplified vehicle representation is provided at: https://openenergyplatform.org/database/tables/tra_road_mcar_ice_pass_gasoline_0.

vehicle models that have been available since 2016, including their technical specifications and list prices. Allowing for precise trend analyses for different vehicle powertrains. Fig. 10 exemplarily shows the analysis of vehicle data for battery electric vehicle models available from 2016 to 2024. The results indicate that battery capacity and vehicle range are continuously increasing. However, it also becomes apparent that these parameters are approaching a limit. Considering the limited space available in vehicles, this is understandable, as the battery size cannot be increased indefinitely. For the SEDOS dataset, it is therefore assumed that the battery capacity of BEVs will only increase until 2030 and remain constant thereafter. For the medium-class segment, this means an increase from 59 kWh for new vehicles in the year 2020 to 70 kWh for new vehicles in 2030. Likewise, this also applies for the other vehicle categories.

The average specific vehicle stock parameters were calculated as a weighted mean of the national vehicle fleet using registration data (KBA, 2021), combined with detailed vehicle information from (ADAC, 2024). Merging was performed based on manufacturer and vehicle type numbers, which uniquely identify each vehicle model, including distinctions between powertrain configurations and battery capacities. The analysis reveals that the average battery capacity of medium-class vehicles in the existing fleet is around 48 kWh, which remains substantially lower than the average battery capacity observed in newly registered vehicles.

This scalar data is enriched by the provision of hourly profiles of energy demand and vehicle charging flexibility. To obtain these, different methodologies are applied depending on the mode of transport. For example, train driving profiles are derived from timetable evaluations, while individual road vehicle profiles are computed using the open-source tool *venco.py* (Miorelli et al., 2024). This tool generates driving profiles and flexibility profiles for electric mobility, based on data from the surveys “Mobility in Germany” (MiD, 2017) and “Kraftfahrzeugverkehr in Deutschland” (KBA, 2012). By incorporating these detailed datasets and methodologies, the transport sector representation in SEDOS enables a nuanced analysis of mobility patterns, energy demands, and potential flexibility options for energy system modeling.

3.5. Industry sector

In SEDOS, the industry sector has been divided into 11 primary branches based on the NACE (European Commission, 2025) classification of industry activities. Seven of these branches—automotive, cement, chemicals, glass and ceramics, iron and steel, non-ferrous metals, and paper—have been modeled in detail, with production volumes representing their demand.⁵ The remaining four branches — food and tobacco, rubber and plastics, metalworking, and machinery equipment — are included in the dataset in a simplified form, with energy service demand conveying their respective demand.

A detailed set of processes for the provision of energy services such as process heat, steam, lighting, machine drive, cooling, and air compression is introduced, as well as a comprehensive technology set for the process chains of each subsector to fulfill the exogenous production volumes. This implies that the required techno-economic data is prepared considering the output of each process in the process chain. Techno-economic data includes process conversion factor, lifetime, investment cost, emission factor, and fixed and variable operation costs. A wide range of innovative technologies have been described alongside conventional technologies and their existing capacities. Notably, a linear decrease in these existing capacities is assumed, such that further investment in either conventional or innovative technologies can take place. One of the key components of the industry dataset is having two different CO₂ emission types, unlike other sectors: process emissions

⁵ An example of such a detailed process can be found here: https://openenergyplatform.org/database/tables/ind_steel_blafu_1.

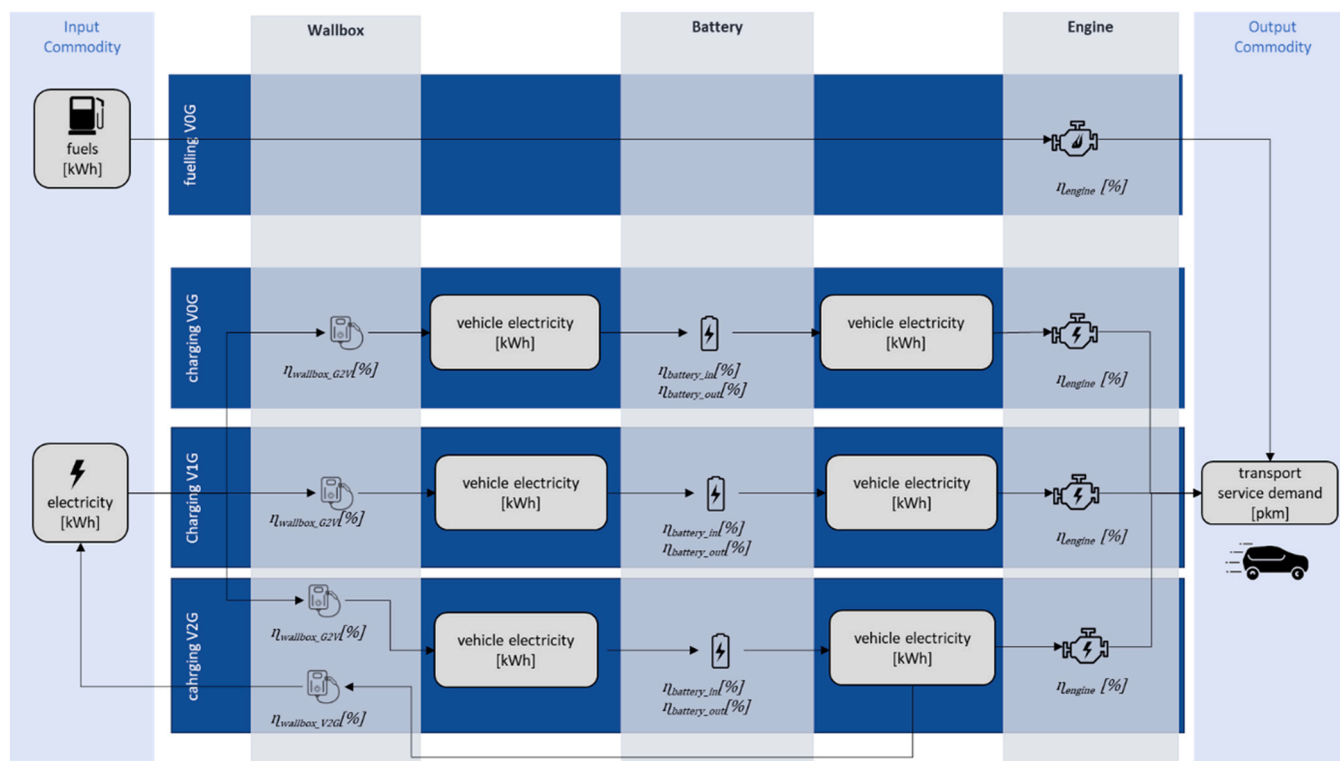

Fig. 9. Modeling schema as the basis for the data scope of the dataset for vehicles with for fuel-based vehicles as well as BEV with inflexible and flexible charging. Illustrating the interaction between the wall box component, the battery, and the engine, along with the energy flows and the reverse electricity flow back to the grid in the form of Vehicle-to-Grid (V2G) functionality.

related solely to the individual process and combustion emissions generated from the combustion of fuels. Combustion emissions are usually input-specific and process emissions are related to output. Due to their heterogenous structure, the approaches used to determine the datasets for the different subsectors vary. The approaches used for the automobile and chemical industries are described below, showcasing this diversity.

3.5.1. Automotive industry

The significant changes in the future transport sector necessitate a detailed depiction of vehicle production processes. In the SEDOS dataset, automobiles are categorized based on usage (passenger cars, light and heavy commercial vehicles) and drive types (internal combustion engine (ICE), plug-in electric hybrid vehicle (PHEV), BEV, fuel cell electric vehicle (FCEV)). Production volumes are provided as exogenous demand in million units.

The dataset aggregates complex production chains of the automobile industry into parts production, battery production, painting, and assembly processes (see Fig. 11). Life cycled approach based GREET2 model (Argonne National Laboratory, 2022) alongside various other sources is used to generate the parts production data. Annual production volumes for the future are calculated based on (BMW, 2019) and vehicle fleet expansion in the transport sector from (Ariadne, 2021).

The energy consumption per unit vehicle production varies significantly not only depending on vehicle types, size, and weight but also on the considered composition of materials, complex value chains, and energy efficiency of complex production processes. Different approaches have been used to estimate the energy consumption of vehicle production, such as mass-based algorithms, life-cycle inventory, material flow approaches, the Vehicle Manufacturing and Assembly (VMA) model, etc.

Fig. 12 displays the energy required to produce specific types of passenger vehicles according to SEDOS data, along with energy consumption values found in various literature sources for ICE passenger

cars (PC) averaging at 19,2 GJ.

The calculated energy consumption data of vehicle production is highly dependent on vehicle weight and material composition. The considered vehicle weights used are 1190 kg (PC, ICE), 1480 kg (PC, PHEV), 1430 kg (PC, BEV), and 1390 kg (PC, FCEV) based on (Jungmeier et al., 2019). The lower energy consumption values in the SEDOS dataset compared to the literature values can be attributed to the usage of updated data with increased energy efficiency of different vehicle production processes as well as different material compositions.

3.5.2. Chemical industry

Low-carbon or green energy alone will not be sufficient to meet climate neutrality in the chemical industry without substituting fossil feedstock. Therefore, a comprehensive approach is introduced that not only includes energy flow but also feedstock flow. The SEDOS chemical industry dataset covers data on basic chemicals (chlorine, ammonia, methanol, olefins, and aromatics) with exogenous demand in million tons (Mt), and energy service demand for other chemicals in petajoules (PJ). The flow of energy and feedstock into processes to produce chemicals is distinguished and integrated where it is significant. This means that feedstock flows are separately integrated not only for carbon-containing fossil feedstocks (e.g. natural gas, naphtha, heavy fuel oil) but also for alternative low-carbon or green feedstocks (e.g. hydrogen from electrolysis, green methanol). The use of captured carbon dioxide (CO₂) as feedstock is also enabled by carbon-capture technologies, and the captured CO₂ can be utilized as feedstock through the delivery process.

Relevant technologies have been developed to produce hydrogen, which can be used as a feedstock in the chemical industry to produce ammonia and methanol. Notably, hydrogen commodities for methanol production vary depending on whether hydrogen is generated from fossil feedstock (natural gas, heavy fuel oil), biomass, or hydrogen produced from electrolysis. Subsequently, two different methanol

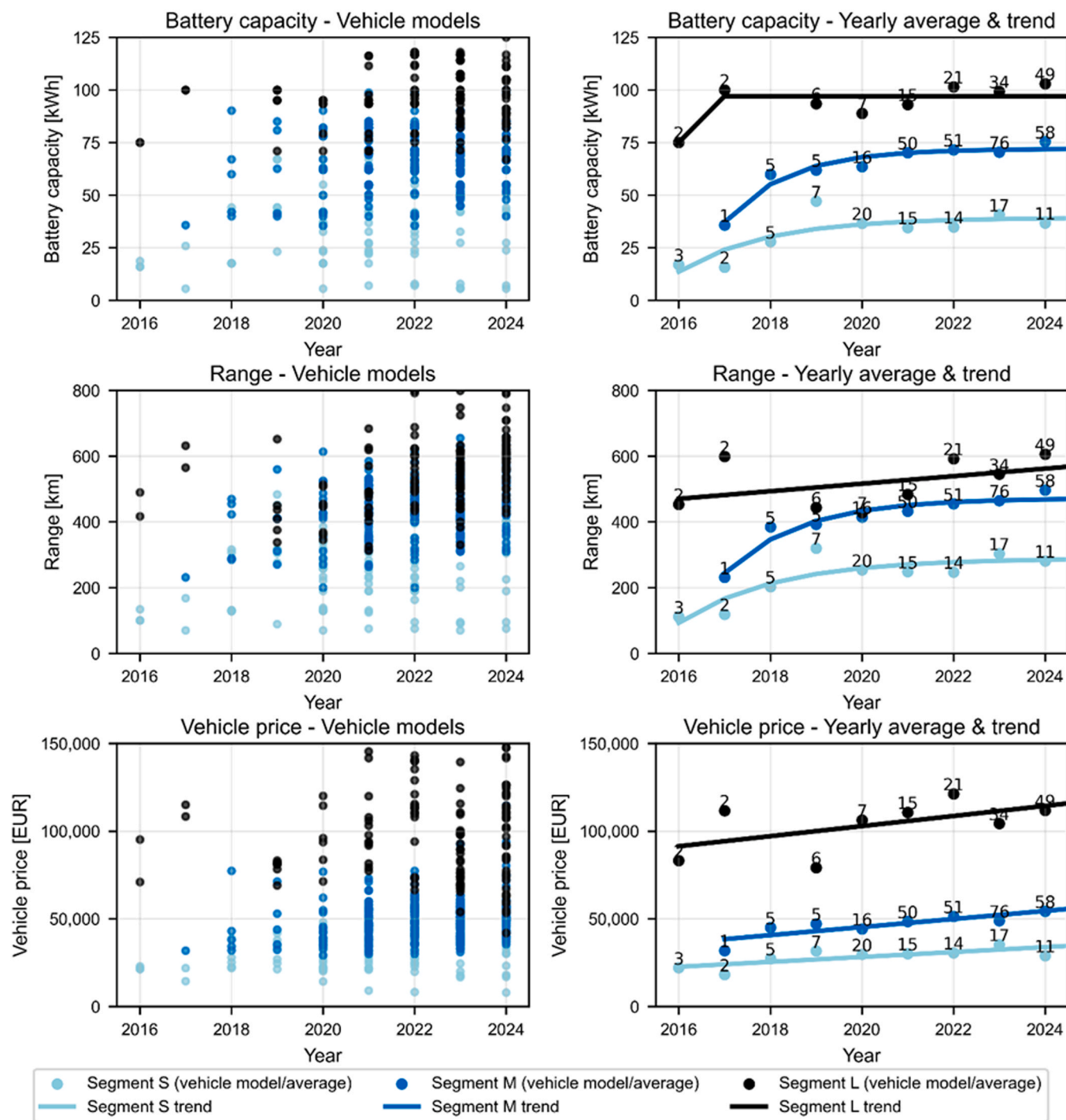

Fig. 10. Left: Technical specifications of distinct battery electric vehicle models available in Germany (2016–2024) grouped by vehicle segment. Right: Annual averages, with numbers above each point indicating the number of models included for that year and regression-based projected trends. Own analysis based on (ADAC, 2024).

commodities are introduced: one representing exogenous methanol demand and another that can be used further in the transport sector as fuel, as well as in chemical industry as feedstock for methanol-to-X (olefins, aromatics, gasoline and kerosene) processes. High-value chemical production processes can be differentiated to satisfy exogenous demand for aromatics and olefins. While (Mendelevitsch et al., 2024) is used directly as source of the exogenous demands (Mt) for basic chemicals, it is enriched with own calculations are used to establish the demand (PJ) for the rest of the chemical industry. Further sources include (Danish Energy Agency, 2025a; Nijs and Ruiz, 2019; Bazzanella

and Ausfelder, 2017; Geres et al., 2019; and Soler et al., 2022). Processes and energy service commodities- steam, process heat, other processes, electro-chemicals, and machine drive- are introduced accordingly to meet the exogenous energy service demand of the rest of the chemical industry.

4. Implementation of the FAIR principles

The SEDOS dataset resulting from the work presented here is developed and published using a FAIR implementation profile, enabled

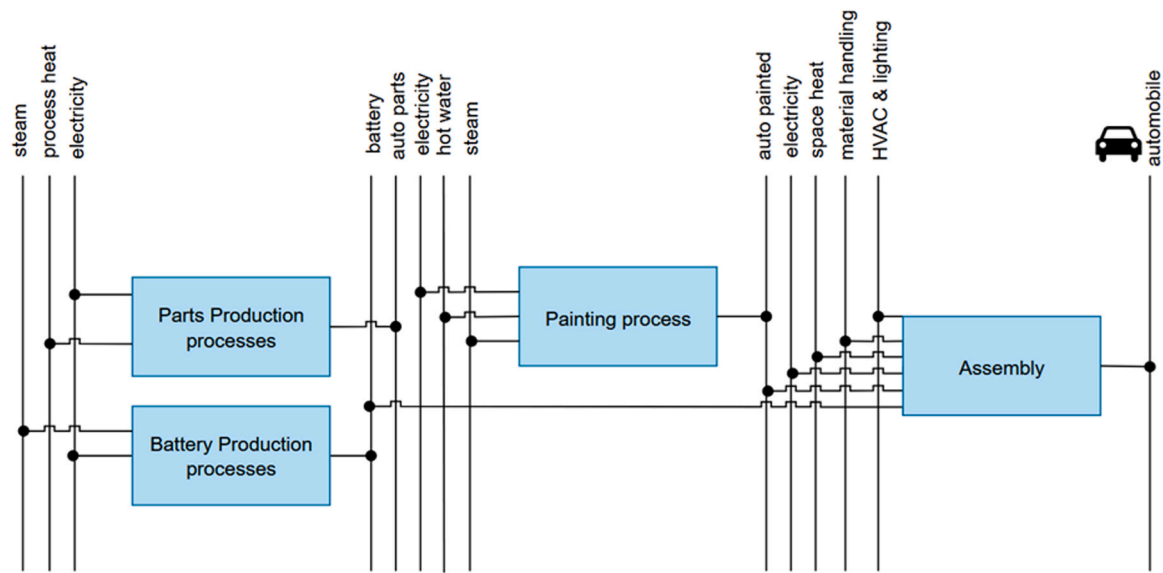

Fig. 11. Simplified model structure of automobile production processes, illustrating the considered core steps of data preparation.

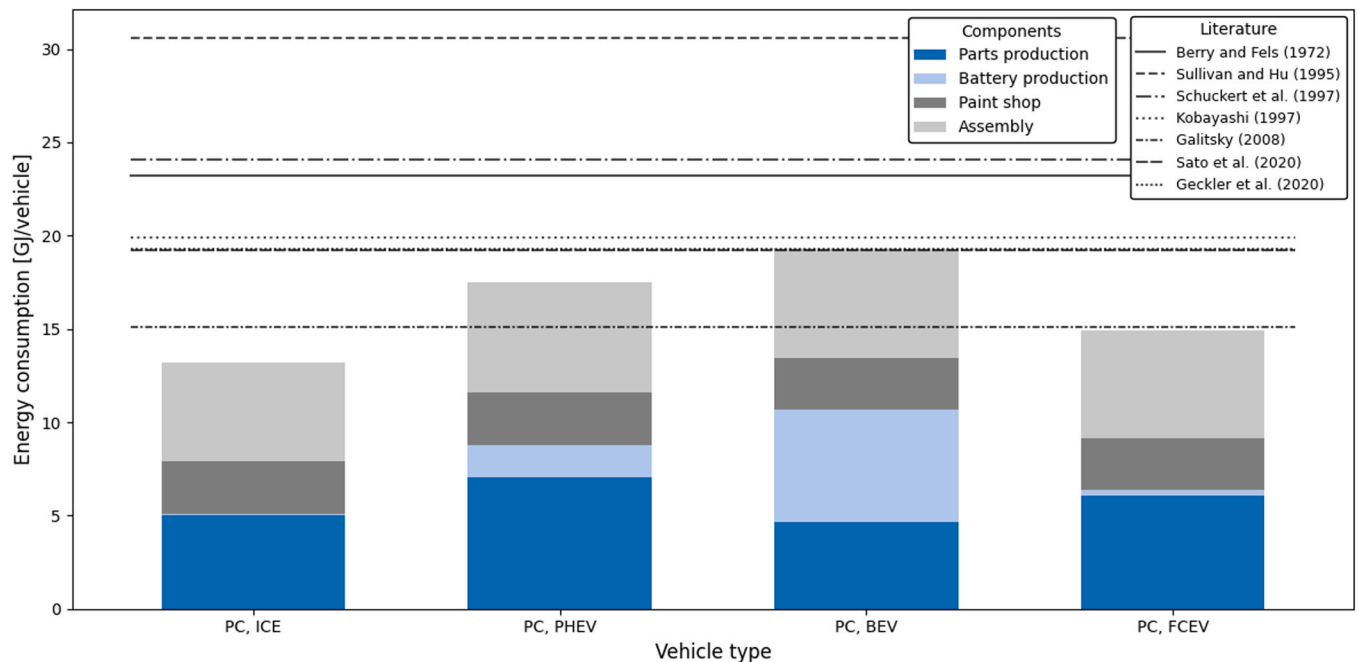

Fig. 12. Energy consumption values per vehicle produced in SEDOS dataset and found in literature. Lines represent the literature values for ICE PC and stacked bars display the values in SEDOS dataset for different PC, such as ICE, PHEV, BEV and FCEV for (Berry and Fels, 1972; Galitsky and Worrell, 2008; Geckler et al., 2020; Kobayashi, 1997; Sato and Nakata, 2020; Schuckert et al., 1997; Sullivan and Hu, 1995).

by using a structured approach to data management, documentation, and standardization. Each component of the described method and infrastructure contributes to ensuring that the dataset remains well-documented, machine-readable, and reusable across different modeling frameworks.

The SEDOS documentation plays a crucial role in ensuring Findability and Reusability by providing clear guidelines on dataset structure, metadata usage, and integration workflows. By being maintained in a Git repository, the documentation is transparent, version-controlled, and accessible to all users. Additionally, the SEDOS dashboard enhances Accessibility by providing an interactive way to explore both the model structure and the input data. Through its network graph, table view, and aggregation features, users can intuitively navigate the

dataset and extract relevant information without requiring direct database access.

To support Interoperability, extensive use of standardized table and metadata formats has been made in the data compilation. All data is structured in a column-based format, where general information is complemented by parameter-specific columns, ensuring clarity and consistency. Each table is accompanied by metadata, following a metadata standard, which enhances machine readability and facilitates automated processing. Furthermore, all used concepts are annotated making use of the OEO and are thus richly described with accurate and relevant attributes.

Furthermore, by utilizing the OEP and the Open Energy Databus, SEDOS ensures Findability and Accessibility. The integration of these

external infrastructures allows for structured storage, discovery, and retrieval of data, while the metadata is registered and assigned with a persistent and unique identifier for better searchability. This ensures that datasets remain openly available and can be efficiently referenced by researchers and modelers. Finally, the results of this work promote Reusability, as they are published under an open license.

5. Discussion and conclusion

The SEDOS dataset complements the existing open energy modeling datasets by combining a comprehensive sector-coupled, techno-economically detailed representation of the German energy system in the form of a single-node (non-spatial) model with hourly time series and flexible technology aggregation. Users can choose different levels of technological detail within each sector depending on their needs. This makes SEDOS especially valuable for the analysis of long-term transformation pathway assessments using bottom-up energy models that require harmonized data across sectors, without committing to a pre-defined inflexible model setup. In doing so, it offers significant added value compared to other datasets, which are far less detailed in technological terms, are not structured or documented in a comparable manner, or are not available for Germany. By taking into account numerous sectoral interfaces such as electric heating, grid feed-in from battery electric vehicles and numerous processes for the electricity-based production of fuels – often modeled as multi-input-multi-output processes – the SEDOS dataset opens up numerous new analysis options for evaluating the future role of flexible sector coupling in Germany. The dataset ensures coherent coupling between sectors by using a shared global time axis to which all sources are aligned during ingestion. Data from different sectors and methods are synchronized through consistent timestamps, resampling rules, and standardized metadata schemas, ensuring cross sector comparability.

Due to the focus on a very wide variety of technologies across all sectors, spatial disaggregation, e.g. by federal state, has been omitted. Consequently, regional effects of sector coupling, which may differ between urban and rural regions, for example, cannot be analyzed. Aggregating all facilities into a single node limits the analysis of individual energy system components, whether they are industrial production facilities, district heating networks, or power plants. Their transformation must therefore be examined in more detail using complementary approaches. Furthermore, the dataset is not suitable for use in analyses focusing on energy networks. Rather, the focus is on sectoral interactions and how these can be utilized to achieve cost-effective implementation of emission reductions.

The SEDOS dataset was designed to encompass as wide a range of technologies as possible, while still allowing for flexible aggregation. The sheer size of the dataset makes it very challenging to use it in its entirety and without aggregation in a model that optimizes the capacities of all modeled technologies as they evolve along a transformation path. Rather, the dataset is designed to enable single-sector analysis, which has already been demonstrated in various modeling frameworks. The analyses conducted using this approach allow, among other things, broad sensitivity analyses of individual assumptions in the SEDOS dataset.

Even though it comprises more than 2000 technologies, the SEDOS dataset cannot claim to be exhaustive. This applies in particular to technologies at early stages of development, such as floating river hydro power, airborne wind energy, or underwater pumped storage, whose future role in the energy system is highly uncertain. Furthermore, demand from agriculture, forestry and fishing was not considered due to its small scale.

A particular focus in the compilation and publication of the dataset was on the rigorous implementation of the FAIR principles, which creates substantial additional value as compared to other open datasets. By adopting established standards, well-documented structures and openly accessible repositories, our work maximizes the usability of the dataset

for the energy system modeling community. SEDOS differentiates itself conceptually from other FAIR-aligned energy datasets not only through its broader technology coverage, but also through several fundamental design choices. A key distinction lies in the explicit integration of CO₂ accounting within the dataset structure, enabling consistent and transparent tracking of emissions across technologies and sectors, which is not systematically addressed in many existing datasets and modeling frameworks. In addition, SEDOS provides a substantially richer and more standardized metadata layer. While other datasets may aim for FAIR alignment, SEDOS targets a higher level of FAIRness by offering detailed, structured, and machine-readable metadata that enhance discoverability, interoperability, and reuse. This includes the provision of comprehensive metadata already at the stage of initial data publication, rather than requiring users to reconstruct or infer such information retrospectively. Furthermore, interoperability has been a central design principle. SEDOS includes clearly defined interfaces and mappings that facilitate its integration with multiple energy system modeling frameworks, thereby reducing preprocessing requirements and enabling broader applicability. In this context, the dataset is not tailored to a single modeling environment but is designed to be compatible with different frameworks and modeling approaches. Finally, SEDOS improves usability by providing built-in data visualization capabilities, supporting users in exploring and understanding the data.

SEDOS describes the future development of societies and technologies. These developments are inherently subject to significant uncertainties. Political, social, and technological disruptions can lead to unforeseen shifts—for example, in energy demand or techno-economic parameters—that are not reflected in the SEDOS dataset. Rather, the dataset incorporates the future expectations of the primary sources. In compiling the dataset, various data sources were considered wherever possible to derive values that are as robust as possible. Nevertheless, the SEDOS dataset is subject to the uncertainties inherent in future scenario. This is particularly true as it contains projections until the year 2070, which opens the possibility for longer planning period considering economic and demographic development after 2050. This also enables an easier update over time, when improved projections are becoming available. Nevertheless, there is greater uncertainty for the data in the distant future, which is exacerbated by the limited availability of primary data. To address this aspect, we decided to have short time-steps for the closer future and longer for the far future. Besides that, a generally higher uncertainty of data is related to technologies in early stages of technological learning, such as some fuel production technologies or hydrogen airplanes.

The SEDOS dataset as a result of this work is a highly relevant resource for energy system analysis, offering structured and accessible open-source data that supports the assessments of energy infrastructure, policies, and development efforts. By centralizing data on the German energy system, it has the potential to reduce the time and effort required by researchers and organizations to collect, organize, and analyze model input data. This efficiency enables a more effective focus on the modeling work, ultimately aiding decision-making.

CRedit authorship contribution statement

Hedda Gardian: Writing – review & editing, Writing – original draft, Visualization, Validation, Formal analysis, Investigation, Data curation, Conceptualization. **Hans Christian Gils:** Writing – review & editing, Writing – original draft, Supervision, Project administration, Funding acquisition, Conceptualization. **Beneharo Reveron Baecker:** Writing – review & editing. **Samuel Hasselwander:** Writing – original draft, Visualization, Validation, Formal analysis, Investigation, Data curation. **Hendrik Huyskens:** Writing – review & editing, Software. **Anik Islam:** Writing – original draft, Visualization, Validation, Formal analysis, Investigation, Data curation. **Gian Müller:** Writing – original draft, Visualization, Validation, Formal analysis, Investigation, Data curation. **Viktor Slednev:** Writing – original draft, Visualization, Validation,

Formal analysis, Investigation, Data curation. **Jonas Winkler:** Writing – original draft, Visualization, Validation, Formal analysis, Investigation, Data curation. **Ulrich Fahl:** Writing – review & editing. Writing – original draft, Methodology, Data curation, Supervision, Project administration, Funding acquisition.

Funding sources

This work is part of the SEDOS project funded by the German Federal Ministry of Economic Affairs and Energy (BMWE) under the grant numbers 03EI1040A-F.

Declaration of Competing Interest

The authors declare that they have no known competing financial interests or personal relationships that could have appeared to influence the work reported in this paper.

Acknowledgements

The authors gratefully acknowledge the contributions of Eugenio Salvador Arellano Ruiz, Isela Bailey, Johannes Behrens, Sarah Berendes, Markus Blesl, Ilka Cufmann, Sabine Haas, Kerstin Haller, Carsten Hoyer-Klick, Patrick Jochem, Fabia Miorelli, Christoph Muschner, Felicitas Ortlieb, Dimitris Tsoutsouloupoulos, Jann Weinand, and Niklas Wulff to the data acquisition, modeling and supervision.

Data Availability

All data compiled within this work is openly accessible through the Open Energy Platform (OEP), where they can be found under the tag “SEDOS.” Detailed documentation of the dataset structure is provided in the associated Zenodo repository (Reveron Baecker et al., 2025) and described in (Reveron Baecker et al., 2024).

References

- ADAC2024. ADAC Fahrzeugdatenbank: Technische Fahrzeugdaten – aktuelle Modelle. version Juli 2024. Allgemeiner Deutscher Automobil-Club e.V. Available online: (https://www.adac.de/rund-ums-fahrzeug/autokatalog/marken-modelle/?sort=SORTI NG_DESC) (accessed 5 November 2025).
- Ancona, M.A., Antonucci, V., Branchini, L., et al., 2022. Parametric Thermo-Economic Analysis of a Power-to-Gas Energy System with Renewable Input, High Temperature Co-Electrolysis and Methanation (Available online). *Energies* 15 (5), 1791. <https://doi.org/10.3390/en15051791>.
- Argonne National Laboratory2022. GREET2 MODEL(Version: GREET2_2022). Available online: (<https://greet.anl.gov/greet.models>) (accessed 5 November 2025).
- Ariadne2021. Ariadne Scenario Explorer (project-internal) – Phase 1 (2020–2023). Related to the Ariadne project, see (<https://ariadneprojekt.de/>) (accessed 5 November 2025).
- Bazzanella M.A., Ausfelder, F. 2017. Low carbon energy and feedstock for the European chemical industry. Available online: (https://dechema.de/dechema_media/Downloads/Positionspapiere/Technology_study_Low_carbon_energy_and_feedstock_for_the_European_chemical_industry.pdf) (accessed 5 November 2025).
- Berry, R.S., Fels, M.F. 1972. The Production and Consumption of Automobiles, A Report to the Illinois Institute For Environmental Quality.
- BMWE2019. Automobile Value Creation 2030-2050. Federal Ministry for Economic Affairs and Energy. Available online: (<https://www.bundeswirtschaftsministerium.de/Redaktion/DE/Publikationen/Studien/automobile-wertschoepfung-2030-2050.pdf?blob=publicationFile&v=1>) (accessed 5 November 2025).
- Booshehri, M., Emele, L., Flügel, S., et al., 2021. Introducing the Open Energy Ontology: Enhancing data interpretation and interfacing in energy systems analysis (Available online). *Energy AI* 5 (2021), 100074. <https://doi.org/10.1016/j.egyai.2021.100074>.
- Brinkerink, M., Sherman, G., Osei-Owusu, S., et al., 2024. A global electricity transmission database for energy system modelling (Available online). *Data Brief* 54 (2024), 110420. <https://doi.org/10.1016/j.dib.2024.110420>.
- Brodecki, L. 2024. Modeling and Assessment of Energy Self-Sufficiency in Urban Energy Systems. PhD thesis.
- Brynof, S., Taljegard, M., Grahn, M., Hansson, J., 2017. Electrofuels for the transport sector: A review of production costs (Available online). *Renew. Sustain. Energy Rev.* 81 (2017), 1887–1905. <https://doi.org/10.1016/j.rser.2017.05.288>.
- Buttler, A., Spliethoff, H., 2017. Current status of water electrolysis for energy storage, grid balancing and sector coupling via power-to-gas and power-to-liquids: A review (Available online). *Renew. Sustain. Energy Rev.* 82 (2017), 2440–2454. <https://doi.org/10.1016/j.rser.2017.09.003>.
- Cufmann, I., Schachler, B., Büttner, C., et al., 2024. eGon - Ein offenes netzebenen- und sektorenbereichendes Planungsinstrument zur Bestimmung des optimalen Einsatzes und Ausbaus von Flexibilitätsoptionen in Deutschland. Available online: (<https://zenodo.org/records/10677901>) (accessed 5 November 2025).
- Danish Energy Agency2025a. Technology Data – Energy Plants for Electricity and District Heating Generation, Available online: (<https://ens.dk/en/analyses-and-statistics/technology-data-generation-electricity-and-district-heating>) (accessed 5 November 2025).
- Danish Energy Agency2025b. Technology data for renewable fuels. Available online: (<https://ens.dk/en/analyses-and-statistics/technology-data-renewable-fuels>) (accessed 5 November 2025).
- DBpedia Association2023. Open Energy Databus. Available online: (<https://databus.openenergyplatform.org/>). (accessed 5 November 2025).
- dena2019. Roadmap Power to Gas. Available online: (https://web.archive.org/web/20221219223211/https://www.dena.de/fileadmin/dena/Publikationen/PDFs/2019/Roadmap_Power_to_Gas.pdf) (accessed 5 November 2025).
- Deng, Y., Cao, K.-K., Hu, W., et al., 2023. Harmonized and Open Energy Dataset for Modeling a Highly Renewable Brazilian Power System (Available online). *Sci. Data* 10 (103), 1–12. <https://doi.org/10.1038/s41597-023-01992-9>.
- Detz, R.J.J., Reek, N.H., Van Der Zwaan, B.C.C., 2018. The future of solar fuels: when could they become competitive? (Available online). *Energy & Environ. Sci.* 11 (7), 1653–1669. <https://doi.org/10.1039/c8ee00111a>.
- ENTSO-E2024. TYNDP 2024: Europe's electricity infrastructure plan. European Network of Transmission System Operators for Electricity. Available online: (<https://www.entsoe.eu/outlooks/tyndp/2024/tyndp.entsoe.eu+4>) (accessed 5 November 2025).
- ENTSO-E & ENTOSOG2022. TYNDP 2022 Scenarios Report, Available online: (https://2022.entsoe-tyndp-scenarios.eu/wp-content/uploads/2022/04/TYNDP2022_Joint_Scenario_Full_Report-April-2022.pdf) (accessed 5 November 2025).
- ENTSO-E & ENTOSOG2024. Pan European Market Modelling Database (PEMMDB) 2.5, TYNDP 2024 Scenario Input Data. Available online: (<https://2024-data.entsoe-tyndp-scenarios.eu/files/scenarios-inputs/PEMMDB2.zip>) (accessed 5 November 2025).
- European Commission2025. NACE Rev. 2.1: Statistical classification of economic activities in the European Union: 2025 edition. Statistical Office of the European Union. Available online: (<https://data.europa.eu/doi/10.2785/155339>) (accessed 5 November 2025).
- eXtremOS2023. eXtremereignis-bewältigende resiliente Energiesysteme der Zukunft. Available online: (<https://opendata.ffe.de/project/extremos/>) (accessed 5 November 2025).
- Fasihi, M., Bogdanov, D., Breyer, C., 2016. Techno-Economic assessment of Power-to-Liquids (PTL) fuels production and global trading based on hybrid PV-Wind power plants (Available online). *Energy Procedia* 99, 243–268. <https://doi.org/10.1016/j.egypro.2016.10.115>.
- Feldpausch-Jaegers, S., Lefort, N., Lange, M., et al., 2016. Potenzialanalyse LNG-Einsatz von LNG in der Mobilität. Schwerpunkt. und Handl. F. ür. die Tech. Umsetzung. Available Online. (<https://www.dvgw.de/medien/dvgw/forschung/berichte/g201508ms.pdf>).
- Fridgen, G., Keller, R., Körner, M.-F., Schöpf, M., 2020. A holistic view on sector coupling (Available online). *Energy Policy* 147, 111913. <https://doi.org/10.1016/j.enpol.2020.111913>.
- FVV2021. Zukünftige Kraftstoffe: FVV-Kraftstoffstudie IV. Future Fuels: FVV Fuels Study IV. Frankfurt am Main. Available online: (https://www.fvv-net.de/fileadmin/Stories/02050_Sechs_Thesen_zur_Klimaneutralitaet_des_europaeischen_Verkehrssektors/FVV_Future_Fuels_StudyIV_The_Transformation_of_Mobility_H1269_2021-10_EN.pdf) (accessed 5 November 2025).
- Galitsky, C., Worrell, E. 2008. Energy Efficiency Improvement and Cost Saving Opportunities for the Vehicle Assembly Industry, LBNL-50939-Revision.
- Geckler, D., Fliege, H., Nagel, J., Bracht, U., Seewaldt, M., Wolff, D., 2020. Der Energiebedarf der Automobilproduktion im Fokus der Simulation. In: Mayer, G., Pöge, C., Spieckermann, S., Wenzel, S. (Eds.), *Ablaufsimulation in der Automobilindustrie*. Springer Vieweg, Berlin, Heidelberg. https://doi.org/10.1007/978-3-662-59388-2_21.
- Geres, R., Kohn, A., Lenz, S., Ausfelder, F., Bazzanella, A.M., Möller, A. 2019. Roadmap Chemie 2050: auf dem Weg zu einer treibhausgasneutralen chemischen Industrie in Deutschland: eine Studie von DECHEMA and FutureCamp für den VCI. Available online: (<https://www.vci.de/services/publikationen/broschueren-faltblaetter/vci-dechema-futurecamp-studie-roadmap-2050-treibhausgasneutralitaet-chemie-industrie-deutschland-langfassung.jsp>) (accessed 5 November 2025).
- Glenk, G., Reichelstein, S., 2019. Economics of converting renewable power to hydrogen (Available online). *Nat. Energy* 4 (3), 216–222. <https://doi.org/10.1038/s41560-019-0326-1>.
- Global Energy Monitor2025. Available online: (<https://globaleenergymonitor.org>) (accessed 5 November 2025).
- Hilpert, S., Kaldemeyer, C., Krien, U., et al., 2018. The Open Energy Modelling Framework (oemof) - A new approach to facilitate open science in energy system modelling (Available online). *Energy Strategy Rev.* 22, 16–25. <https://doi.org/10.1016/j.esr.2018.07.001>.
- Hirth, L., Mühlenpfordt, J., Schlecht, I., et al., 2019. Open Power System Data: A free and open data platform for power system modelling. Neon Energie, EU Berlin, ETH Zürich, DIW Berlin. Available online: (<https://open-power-system-data.org>) (accessed 5 November 2025).
- Hörsch, J., Hofmann, F., Schlachtberger, D., Brown, T. 2018. PyPSA-Eur: An open sector-coupled optimisation model of the European energy system. Available online: (<https://github.com/pypsa/pypsa-eur>) (accessed 5 November 2025).

- Hoyer-Klick, C., Blesl, M., von Bremen, L., et al., 2023. FAIR Data in Energy Systems Analysis. International Conference on Energy Meteorology, June 27th–29th, 2023, Padova. Available online: (<https://elib.dlr.de/195787/>) (accessed 5 November 2025).
- Hülk, L., Huber, J., Hoffmann, C. and Muschner, C. 2025. Open Energy Family - Open Energy Metadata (OEMetadata), 2.0.3, (<https://github.com/OpenEnergyPlatform/oemetadata/>).
- IEA2019. The Future of Hydrogen - Seizing today's opportunities. Available online: (https://iea.blob.core.windows.net/assets/9e3a3493-b9a6-4b7d-b499-7ca48e357561/The_Future_of_Hydrogen.pdf) (accessed 5 November 2025).
- IEA2025. Energy Statistics Data Browser, International Energy Agency, Available online: (<https://www.iea.org/data-and-statistics/data-tools/energy-statistics-data-browser>) (accessed 5 November 2025).
- IRENA and Methanol Institute2021. Innovation Outlook: Renewable methanol. Available online: (<https://www.irena.org/publications/2021/Jan/Innovation-Outlook-Renewable-Methanol>) (accessed 5 November 2025).
- IWU2012. TABULA, 2012. Institut Wohnen und Umwelt GmbH. Available online: (<https://www.iwu.de/index.php?id=205>) (accessed 5 November 2025).
- IWU2021. Forschungsdatenbank Nichtwohngebäude 2019. Institut Wohnen und Umwelt GmbH. Available online: (<https://www.datanwg.de/forschungsdatenbank/>) (accessed 5 November 2025).
- Jensen, T., Pinson, P., 2017. RE-Europe, a large-scale dataset for modeling a highly renewable European electricity system (Available online:). *Sci. Data* 4, 170175. <https://doi.org/10.1038/sdata.2017.175>.
- Jungmeier, G., Canella, L., Pucker-Singer, J., Beermann, M. 2019. Geschätzte Treibhausgasemissionen und Primärenergieverbrauch in der Lebenszyklusanalyse von Pkw-basierten Verkehrssystemen.
- KBA2012. Kraftfahrzeugverkehr in Deutschland - KiD 2010. Kraftfahrtbundesamt. Available online: (www.forschungsinformationssystem.de/servlet/is/587267/) (accessed 5 November 2025).
- KBA, 2021. Bestand an Kraftfahrzeugen und Kraftfahrzeuganhängern nach Herstellern und Typen (FZ 6. Kraftfahrt-Bundesamt).
- KEA2024. Technical Catalog for Municipal Heat Planning. Edited by KEA-BW. Available online: (https://www.kea-bw.de/fileadmin/user_upload/Waermewende/Wissensportal/Technikkatalog_Tabellen_v1.1.zip) (accessed 5 November 2025).
- Klütz, T., Knosala, K., Behrens, J., et al., 2025. ETHOS.FINE: A Framework for Integrated Energy System Assessment (Available online:). *J. Open Source Softw.* 10 (105), 6274. <https://doi.org/10.21105/joss.06274>.
- Kobayashi, O., 1997. Car Life cycle Inventory assessment (Available online:). *SAE Tech. Pap.* <https://doi.org/10.4271/971199> (accessed 5 November 2025).
- Lerede, D.L., Di Cosmo, V., Savoldi, L., 2024. TEMOA-Europe: An open-source and open-data energy system optimization model for the analysis of the European energy mix (Available online:). *Energy* 308, 132850. <https://doi.org/10.1016/j.energy.2024.132850>.
- Lindner, M., Seibold, T., Geis, J., et al., 2025. PyPSA-DE - Hochaufgelöstes, sektorengerechtes Modell des deutschen Energiesystems. Available online: (<https://zenodo.org/records/15350847>) (accessed 5 November 2025).
- Loulou, R., Goldstein, G., Kanudia, A., et al., 2016. Documentation for the TIMES Model, International Energy Agency. Available online: (https://github.com/etsap-TIME_S/TIMES_Documentation/tree/master) (accessed 5 November 2025).
- Marettke, S., Hoymann, J., Schlömer, C., 2024. *Spatial Planning Forecast 2045: Population Forecast*. Edited by Federal Institute for Research on Building, Urban Affairs and Spatial. Development (BBSR). (<https://tableau.bsh.de/t/bbr/views/Raumordnungsprognose2045/Titel>).
- Mendelevitch, R., Repenning, J., Matthes, F.C. et al., 2024. Treibhausgas-Projektionen 2024 für Deutschland – Rahmendaten. ISSN 1862-4359. Available online: (https://www.umweltbundesamt.de/sites/default/files/medien/11850/publikationen/projektionsbericht_2024_rahmendatenpapier.pdf) (accessed 5 November 2025).
- MID2017. Mobilität in Deutschland - MID Ergebnisbericht. infas, DLR, IVT and infas 360. Available online: (<https://mobilitaet-in-deutschland.de>) (accessed 5 November 2025).
- Miorelli, F., Wulff, N., Fuchs, B., Gils, H.C., Jochem, P., 2024. venco.py: A Python model to represent the charging flexibility and vehicle-to-grid potential of electric vehicles in energy system models (Available online:). *J. Open Source Softw.* 10 (108), 6896. <https://doi.org/10.21105/joss.06896>.
- Müller, G., Kullmann, F., Linssen, J., Stolten, D., 2025. The costs of future energy technologies: A comprehensive review of power-to-X processes (Available online:). *J. CO2 Util.* 92, 103019. <https://doi.org/10.1016/j.jcou.2025.103019>.
- Müller, U.P., Schachler, B., Bunke, W.-D., et al., 2019. open.eGo - Netzebenenübergreifendes Planungsinstrument - zur Bestimmung des optimalen Netz- und Speicherausbaus in Deutschland - integriert in einer OpenEnergyPlatform. Project report. ISSN: 2196-7164. Available online: (<https://www.uni-flensburg.de/fileadmin/content/abteilungen/industrial/dokumente/downloads/veroeffentlichungen/forschungsergebnisse/20190426endbericht-opene-go-kz0325881-final.pdf>) (accessed 5 November 2025).
- Nijs, W., Ruiz, P. 2019. 01_JRC-EU-TIMES Full model. European Commission, Joint Research Centre (JRC) Available online: (<https://data.jrc.ec.europa.eu/dataset/8141a398-41a8-42fa-81a4-5b825a51761b#description>) (accessed 5 November 2025).
- NREL2025. NREL Data Catalog. National Renewable Energy Laboratory. Available online: (<https://data.nrel.gov>) (accessed 5 November 2025).
- OEP 2025. Open Energy Family - Open Energy Platform (OEP), 1.1.0, Available online: (<https://openenergyplatform.org/>) (accessed 5 November 2025).
- Parigi, D., Giglio, E., Soto, A., Santarelli, M., 2019. Power-to-fuels through carbon dioxide Re-Utilization and high-temperature electrolysis: A technical and economic comparison between synthetic methanol and methane (Available online:). *J. Clean. Prod.* 226, 679–691. <https://doi.org/10.1016/j.jclepro.2019.04.087>.
- Qi, M., Park, J., Landon, R.S., et al., 2021. Continuous and flexible Renewable-Power-to-Methane via liquid CO2 energy storage: Revisiting the techno-economic potential (Available online). *Renew. Sustain. Energy Rev.* 153, 111732. <https://doi.org/10.1016/j.rser.2021.111732>.
- Reksten, A.H., Thomassen, M.S., Møller-Holst, S., Sundseth, K., 2022. Projecting the future cost of PEM and alkaline water electrolyzers, a CAPEX model including electrolyser plant size and technology development (Available online:). *Int. J. Hydrog. Energy* 47 (90), 38106–38113. <https://doi.org/10.1016/j.ijhydene.2022.08.306>.
- Reveron Baecker, B., Hamacher, T., Slednev, V., et al., 2024. Comprehensive and open model structure for the design of future energy systems with sector coupling (Available online:). *Renew. Sustain. Energy Transit.* 6, 100094. <https://doi.org/10.1016/j.rset.2024.100094>.
- Reveron Baecker, B., Gardian, H., Islam, A., et al., 2025. SEDOS Model Structure. Available online: (<https://doi.org/10.5281/zenodo.17105060>) (accessed 5 November 2025).
- Salomone, F., Giglio, E., Ferrero, D., et al., 2018. Techno-economic modelling of a Power-to-Gas system based on SOEC electrolysis and CO2 methanation in a RES-based electric grid (Available online:). *Chem. Eng. J.* 337 (2018), 120233. <https://doi.org/10.1016/j.cej.2018.10.170>.
- Sato F.E.K., Nakata, T. 2020. Energy Consumption Analysis for Vehicle Production through a Material Flow Approach. Available online: (<https://doi.org/10.3390/en13092396>) (accessed 5 November 2025).
- Schnuelle, C., Thoeming, J., Wassermann, T., Thier, P., Von Gleich, A., Goessling-Reisemann, S., 2019. Socio-technical-economic assessment of power-to-X: Potentials and limitations for an integration into the German energy system (Available online:). *Energy Res. & Soc. Sci.* 51, 187–197. <https://doi.org/10.1016/j.erss.2019.01.017>.
- Schuckert, M., Beddies, H., Gediga, J., Florin, H., Eyerer, P., Schweimer, G.W., 1997. Life cycle inventories - new experiences to save environmental loads and costs (Available online:). *SAE Tech. Pap.* <https://doi.org/10.4271/971171>.
- SEDOS2024a. SEDOS dashboard. Available online: (<https://sedos.apps.rl-institut.de/>) (accessed 5 November 2025).
- SEDOS2024b. SEDOS Documentation. Available online: (<https://sedos-project.github.io/github/>) (accessed 5 November 2025).
- SEDOS2024c. SEDOS project git repository. Available online: (<https://github.com/sedos-project>) (accessed 5 November 2025).
- SEDOS2024d. SEDOS GUI. Available online: (<https://sedos.apps.rl-institut.de/>) (accessed 5 November 2025).
- SEDOS project team2025. SEDOS - The impact of sector integration in the context of the energy transition in Germany - modeling with a national open source reference energy system. Available online: (<https://www.dlr.de/ve/forschung-und-transfer/projekte/2022/projekt-sedos>) (accessed 5 November 2025).
- Slednev, V., 2024. Development of a techno-economic energy system model considering the highly resolved conversion and multimodal transmission of energy carriers on a global scale." PhD thesis. Karlsruhe Institut für Technologie (KIT), 2024. Available online: (<https://doi.org/10.5445/IR/1000170863>) (accessed 5 November 2025).
- Slednev, V., Bertsch, V., Ruppert, M., Fichtner, W., 2018. Highly resolved optimal renewable allocation planning in power systems under consideration of dynamic grid topology (Available online:). *Comput. & Oper. Res.* 96, 281–293. <https://doi.org/10.1016/j.cor.2017.12.008>.
- Smolinka, T., Wiebe, N., Sterchele, P. et al., 2018. Studie IndWEDE Industrialisierung der Wasserelektrolyse in Deutschland: Chancen und Herausforderungen für nachhaltigen Wasserstoff für Verkehr, Strom und Wärme. Available online: (https://www.now-gmbh.de/wp-content/uploads/2020/09/indwede-studie_v04.1.pdf) (accessed 5 November 2025).
- Soler, A. 2020. Role of e-fuels in the European transport system - Literature review. Available online: (https://www.concawe.eu/wp-content/uploads/Rpt_19-14.pdf) (accessed 5 November 2025).
- Soler, A., Gordillo, V., Lilley, W., et al., 2022. e-fuels: A technoeconomic assessment of European domestic production and. Imports Towards 2050. (https://www.concawe.eu/wp-content/uploads/Rpt_22-17.pdf) (accessed 5 November 2025).
- Staffell, I., Pfenninger, S., 2016. Using bias-corrected reanalysis data to simulate current and future wind power output (Available online:). *Energy* 114, 1224–1239. <https://doi.org/10.1016/j.energy.2016.08.068>.
- Sullivan, J.L., Hu, J., 1995. Life cycle energy analysis for automobiles. *SAE Tech. Pap.* <https://doi.org/10.4271/951829> (accessed 5 November 2025).
- Thema, M., Bauer, F., Sterner, M., 2019. Power-to-Gas: Electrolysis and methanation status review (Available online:). *Renew. Sustain. Energy Rev.* 112, 775–787. <https://doi.org/10.1016/j.rser.2019.06.030>.
- TransHyDE2024. Transporttechnologien für Wasserstoff. Available online: (<https://www.wasserstoff-leitprojekte.de/projekte/transhyde>) (accessed 5 November 2025).
- Agora Verkehrswende, Agora Energiewende and Frontier Economics 2018. The Future Cost of Electricity-Based Synthetic Fuels. Available online: (https://www.agora-energie-wende.de/fileadmin/Projekte/2017/SynKost_2050/Agora_SynKost_Study_EN_WEB.pdf) (accessed 5 November 2025).
- Wang, L., Chen, M., Küngas, R., et al., 2019. Power-to-fuels via solid-oxide electrolyzer: Operating window and techno-economics (Available online:). *Renew. Sustain. Energy Rev.* 110, 174–187. <https://doi.org/10.1016/j.rser.2019.04.071>.

Wilkinson, M., Dumontier, M., Aalbersberg, I., et al., 2016. The FAIR Guiding Principles for scientific data management and stewardship (Available online). *Sci. Data* 3, 160018. <https://doi.org/10.1038/sdata.2016.18>.

Zauner, A., Böhm, H., Rosenfeld, D.C., Tichler, R., 2019. Innovative large-scale energy storage technologies and Power-to-Gas concepts after optimization. Available online:

<https://ec.europa.eu/research/participants/documents/downloadPublic?documentIds=080166e5c58ae3ff&appId=PPGMS> (accessed 5 November 2025).

Zhou, Y., Searle, S., Pavlenko, N., 2022. Current and future cost of e-kerosene in the United States and Europe. Available online: (<https://theicct.org/wp-content/uploads/2022/02/fuels-us-europe-current-future-cost-ekerosene-us-europe-mar22.pdf>) (accessed 5 November 2025).