

# LASER PROPULSION

Lectures on Unconventional Space Propulsion

IRS Institute of Space Systems, University of Stuttgart

January 21, 2026

Dr. Raoul-Amadeus Lorbeer, DLR Institute of Technical Physics

(Slides by Dr. Stefan Scharring)



The background of the slide is a high-resolution photograph of a satellite in orbit above Earth. The satellite is a rectangular platform with two long, parallel solar panel arrays extending outwards. The panels are covered in a grid of small solar cells. The satellite's central body is complex, with various instruments and antennas visible. Below the satellite, the Earth's surface is visible, showing a mix of green landmasses and blue oceans, partially obscured by white clouds. The curvature of the Earth is visible on the right side of the image.

# I. INTRODUCTION

# Institute of Technical Physics

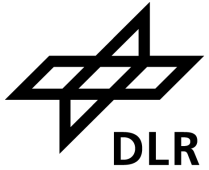

Head of Institute: Prof. Dr. Thomas Dekorsy

Laser systems for:

## Aeronautics

Flight instruments

## Space

Detection and characterization of space debris

## Security

Standoff detection

## Defense

Long-range laser effectors

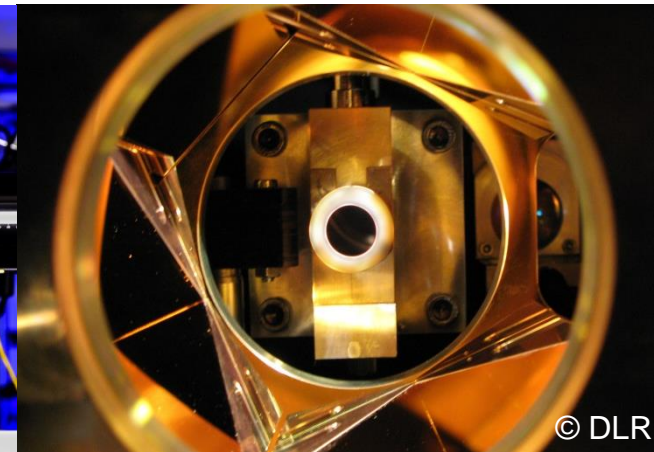
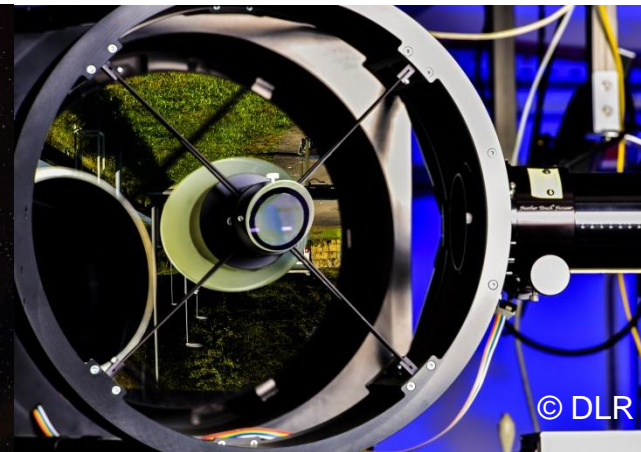



**(UN)CONVENTIONAL SPACE  
PROPULSION**

# Every in space thruster (ever)

$$F_{S/C} = \dot{p}_{S/C} = -\dot{p}_t = -F_t$$

- Newton: “To every action (force) there is always opposed an equal reaction”
- Change in impulse of the „exhaust“ media, while passing through the “thruster”:

$$\dot{p}_t = \dot{p}_t^{after} - \dot{p}_t^{before}$$

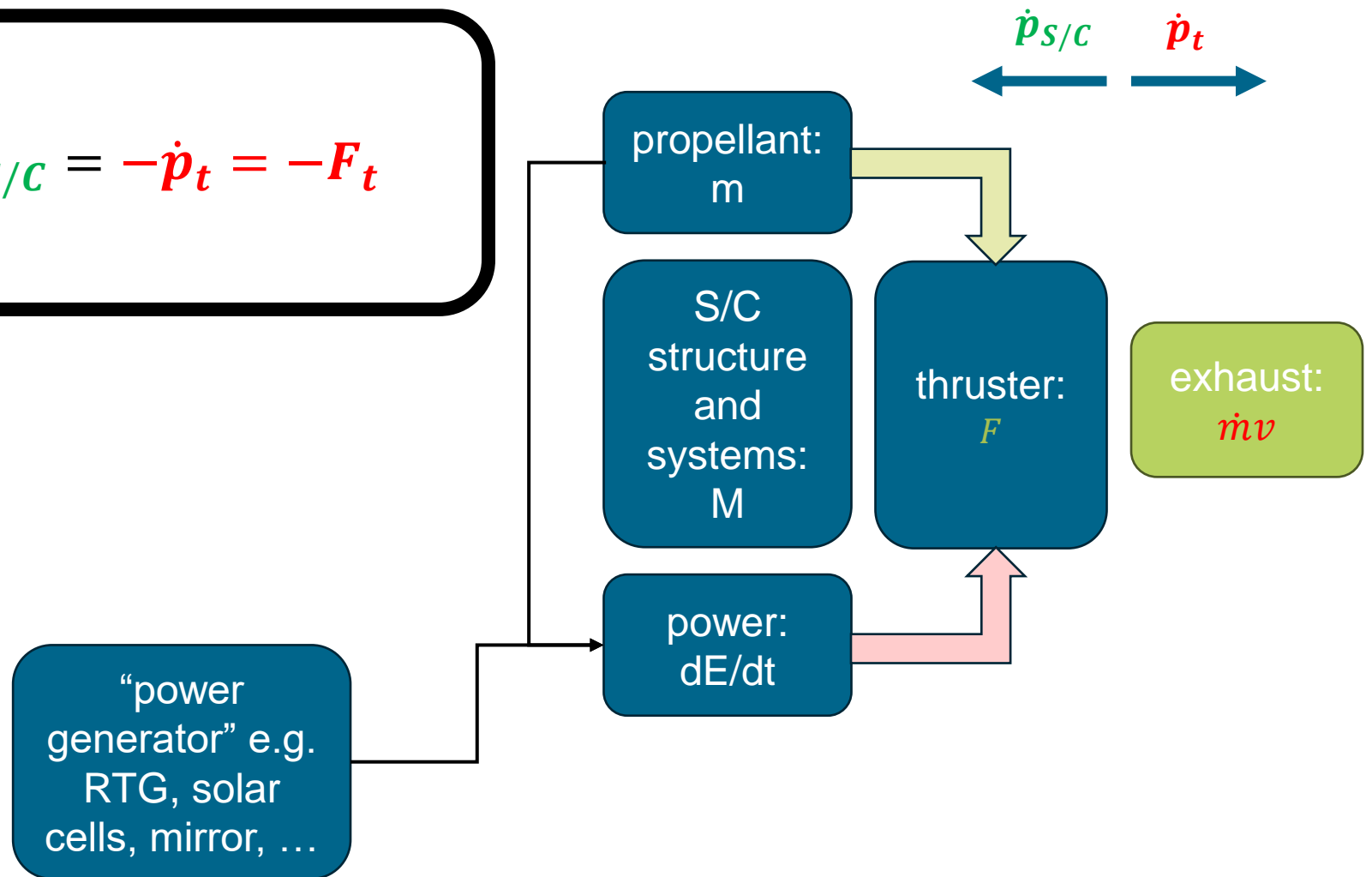

# Every in space thruster (ever)



$$E = \frac{1}{2}mv^2$$

$$P = \frac{dE}{dt} = \frac{1}{2}(\dot{m}v^2 + 2vm\dot{v})$$

$$P = \dot{m}v^2/2 + vF$$

- Energy
- Mass
- => Force
- => Impulse
- Exhaust velocity:  $v$ 
  - $ISP = \frac{v}{g} = \frac{v}{9.81 \text{ m/s}^2}$

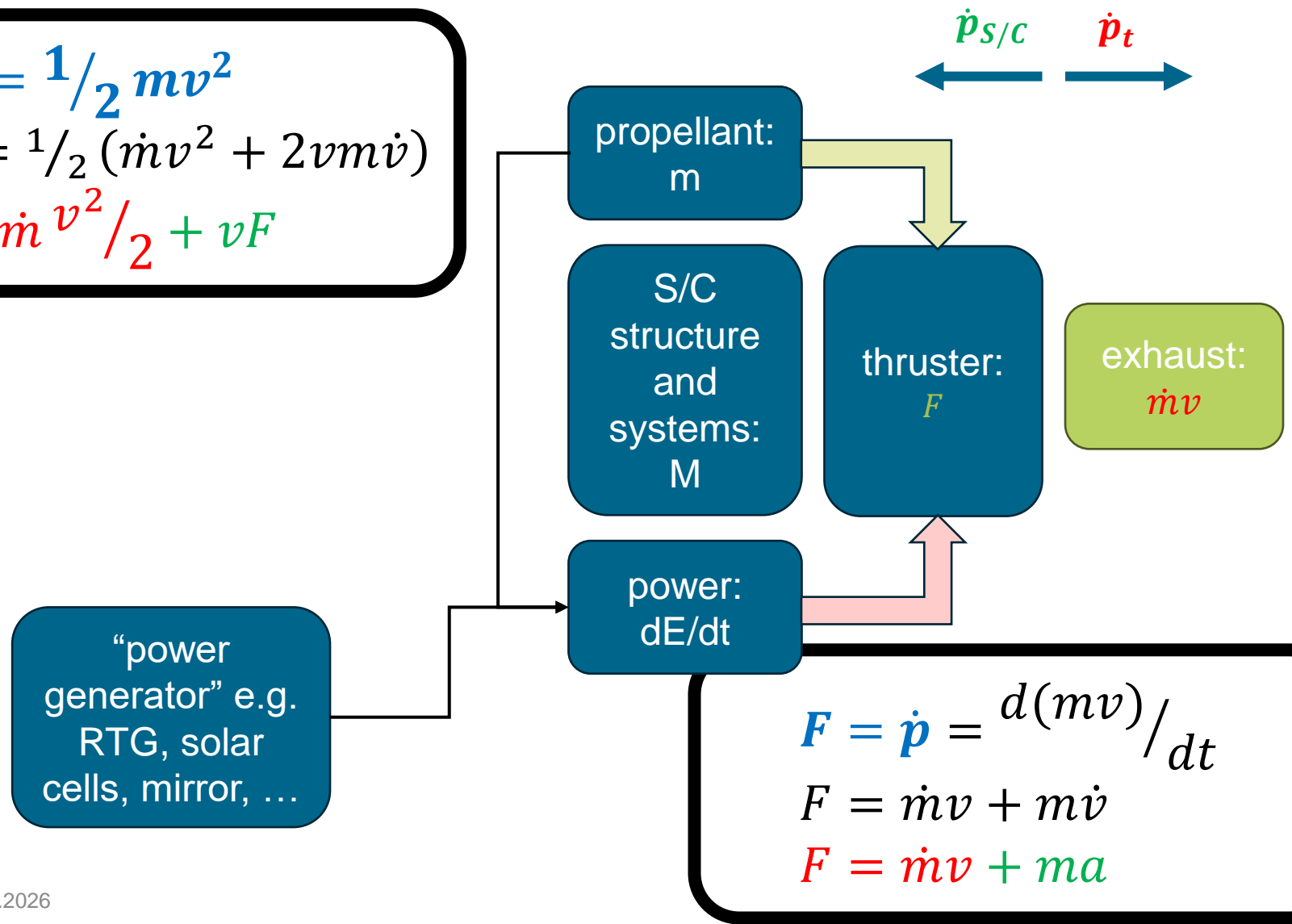

$$F = \dot{p} = \frac{d(mv)}{dt}$$

$$F = \dot{m}v + m\dot{v}$$

$$F = \dot{m}v + ma$$

# THE Figure of Merit in Laser Propulsion

- Impulse (Momentum) coupling coefficient  $c_m$

$$c_m = \frac{F}{P_L} = \frac{\Delta p}{E_L}$$

$F$ : thrust

$P_L$ : average laser power

$\Delta p$ : imparted momentum

$E_L$ : laser pulse energy

- System** momentum coupling coefficient

$c_{m,sys}$

$$c_{m,sys} = \frac{F}{P_{el}} = \eta_{eo} \frac{F}{P_L}$$

= Thrust/power ratio in electric propulsion

- Efficiency of electro-optical energy conversion  $\eta_{eo}$

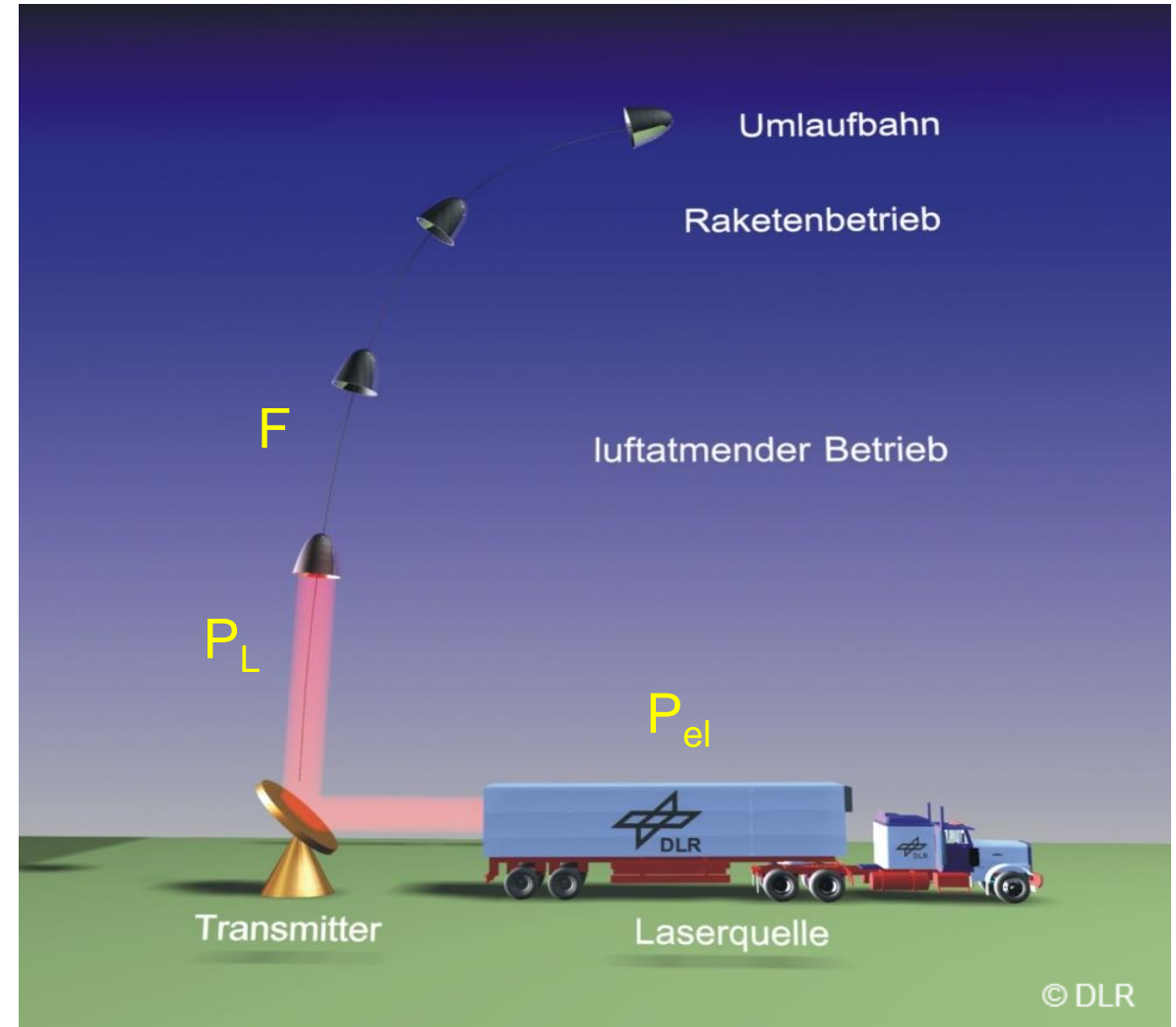

# Laser propulsion is electric propulsion

## From EM to Laser-Propulsion

- Electric Propulsion (EP) uses a separate power source:
  - Radioisotope Thermoelectric Generator (RTG)
  - Solar panel
- To create electromagnetic (EM) fields.
- And accelerate propellant via thermal expansion and/or EM-fields.
- **Most EP involves electrodes.**

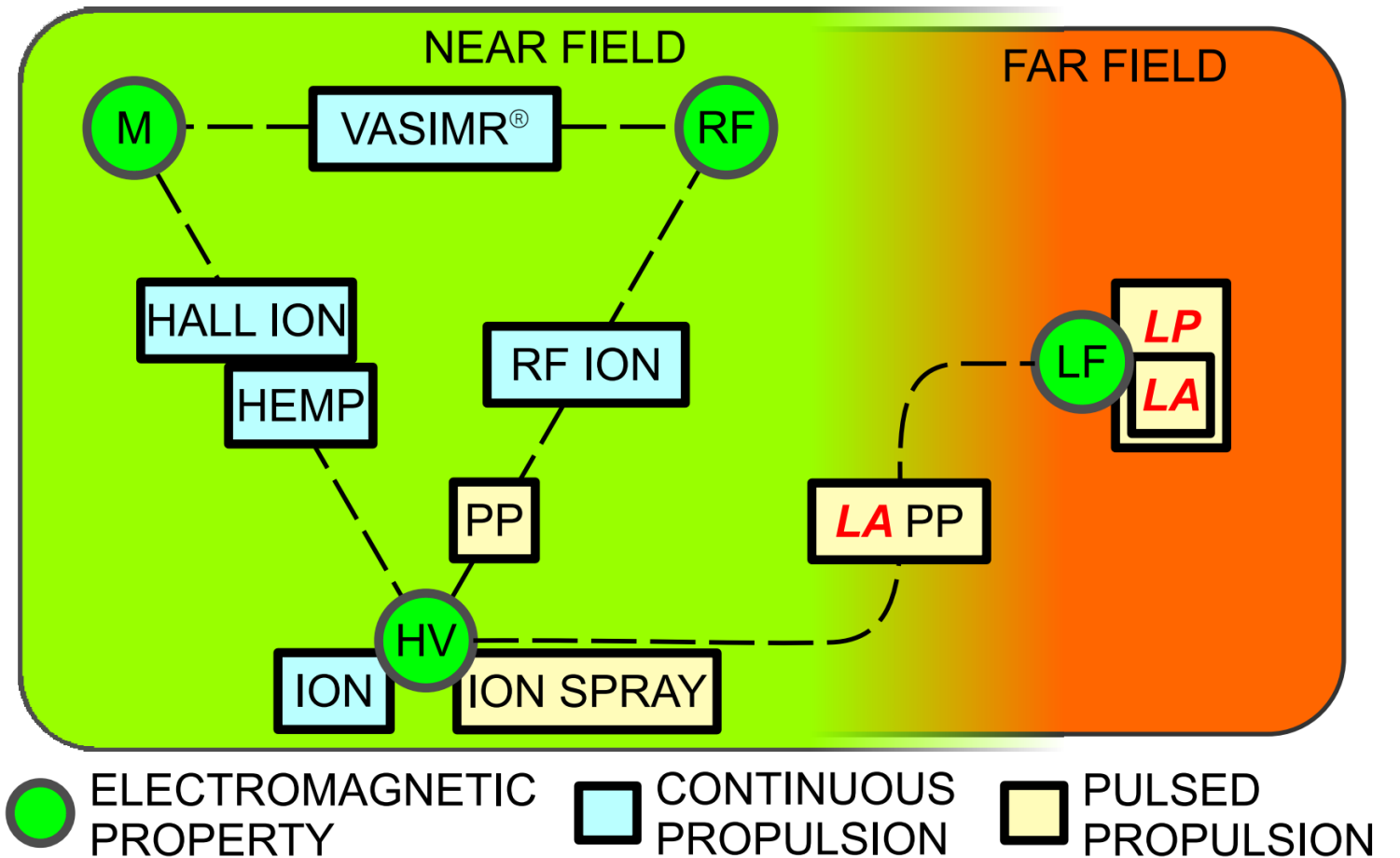

Scharring, S., Karg, S., Lorbeer, R. A., Dahms, N., & Eckel, H. A. (2015). Low-noise thrust generation by laser-ablative micropropulsion. In *Konferenz-DVD*.

A satellite with large solar panels is shown in orbit above Earth. The satellite is oriented horizontally, with its solar panels extending outwards. The Earth's surface below shows a mix of green land and blue water, with a thin white cloud layer. The curvature of the Earth is visible on the right side of the image.

# LASER APPLICATIONS

# Laser Applications: Science, Vision and Fiction

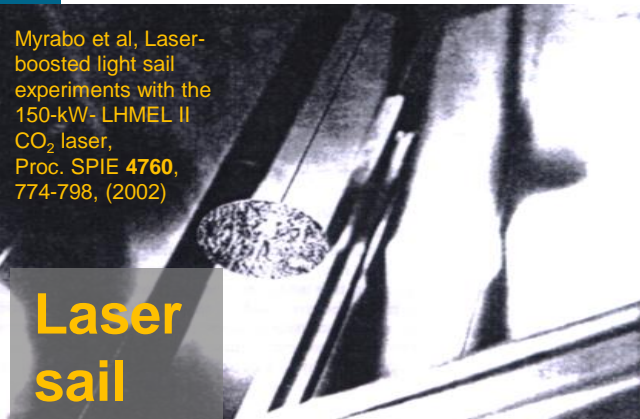

Myrabo et al, Laser-boosted light sail experiments with the 150-kW- LHMEI II CO<sub>2</sub> laser, Proc. SPIE 4760, 774-798, (2002)

**Laser sail**



**Laser power beaming**

Image credits: Ascending Technologies



**Laser cutting**

Image credits: Quander Metall- und Lasertechnik



**Eye surgery**

Image credits: Dr. med. Inken Lamcke, Femto- Lasik – PRK



**Photon rocket**

Image credits: Bundeshandelsschule Völkermarkt

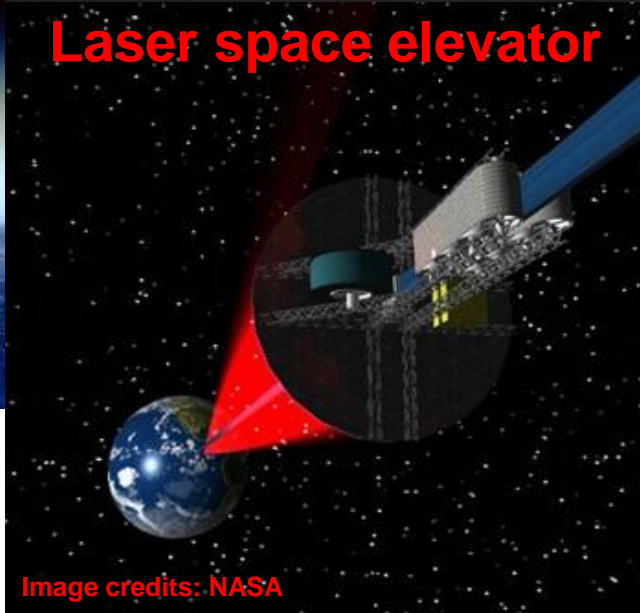

**Laser space elevator**

Image credits: NASA



**Light saber**

Image credits: Sandra M. H. Pixabay



Image credits: Anua22a

**Death ray**

# Definitions and Examples

## Laser Thruster

Thruster in which laser energy contributes substantially and indispensably to kinetic energy.

## Lightcraft (in the broader sense)

Thruster based on electromagnetic radiation (laser or microwave)

## Lightcraft (in the narrower sense)

Thruster based on detonations induced by a remote laser source

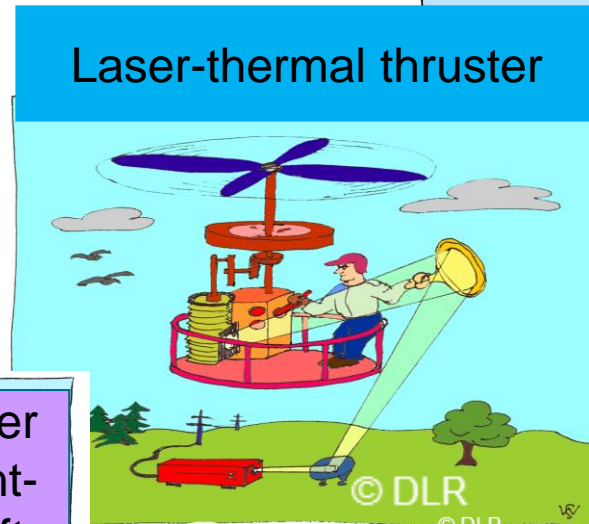
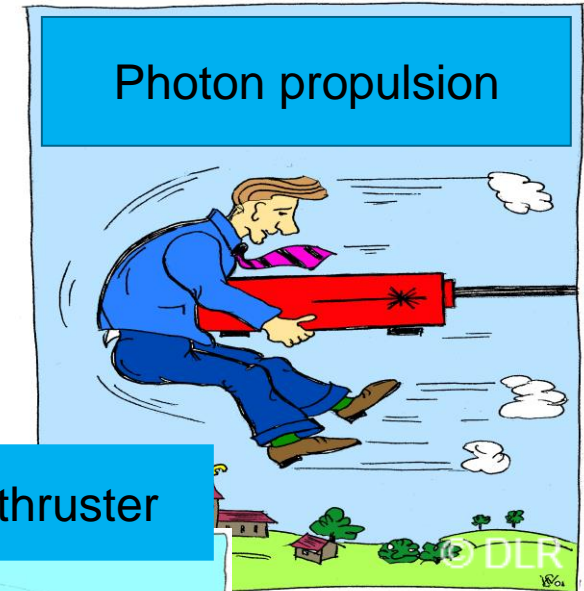

# Motivations for Laser Propulsion

Upload propulsion power in the order of **MW**

Reduce propellant consumption down to **< 1 %**

Precise satellite positioning at a level of **nm -  $\mu$ m**

Detect and remove space debris in the size range **cm - dm**

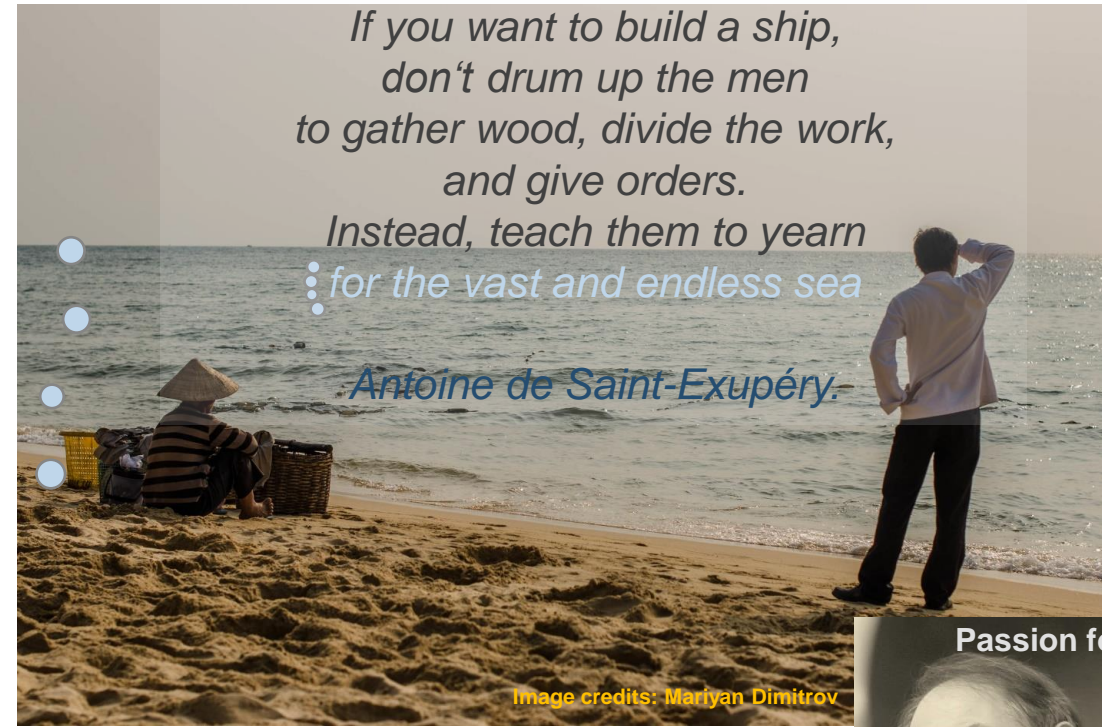

## Outline

Part I. Introduction

Part II. Lasers

Part III. Power beaming propulsion

Part IV. Laser launchers

Part V. Laser-ablative propulsion

Part VI. Spacecrafts' debris propulsion

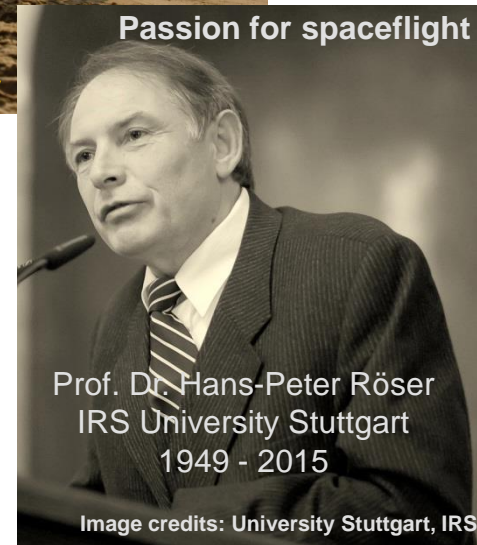

# Laser-matter Interaction Phenomena and Propulsion Principles



Part I. Introduction

Part II. Lasers

Part III. Power beaming propulsion

- Absorption and/or reflection  
→ Laser photon propulsion
- Absorption and conversion  
→ Laser photovoltaic propulsion
- Heating and ionization  
→ Laser-thermal propulsion

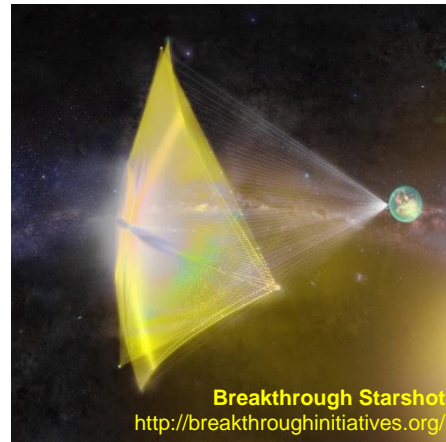

Part IV: Laser launchers

- Detonation and combustion  
→ Laser Lightcraft

Part V: Laser-ablative propulsion

- Material ablation

Part VI. Spacecrafts' debris propulsion

- Material ablation

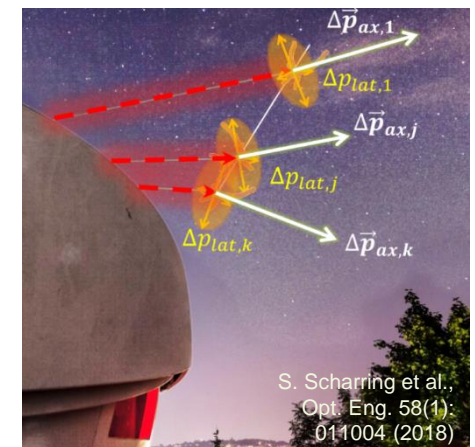
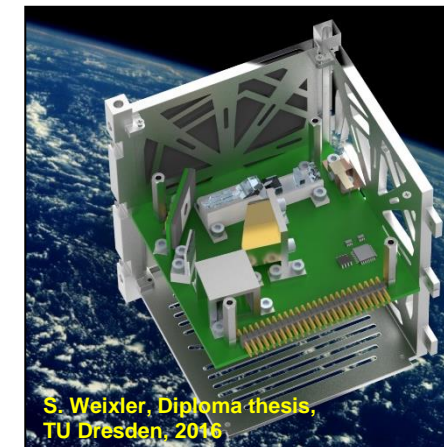
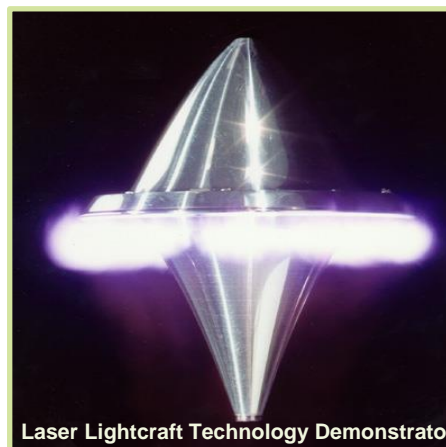

The background of the slide is a high-resolution photograph of a satellite in orbit above Earth. The satellite is a rectangular platform with two long, parallel solar panel arrays extending outwards. The panels are covered in a grid of small, square solar cells. The satellite's central body is complex, with various instruments and antennas visible. Below the satellite, the Earth's surface is visible, showing a mix of green landmasses and blue oceans, partially obscured by white clouds. The curvature of the Earth is clearly visible at the bottom of the frame.

# II. LASERS

The background of the slide is a high-resolution photograph of a satellite in orbit above Earth. The satellite is the central focus, featuring a central body with various instruments and two long, rectangular solar panel arrays extending outwards. The Earth's surface below is a mix of green landmasses and blue oceans, with white clouds scattered across the scene. The curvature of the planet is visible at the top and bottom edges of the frame.

# LIGHT AMPLIFICATION BY STIMULATED EMISSION OF RADIATION

# Laser Resonators

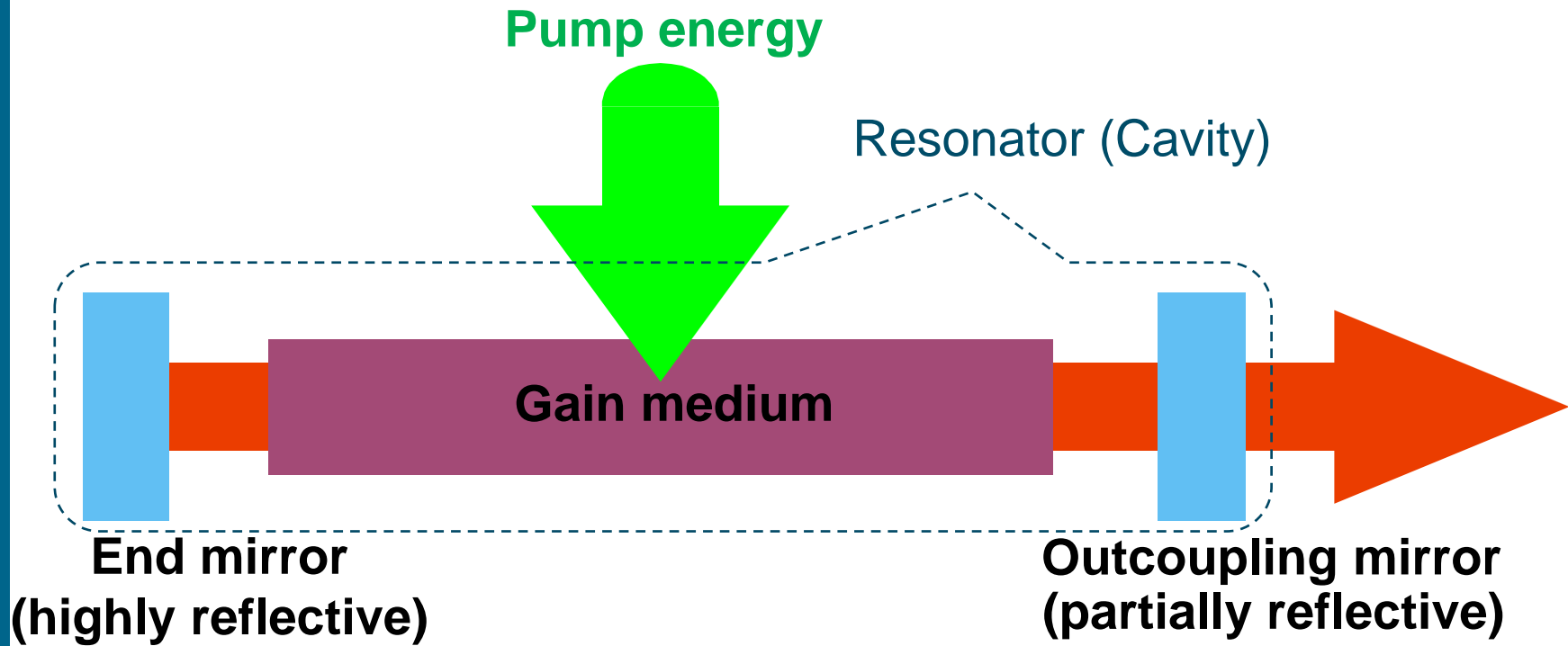

## Coherent light

Photons with identical

- frequency
- phase
- direction

→ **Superior focusability**

**Laser beam**

**Small-signal gain  $\gg$  absorption**

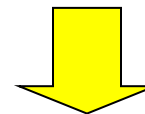

**Light amplification („Photon avalanche“)**

Image Credits:  
HU Berlin, Didaktik Physik

# Many music instruments are very similar to lasers

- Examples:
  - Clarinet
    - Resonator: Pipe
    - Active material: Reed
    - Pump: Breath
    - Output coupler: “Bell”
  - Ukulele
    - Resonator: String-fixations
    - Active material: String
    - Pump: Pick
    - Output coupler: Body



# Solid-State Lasers (SSL)

- **Laser-active ions (e.g., Neodymium, Ytterbium, Holmium)**
- **+ host material (e.g. glass, crystal, polymer)**
- **Original geometry: Rod-Type**
- Example: Nd:YAG
- (Neodymium-doped Yttrium aluminum garnet,  $\text{Nd:Y}_3\text{Al}_5\text{O}_{12}$ )
  
- **Pump mechanisms:**
  - Gas-discharge lamp
  - Laser diodes

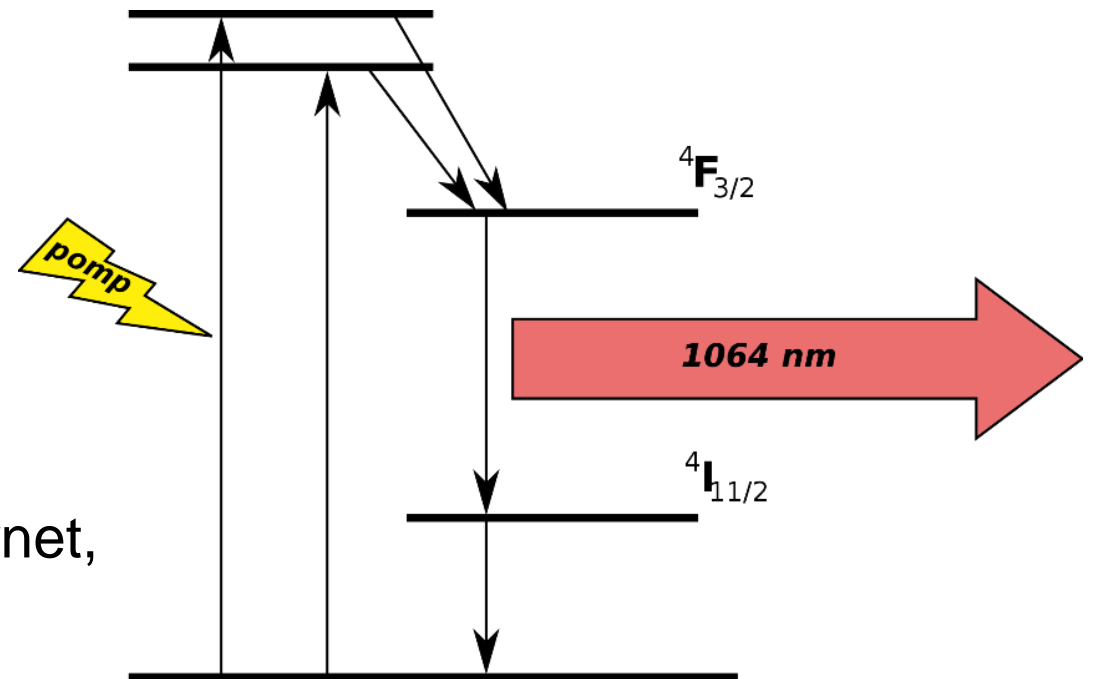

# SSL Geometries: Thin Disk Laser (improved cooling)

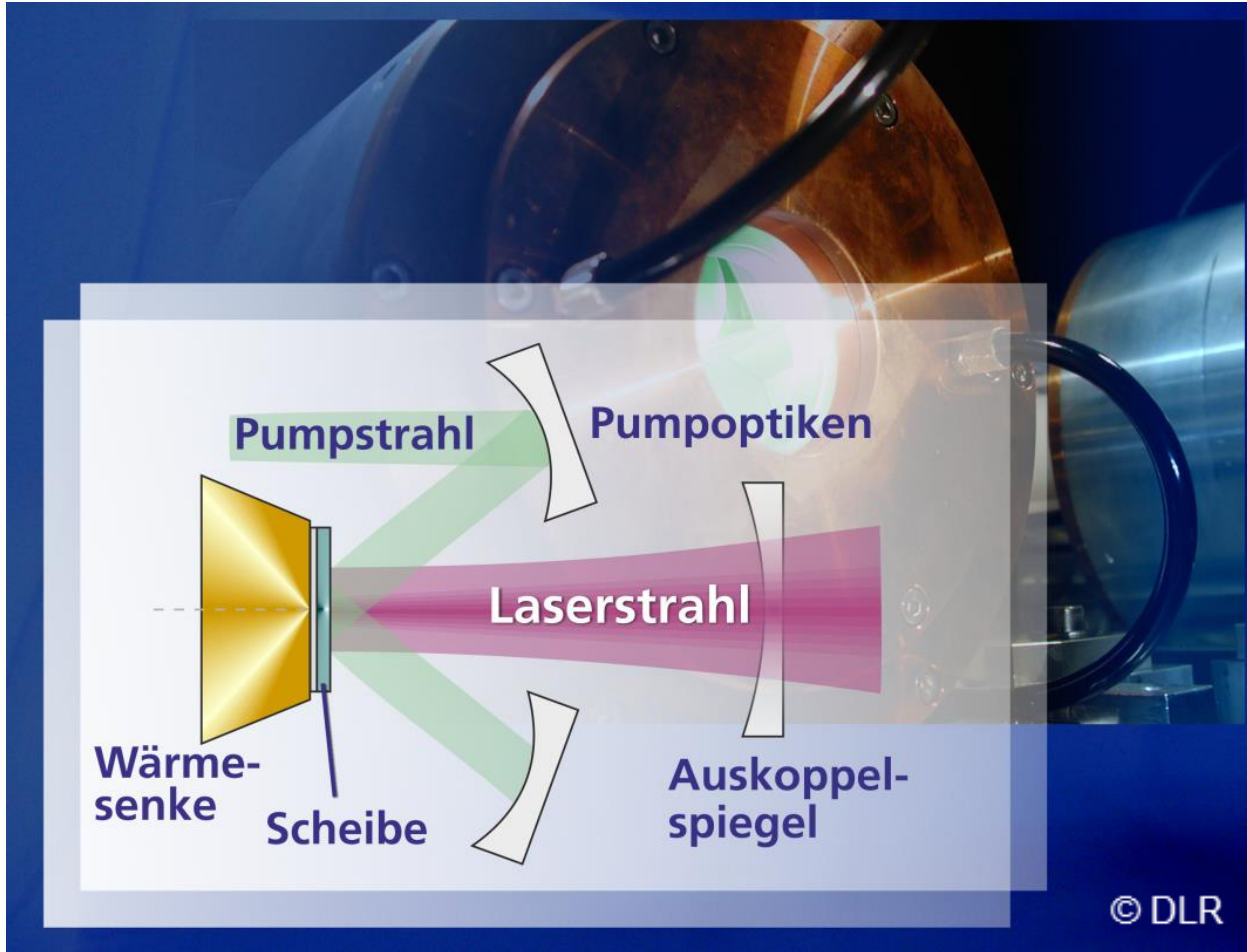

- Joint invention of DLR-TP / IFSW Uni Stuttgart
- Crystal disk, 100 – 200  $\mu\text{m}$  thin, e.g., Yb:YAG
- Pump modules: Laser diodes
- Continuous wave (cw) operation at the kW level
- Good power scalability
- Pulsed operation possible (ns, ps, fs)
- High beam brilliance (Power x beam quality)
- Current evolution: Wedged Thin Disk

# SSL Geometries: Fiber Laser (improved cooling)

- Up to high power > 10 kW
- Reduced complexity
- Difficulties:
  - Narrow frequency
  - Pulsed operation

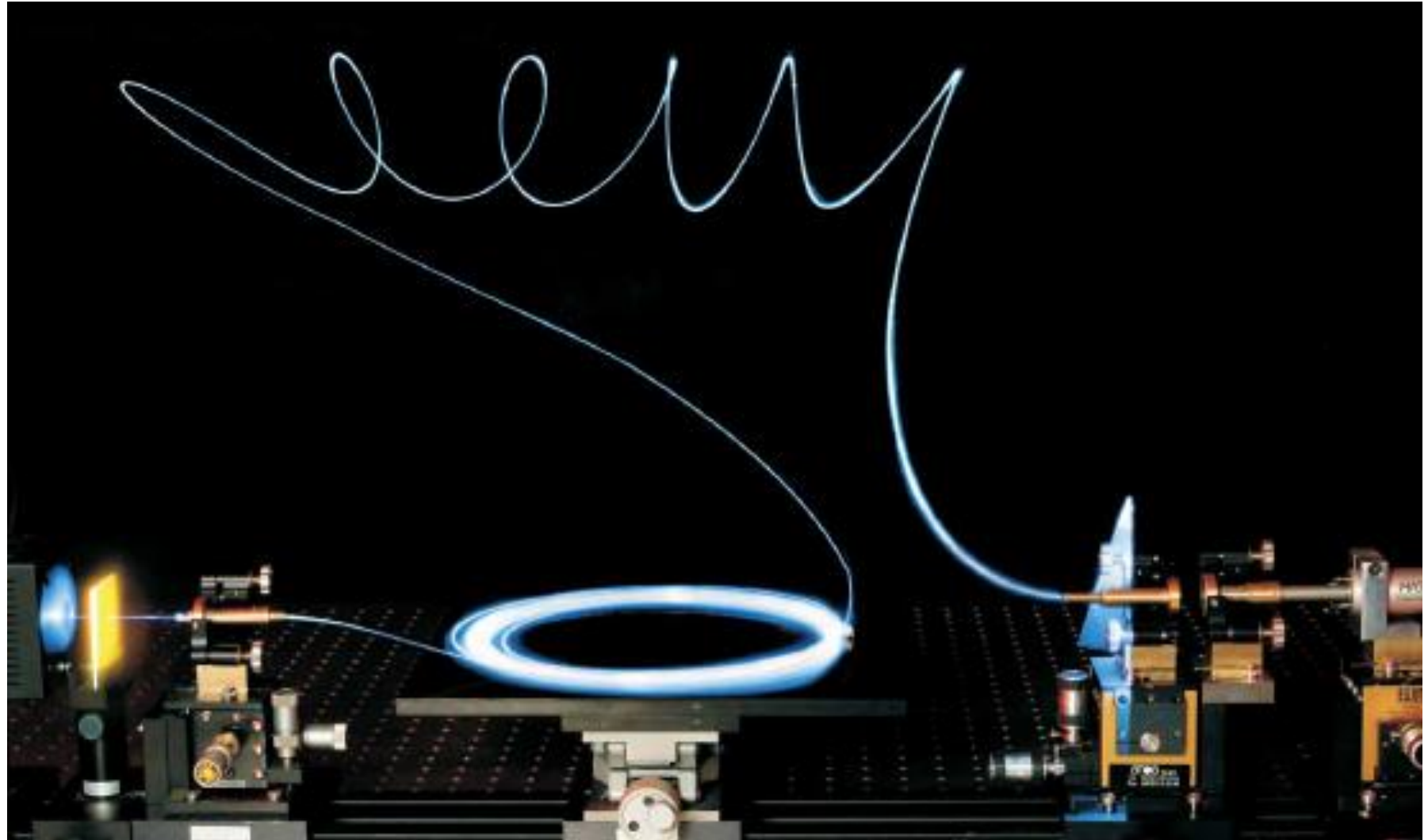

# CO<sub>2</sub> (gas) Laser Example

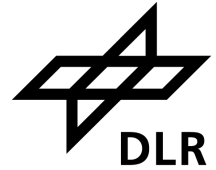

## Pump mechanisms:

Electrical discharge

Vibrational excitation of N<sub>2</sub> molecules by electron collisions

Energy transfer N<sub>2</sub> ⇒ CO<sub>2</sub>

Laser emission at  $\lambda = 9.6$  and  $10.6 \mu\text{m}$

Relaxation to ground state ⇒ heat

## Advantages:

Homogeneous profile of the refractive index

Cooling by gas recycling or

Admixing of helium

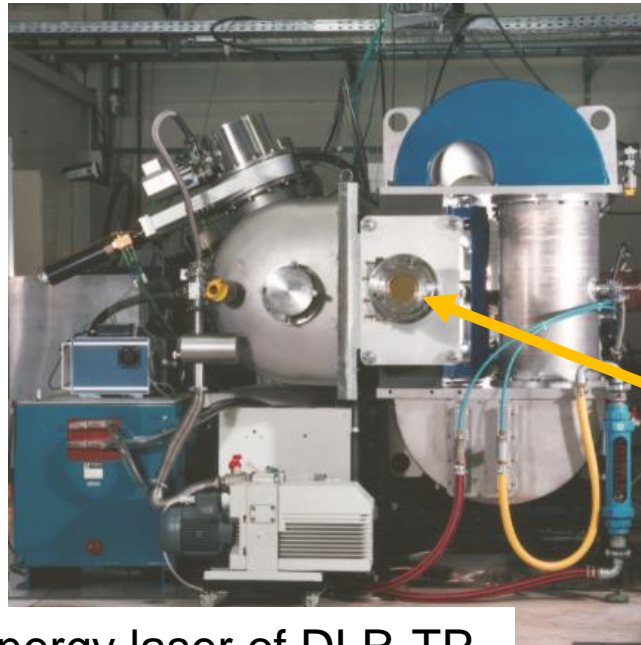

Former CO<sub>2</sub> high energy laser of DLR-TP

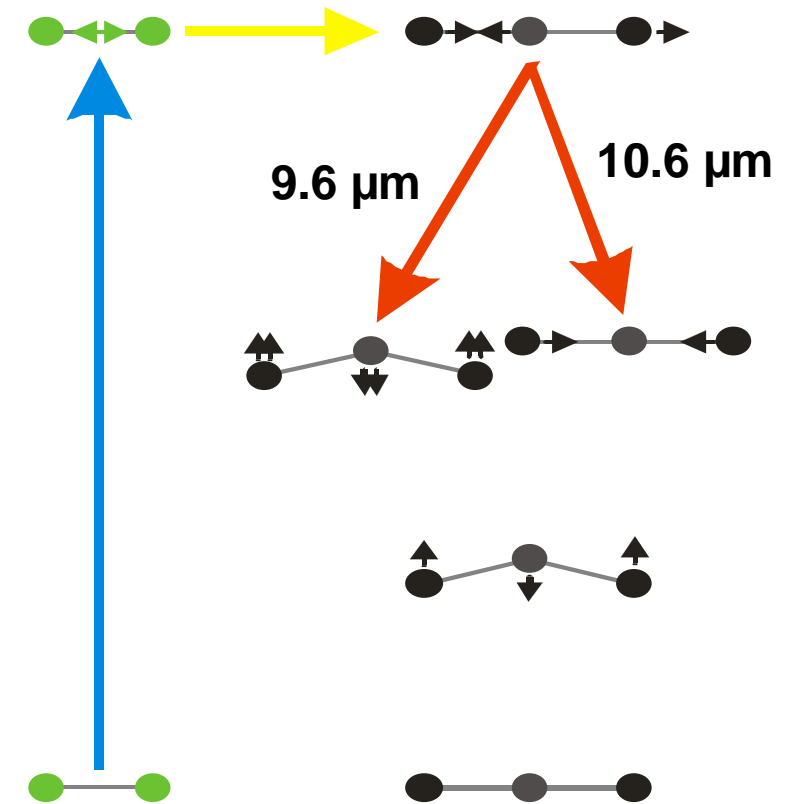

$\lambda = 10,6 \mu\text{m},$   
 $\tau = 7 - 10 \mu\text{s},$   
 $f = 0 - 50 \text{ Hz},$   
 $d \approx 80 \text{ mm},$   
 $E_L = 30 - 210 \text{ J}$   
 $\bar{P} = 0 - 7,5 \text{ kW}$   
 $\theta \approx 13 \text{ mrad}$

# Laser Light: Properties

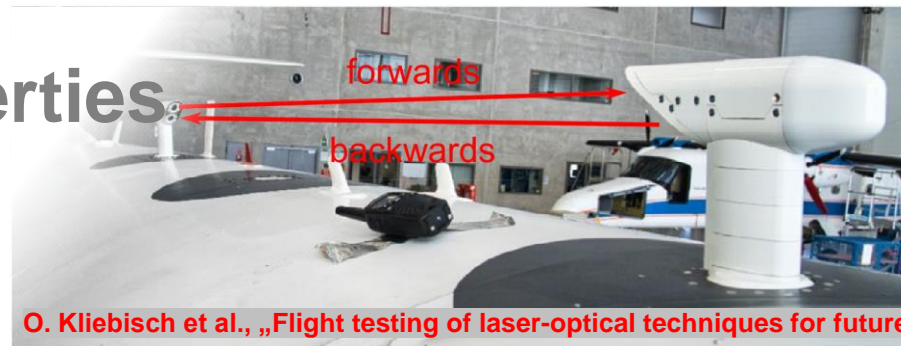

O. Kliebisch et al., „Flight testing of laser-optical techniques for future optical air data sensors.”



- Coherence: Photons sharing the same...

- ... frequency



- ... phase



- ... direction



- ... position



- ... time



- ... polarization



- ... can be applied in

- ... spectroscopy

- ... interferometry

- ... optical communication and power beaming

- ... 3d-laser-scanning-microscopy

- ... local material processing

- ... material analysis



Image credits:  
Ascending Technologies

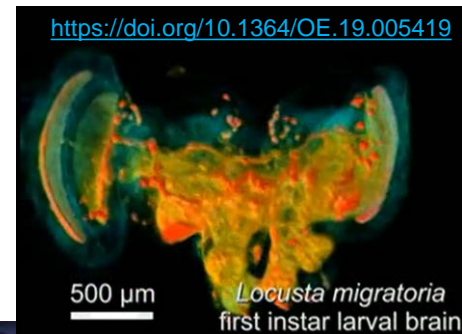

<https://doi.org/10.1364/OE.19.005419>

500  $\mu\text{m}$   
*Locusta migratoria*  
first instar larval brain



Image credits:  
Quander Metall- und Lasertechnik

# Focusability

## Sun

- Archimedes heat ray
- Defeat of the Roman fleet
- Syracuse, 212 BC



Image credits: Massachusetts Institute of Technology



## Gaussian laserbeam

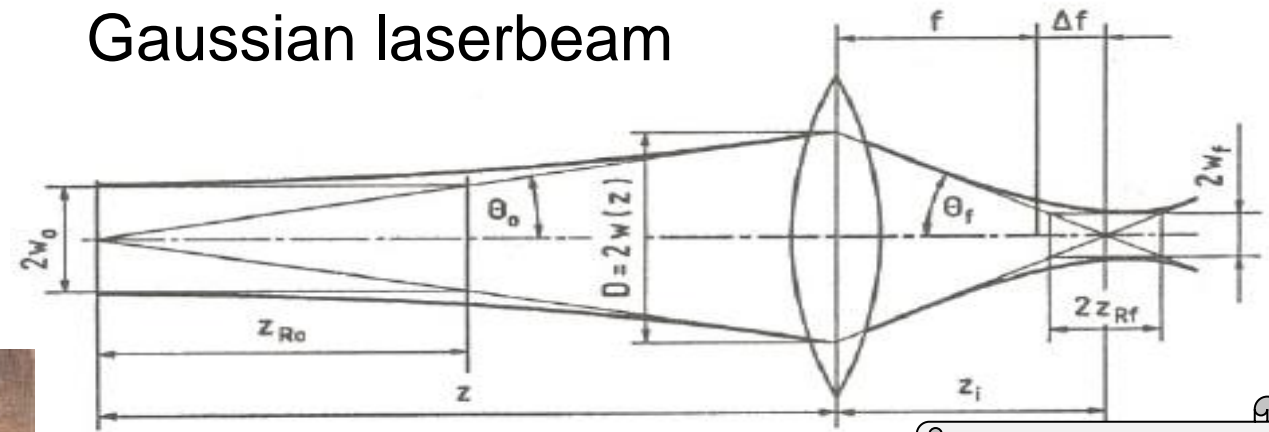

H. Hügel, Strahlwerkzeug  
Laser, Teubner-Verlag  
1992, Stuttgart

**Beam parameter product:**

$$w_0 \Theta_0 = w_f \Theta_f = \frac{\lambda \cdot M^2}{\pi}$$

$\lambda$ : Laser wavelength

$w$ : Beam radius

$\Theta$ : Divergence angle

$M^2$ : Beam quality parameter

# Laser Operating Range

$$R = c_{opt} \sqrt{Str} \frac{D \cdot d}{\lambda}$$

$\lambda$ : Laser wavelength

$D$ : Transmitter diameter

$d$ : Receiver diameter

$c_{opt}$ : optical correction factor (0.22...0.29)

$Str$ : Strehl number

- typically 0.3 – 0.5
- incorporates beam quality and
- optical components

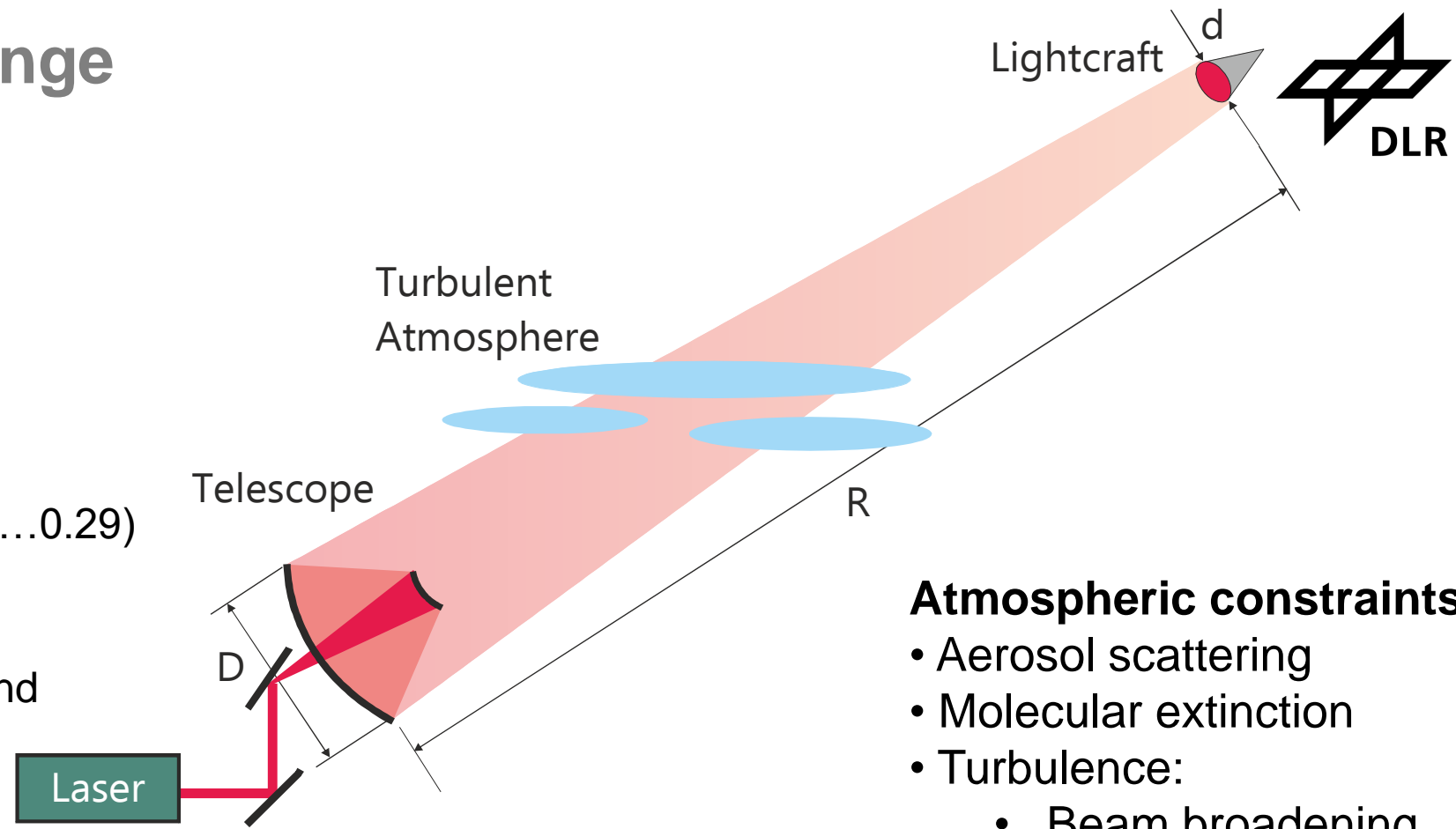

## Atmospheric constraints:

- Aerosol scattering
- Molecular extinction
- Turbulence:
  - Beam broadening
  - Beam wander
- Thermal blooming

Example:  $D = 5\text{m}$ ,  $d = 1\text{m}$ ,  $Str = 0.5$

Laser	$\lambda$ , $\mu\text{m}$	R, km
CO <sub>2</sub>	10,6	137
COIL	1,32	1103
Nd:YAG 2f	0,53	2736



H.-A. Eckel et al., *Concept for a Laser Propulsion Based Nanosat Launch System*, AIP Conf. Proc. **702**, 263 – 273 (2004), DOI: 10.1063/1.1721006

A satellite with large solar panels is shown in orbit above Earth. The satellite is a rectangular platform with two long arms extending outwards, each carrying a series of solar panels. The Earth's surface is visible below, showing green landmasses and blue oceans, with a thin white cloud layer. The curvature of the Earth and the blackness of space are also visible.

# III. POWER BEAMING PROPULSION

# Power Beaming Propulsion

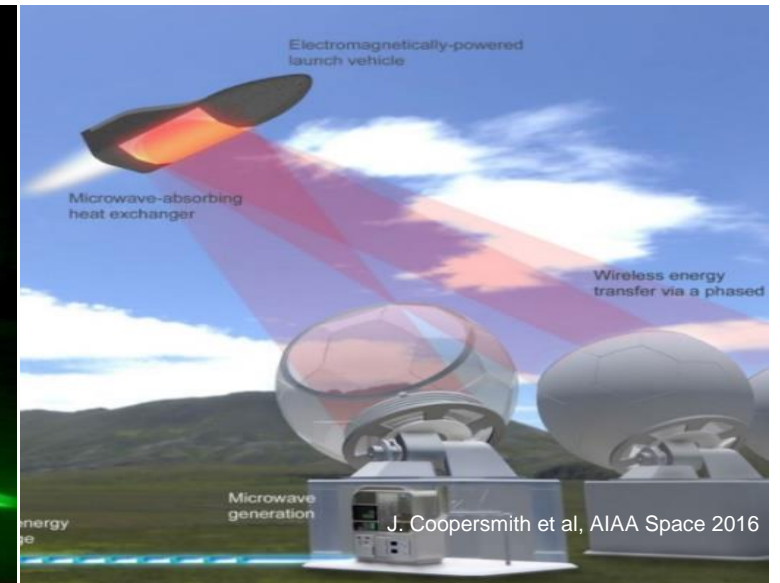
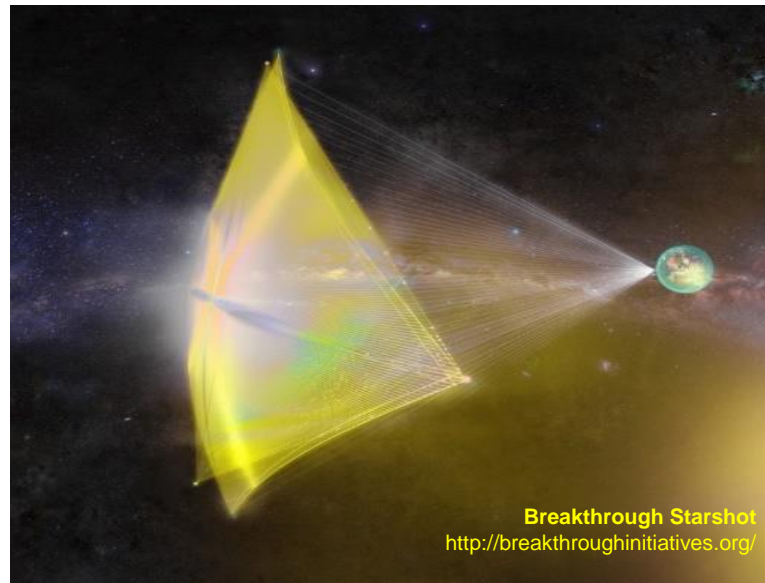

- Absorption and/or reflection  
→ Laser photon propulsion  
→ Intra-cavity photon propulsion
- Absorption and conversion  
→ Laser photovoltaic propulsion
- Heating and ionization  
→ Laser-thermal propulsion

# Photon propulsion: Main interaction mechanisms...

$$E_{\text{Photon}} = h\nu \quad m_{\text{Photon}} = 0 \quad p_{\text{Photon}} = \frac{h\nu}{c}$$

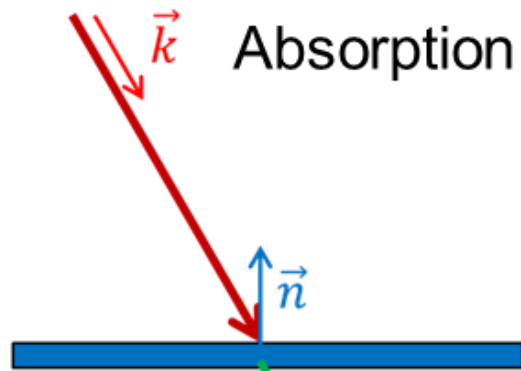

$$\vec{F} = A \cdot \frac{P_L}{c} \hat{k}$$

$$c_m = A \cdot 3.3 \text{ nN/W}$$

Diffuse reflection

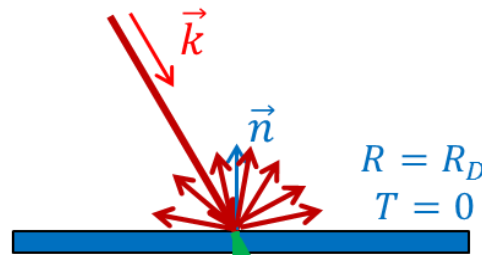

$$\vec{F} = \left( \hat{k} - \frac{1}{2} \cdot \hat{n} \right) \cdot R_D \frac{P_L}{c}$$

Specular reflection

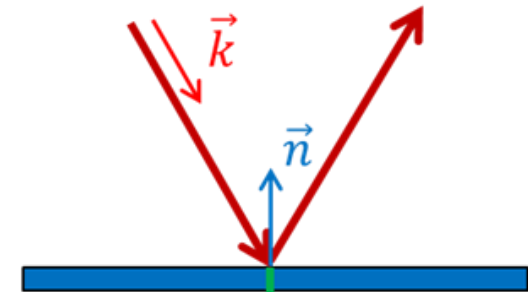

$$\vec{F} = -2R \cos \vartheta \frac{P_L}{c} \hat{n}$$

$$c_m = 2R \cos \vartheta \cdot 3.3 \text{ nN/W}$$

$$A + R + R_D + T = 1$$

$$\vec{F} = \frac{P_L}{c} \left[ (A + R_D) \hat{k} - (R_D/2 + 2R \cos \vartheta) \hat{n} \right]$$

# Breakthrough Starshot...



## Mission

- Destination  $\alpha$  Centauri
- Propulsion: Photon pressure
- Example acceleration: 70 GW, 10x10 km, 10 minutes, 20,000 g, to 0.26 c after the moon.
- Funding: initially 100 M\$; intended: 40 B\$, 40 years

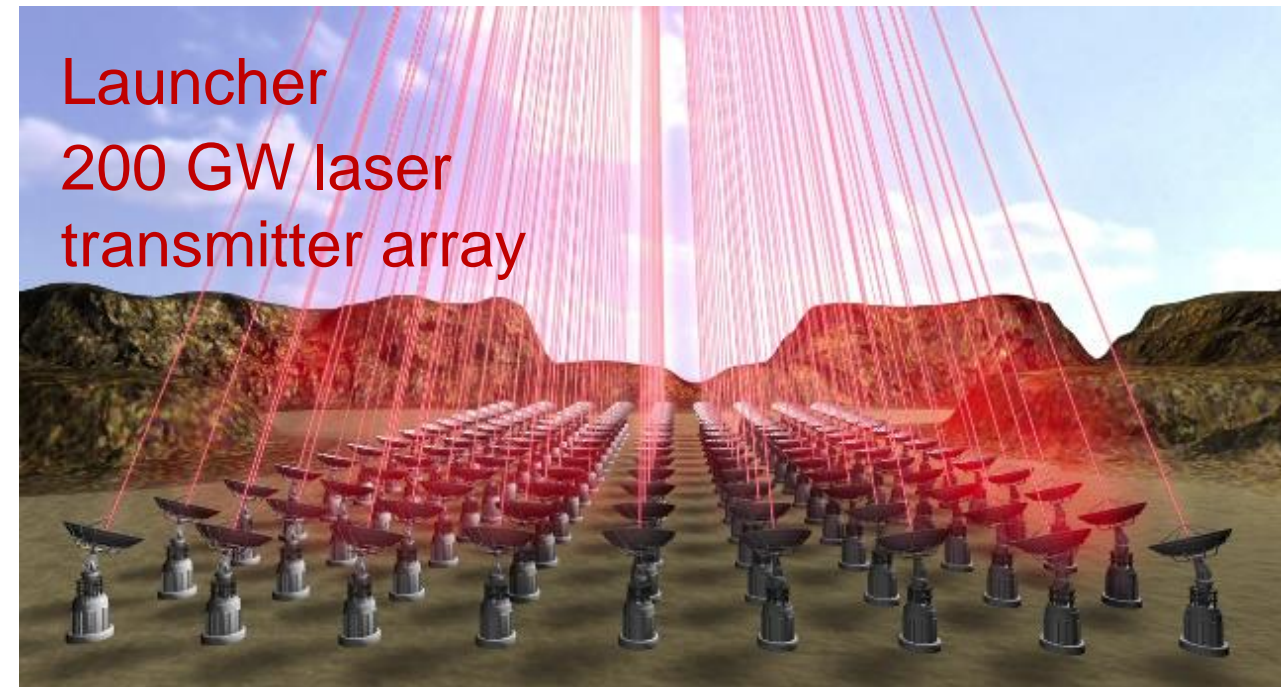
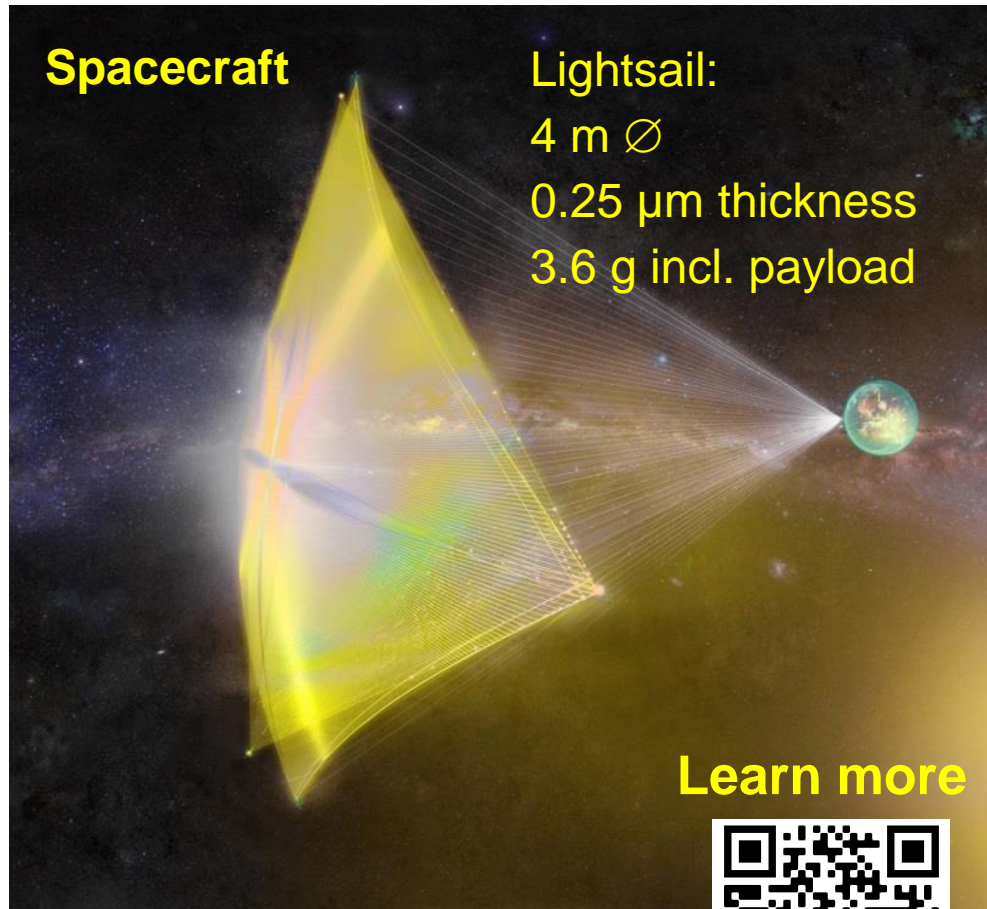

Philip Lubin, "A Roadmap to Interstellar Flight", <https://arxiv.org/pdf/1604.01356>

# Digression: Thrust Balance Calibration using Photon Pressure

## Extra-cavity

- Laser:  
1 kW thin disk laser
- HR =  
highly reflective (99.98%)
- Incidence angle:  $10^\circ$

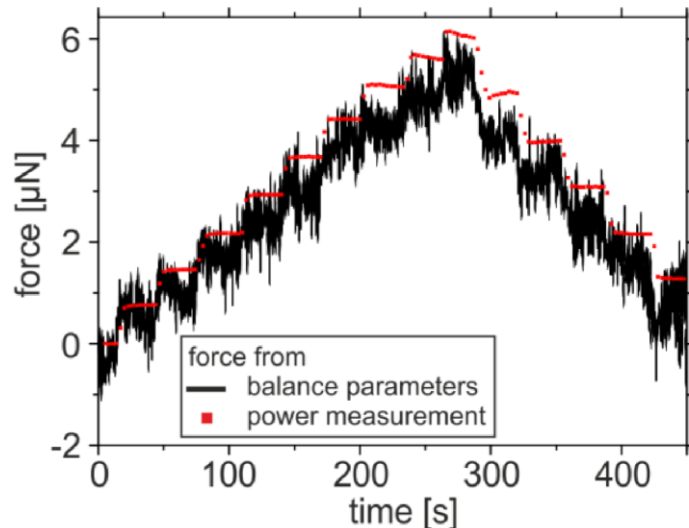
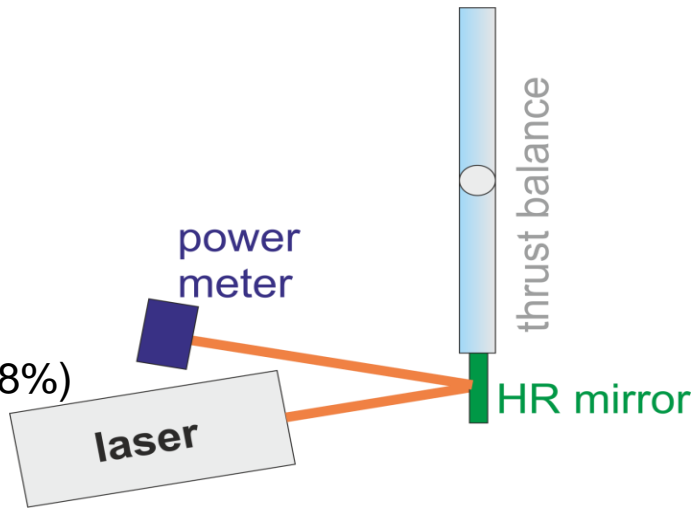

## Intra-cavity

- Output coupler:  
2.4% transmittance

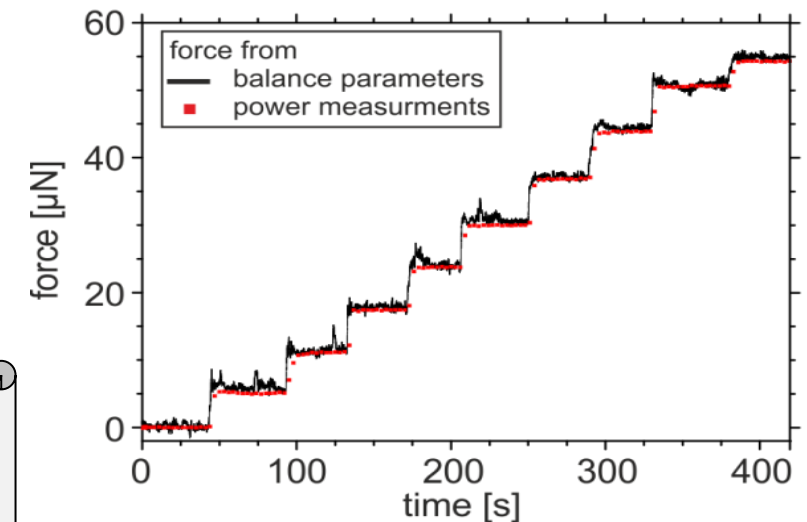
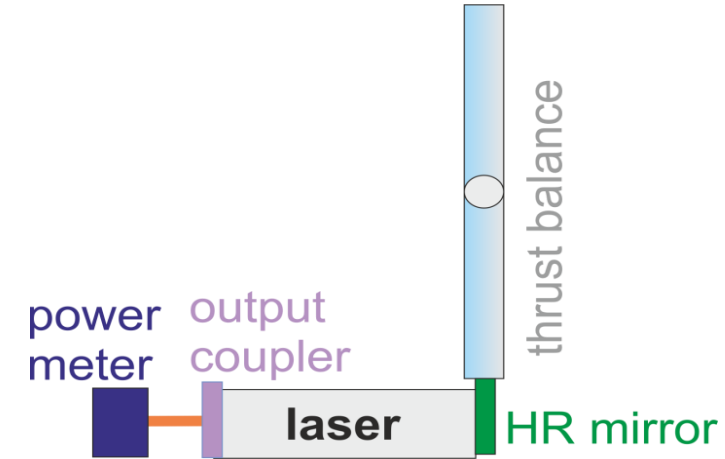

S. Karg et al., Laser Propulsion Research Facilities at DLR Stuttgart, Symposium on High Power Laser Ablation / Beamed Energy Propulsion 2014

# Laser-powered Space Elevator

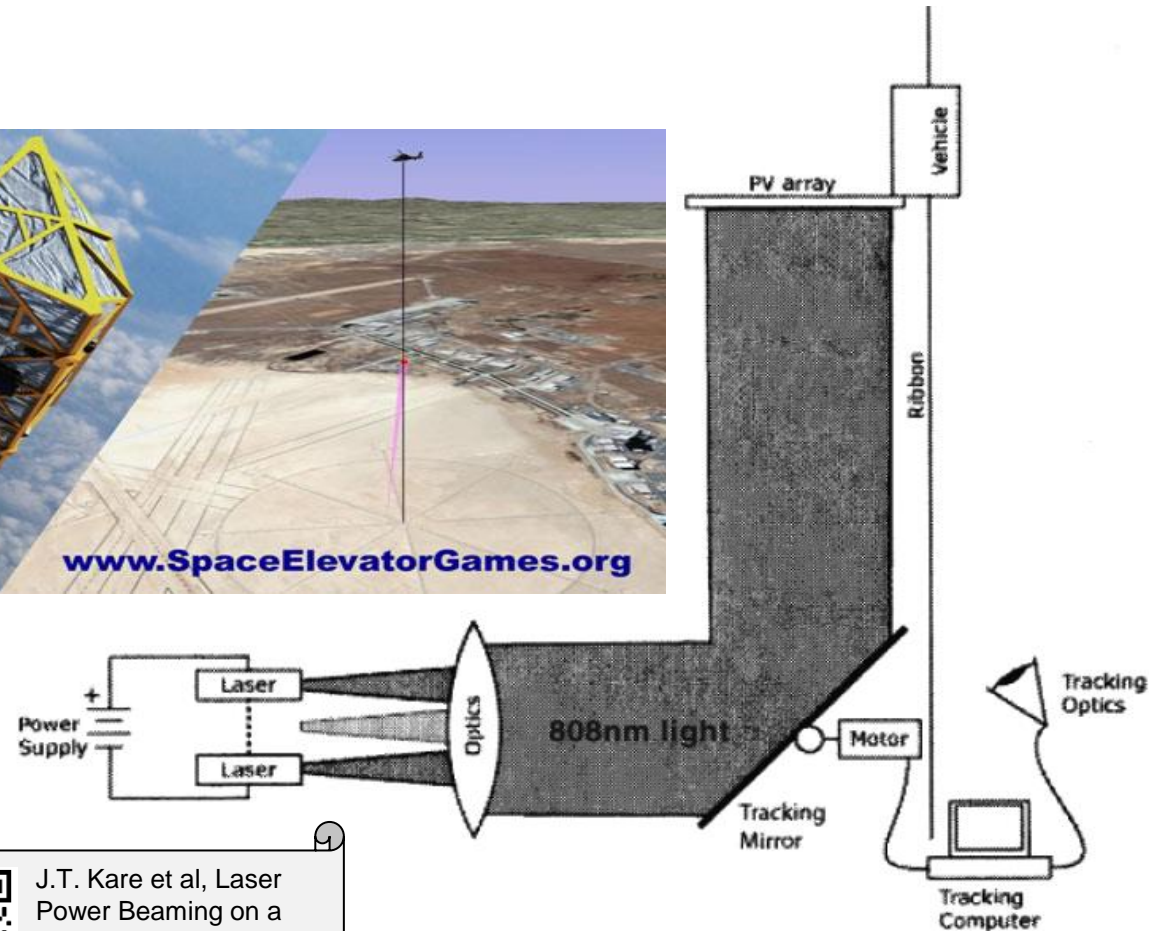

J.T. Kare et al, Laser Power Beaming on a Shoestring, AIP Conf. Proc. 997, 97-108 (2008), DOI: 10.1063/1.2931935



B.C. Edwards, The Space Elevator: an Ideal Application for the Free Electron Laser, Proc. SPIE 4632, 134 (2002), DOI: 10.1117/12.469764



# Beamed Energy: Thermal Propulsion – General Remarks



J. Coopersmith et al., A Strategic Roadmap for Commercializing Low-Cost Beamed Energy Propulsion Launch Systems, AIAA Space 2016, DOI:10.2514/6.2016-5555

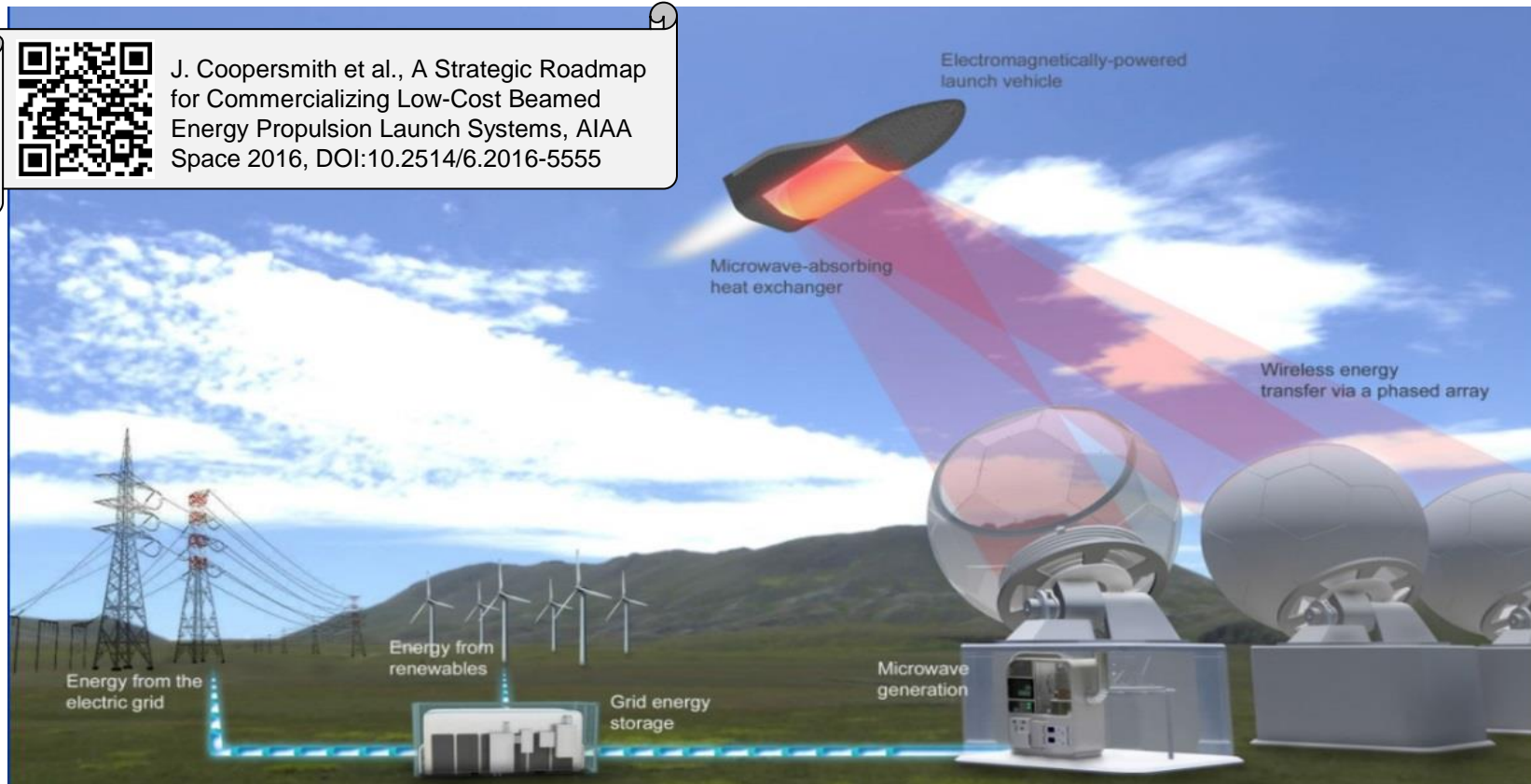

## Propulsion principle:

- Remotely based high power laser (or microwave) source (cw or pulsed)
- Propellant heating by focused beam
- Jet expansion and thrust generation

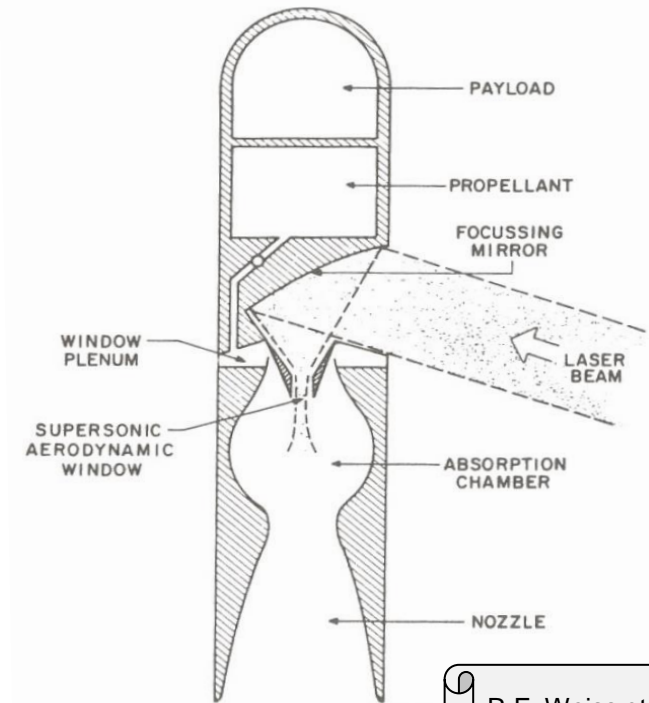

R.F. Weiss et al., Laser Propulsion, Astronautics and Aeronautics, March 1979: 50 – 58

## Special laser-thermal propulsion concepts:

- Detonation and combustion → Laser Lightcraft (Part IV)
- Material ablation → Laser-ablative propulsion (Part V)  
→ Space debris propulsion (Part VI)

# Energy Conversion Efficiencies in remotely-powered Laser Propulsion



$$E_{kin} = 1/2 mv^2 = \eta_{prop} \psi^{-1} \alpha \beta \gamma \delta \cdot E_{wall}$$



*Propulsion efficiency*



**Spacecraft kinetic energy**

**Energy coupling to spacecraft**

*Mechanical efficiency*

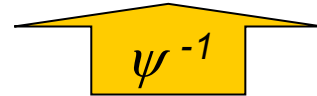

**Jet kinetic energy**

*Expansion efficiency*

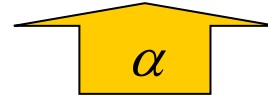

**Propellant inner energy**

*Energy absorption efficiency*

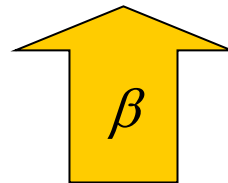

*if applicable:  
Detonation  
Combustion*

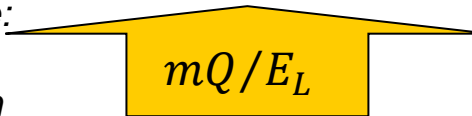

**Laser pulse energy incident at the propellant**

*Transmission efficiency*

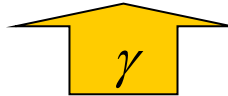

**Initial laser pulse energy**

*Electro-optical conversion efficiency*



The background of the slide is a high-resolution photograph of a satellite in orbit above Earth. The satellite is a rectangular platform with two long, parallel solar panel arrays extending outwards. The panels are covered in a grid of small, square solar cells. The satellite's main body is centrally located between the panels and features various instruments, antennas, and a large cylindrical component. Below the satellite, the Earth's surface is visible, showing a mix of green landmasses and blue oceans, with a thin white layer of clouds. The curvature of the Earth is clearly visible on the right side of the image.

# IV. LASER LAUNCHERS

# Laser Launchers

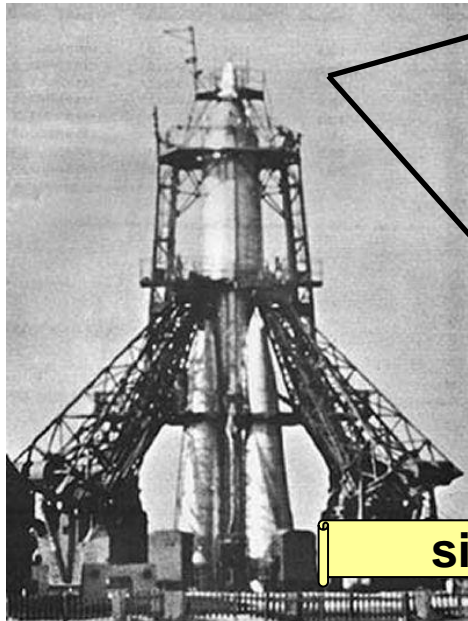

Payload: Sputnik-I  
83,6 kg, 58 cm

**Intercontinental missile**  
**280 t, 34 m**

since 1957

75 years of R&D?

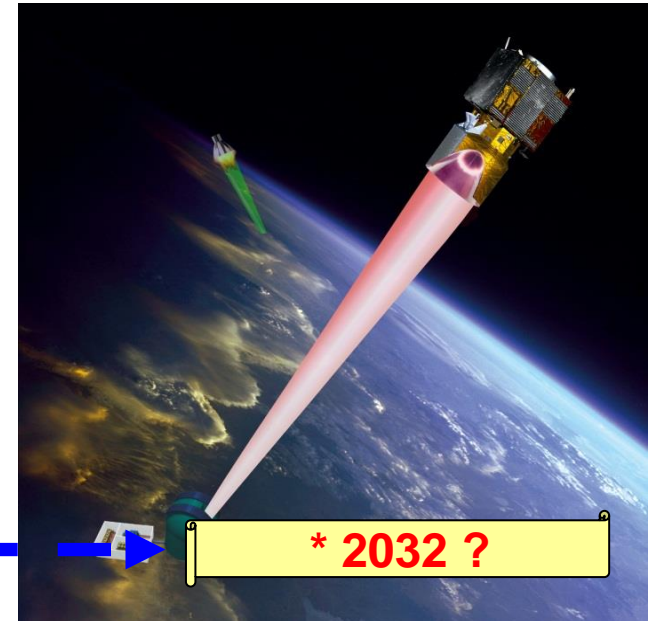

\* 2032 ?



since 1804

75 years of R&D



\* 1879

# Parabolic Lightcraft („Bohn Bell“)

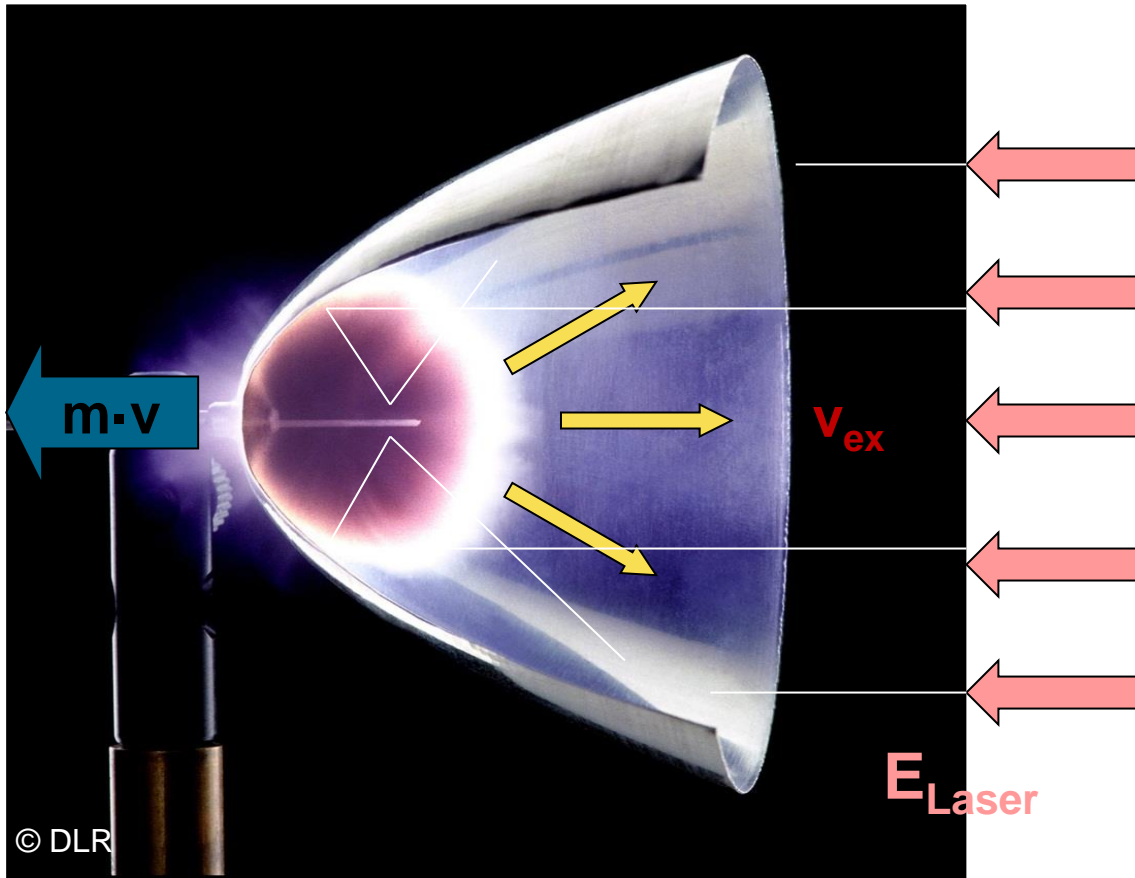

**Air Plasma**

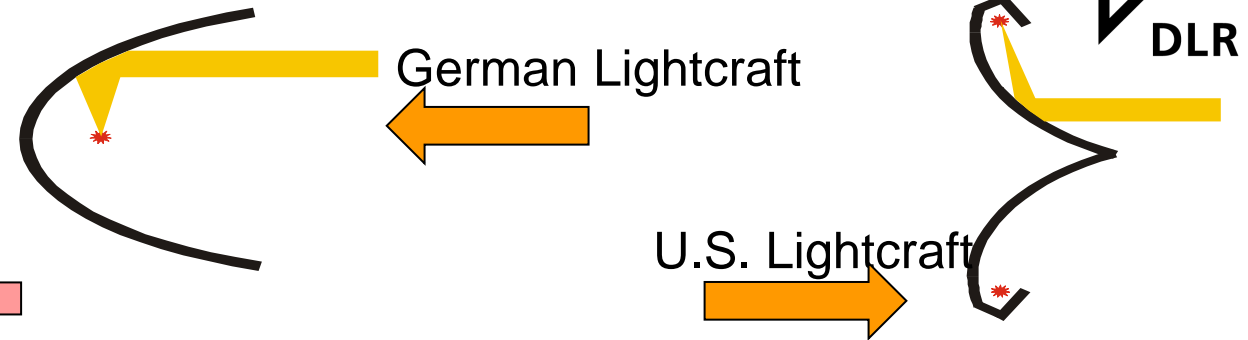

Laser pulse energy: 20 ... 200 J  
 Pulse duration: ~ 8 ... 12  $\mu$ s

- ⇒ Focus intensity >  $10^7$  W/cm<sup>2</sup>
- ⇒ Plasma ignition
- ⇒ Rapidly expanding plasma
- ⇒ Momentum transfer by increased pressure and gas exhaust (air/propellant)

# Lightcraft Technology Demonstrator

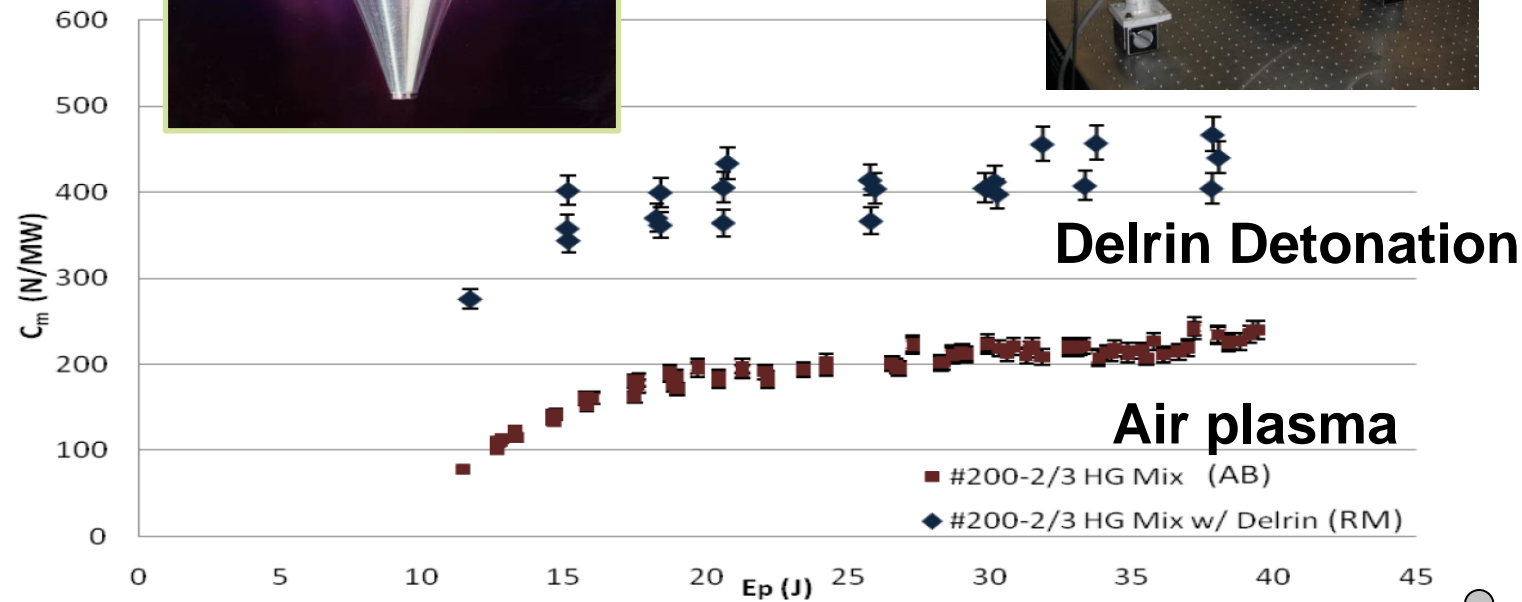

Watch on  
YouTube

$m = 50,6 \text{ g}$   
 $\bar{P}_{opt} = 10 \text{ kW}$   
 $f_{spin} = 10000 \text{ rpm}$   
 $z_{max} = 71 \text{ m}$

Image Credits: Leik Myrabo



D.A. Kenoyer et al, Axial Impulse Generation of Lightcraft Engines with  $\sim 1 \mu\text{s}$  Pulsed TEA  $\text{CO}_2$  Laser, AIP Conf. Proc. **1402**: 82 – 92 (2011), DOI: 10.1063/1.3657018



L.N. Myrabo, World Record Flights of Beam-Riding Rocket Lightcraft: Demonstration of „Disruptive Propulsion Technology“, AIAA Paper 2001-3798, DOI: 10.2514/6.2001-3798

# Altitude Simulation (no propellant)

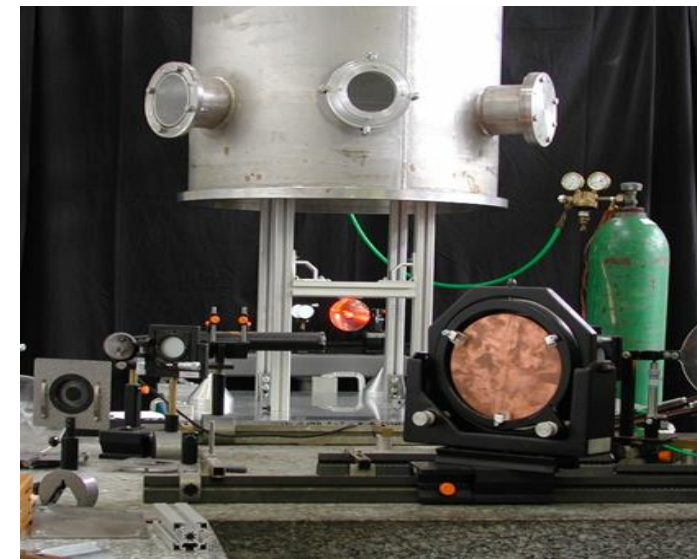
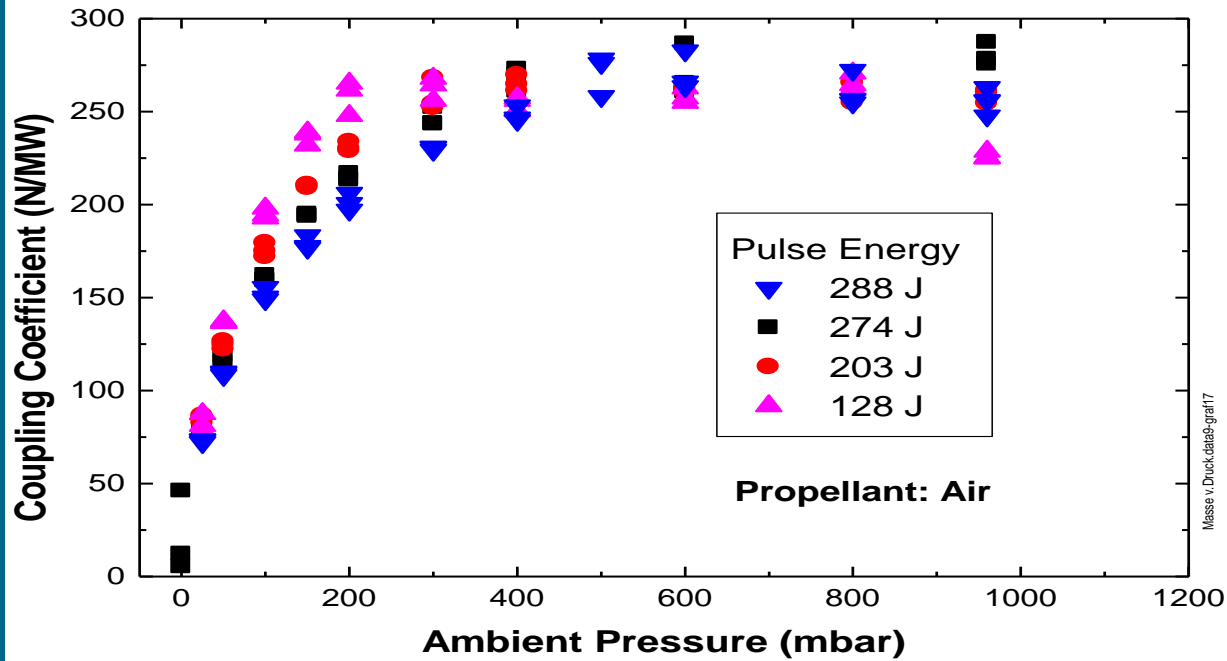

Ballistic pendulum in vacuum chamber

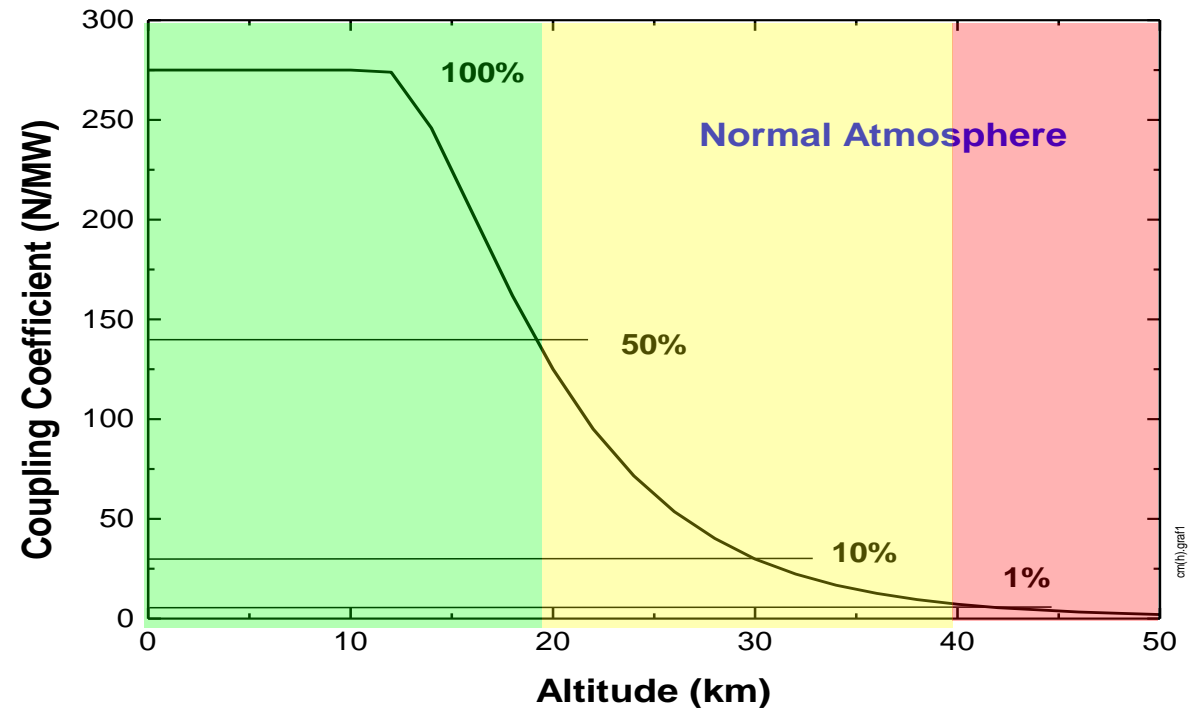

# Altitude Simulation (with Propellant)

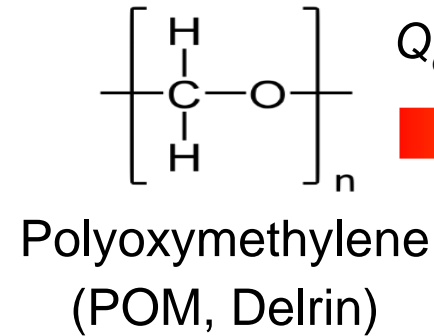
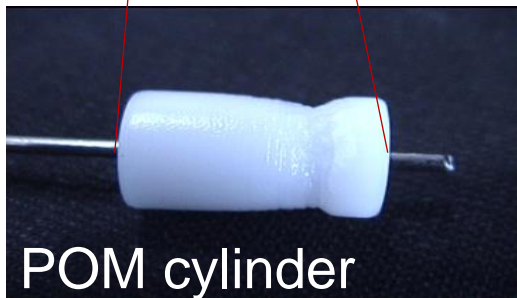
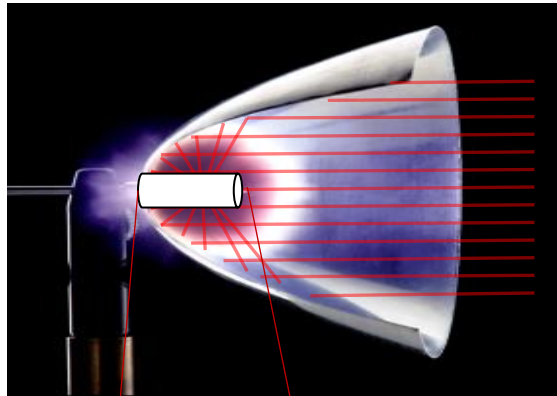

$$Q_{det} = 2.69 \text{ J/mg}$$

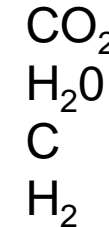

$$Q_{db} = 16.1 \text{ J/mg}$$

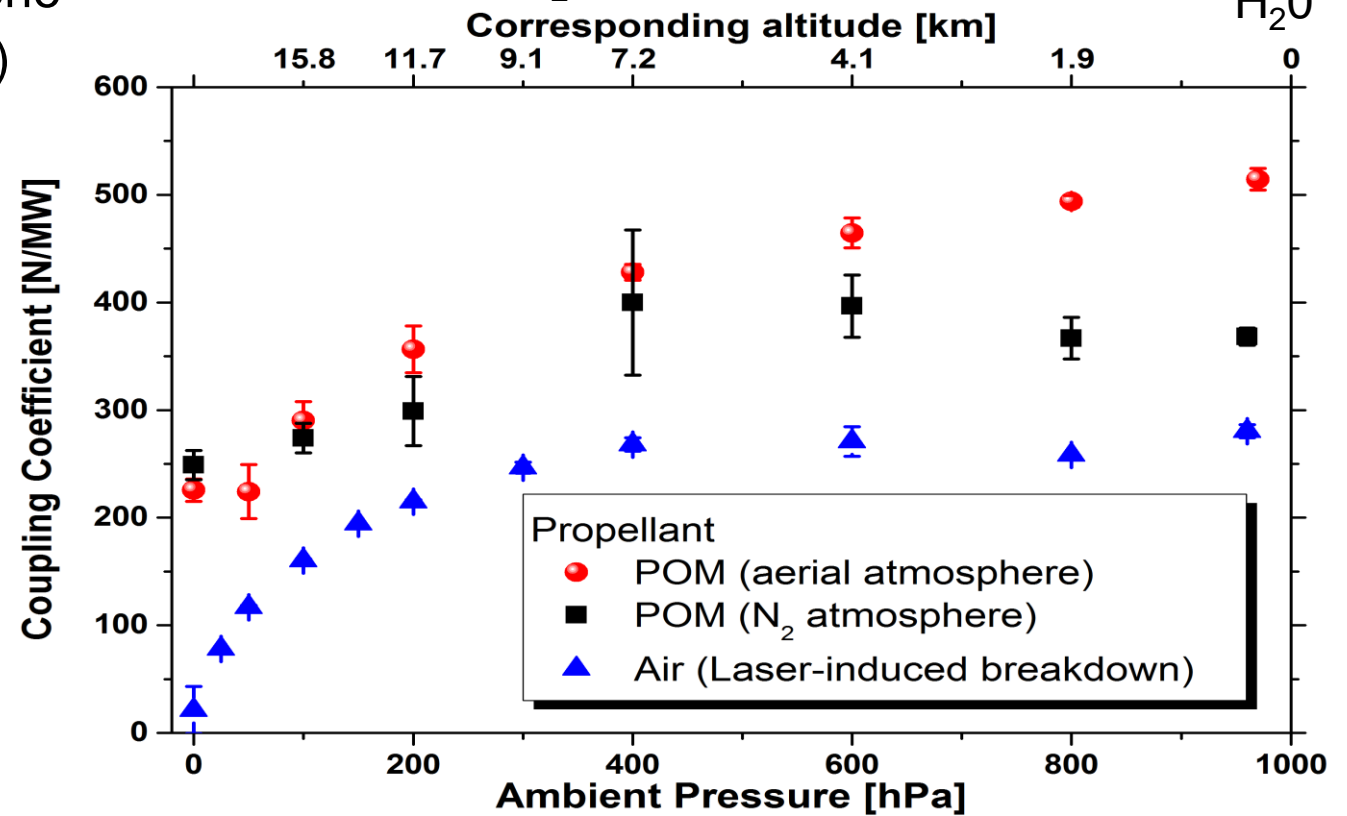
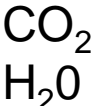

# Propellant Detonation



Internal efficiency of pure ablation (cf. Part V):

$$\eta_{abl} = 1/2 c_m \cdot v_{jet} = \alpha \beta$$

$\alpha$  Expansion efficiency  
 $\beta$  Absorption efficiency

Internal efficiency of exothermal reactions:

$$\eta_{ex} = \alpha (\beta + m Q/E_L)$$

$Q$  Specific heat of reaction  
 $E_L$  Laser pulse energy

with:

$$Q = Q_{det} + N_{db} Q_{db}$$

$Q_{det}$  Specific detonation energy  
 $N_{db}$  Fraction of delayed burning  
 $Q_{db}$  Specific energy of combustion

Detonation and combustion of CHO polymers

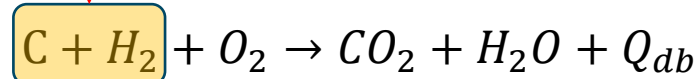
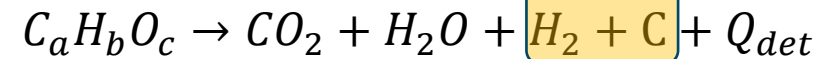

Example: Polyoxymethylene (Delrin, POM)

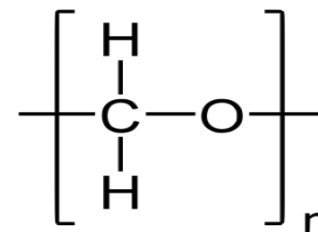

$$Q_{det} = 2,69 \text{ J/mg}$$

$$Q_{db} = 16,1 \text{ J/mg}$$



A.A. Ageichik et al, Detonation of CHO Working Substances in a Laser Jet Engine, Technical Physics **54**: 402 (2009), DOI: 10.1134/S1063784209030128

# Free-flight Experiments (no Spin)

Fig. 5. Time–altitude curves of five flights each of a parabolic lightcraft during a laser burst of 10 pulses,  $P_L = 2.9\text{ kW}$  averaged, (a) without ignition pin,  $m_{LC} = 45.6\text{ g}$ , and (b) with ignition pin,  $m_{LC} = 49.3\text{ g}$ .

200 N/MW – 600 mN –  $2\text{ m/s}^2$

## Without ignition pin

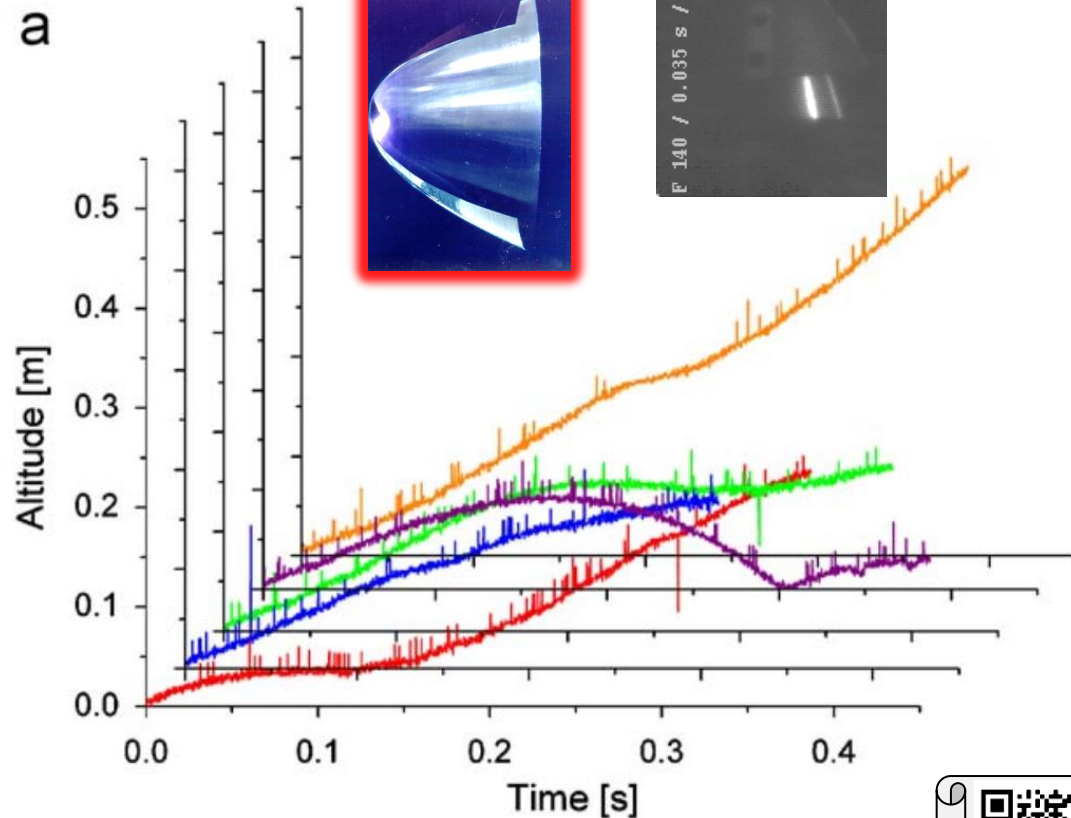

## With ignition pin

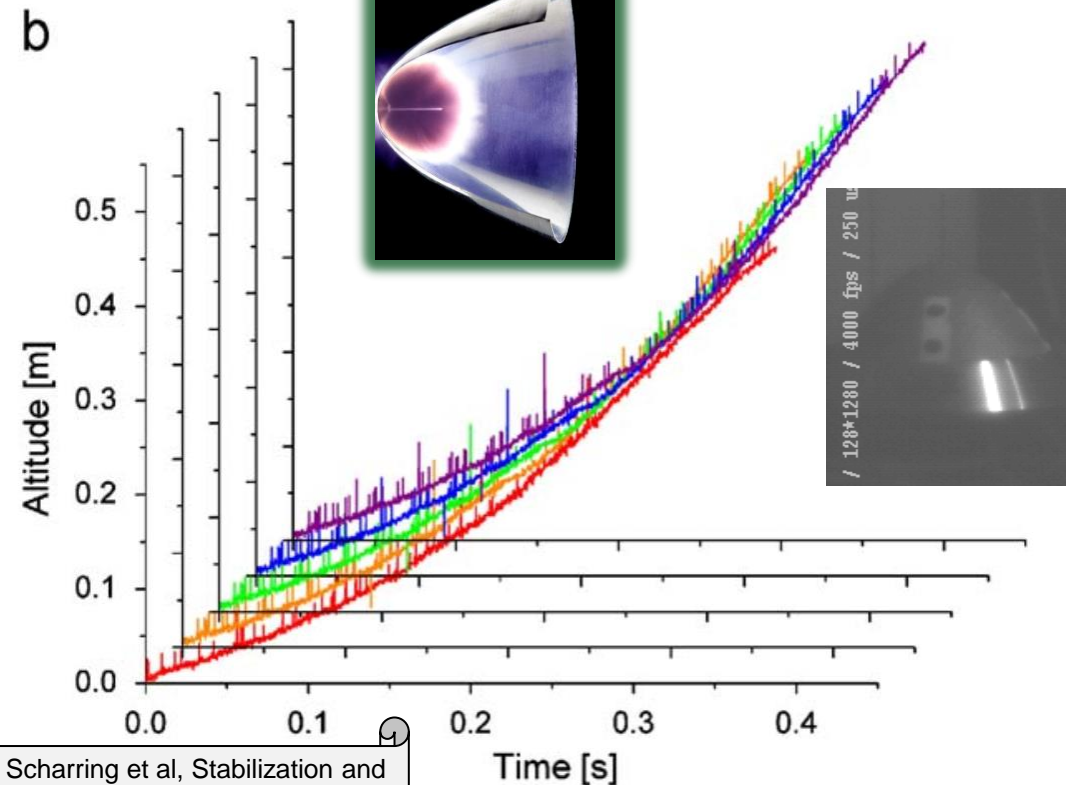

S. Scharring et al, Stabilization and steering of a parabolic laser thermal thruster with an ignition device, Acta Astronaut. **65(11-12)**: 1599 (2009), DOI:10.1016/j.actaastro.2009.04.007

The background of the slide is a high-resolution photograph of a satellite in orbit above Earth. The satellite is a rectangular platform with two long, multi-panel solar arrays extending horizontally from its central body. The Earth's surface below is a mix of green landmasses and blue oceans, with white clouds scattered across the scene. The curvature of the planet is visible at the top and bottom edges of the frame.

# V. LASER-ABLATIVE PROPULSION

# A Thought Experiment

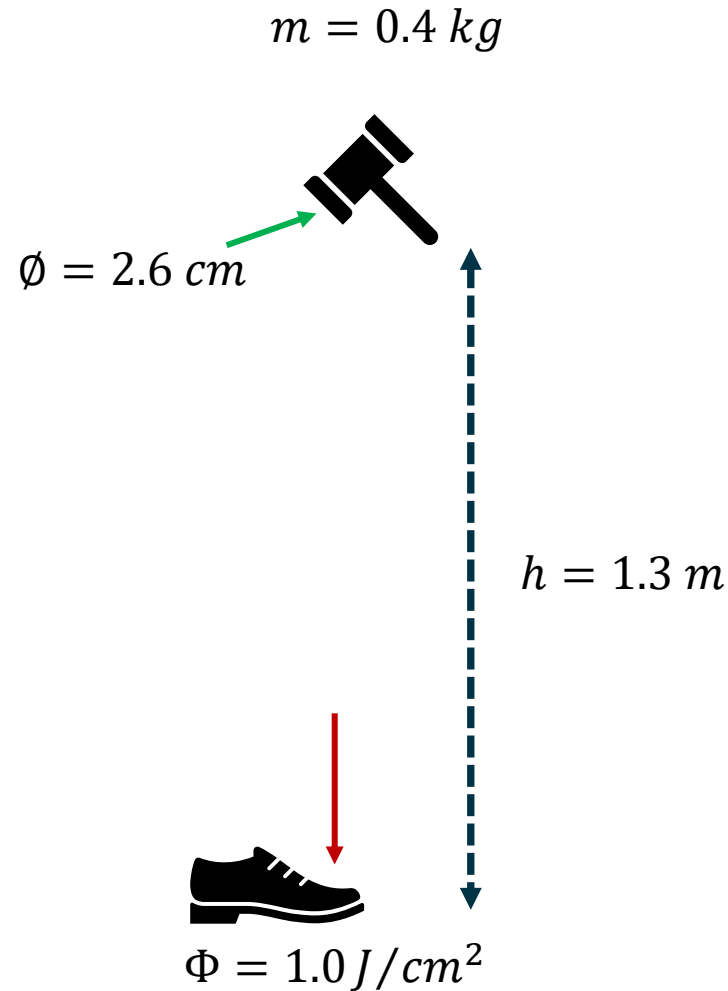

## Interaction time

- $\Delta t = 1 \text{ ms} \rightarrow I = 1 \text{ kW/cm}^2$
- $\Delta t = 1 \mu\text{s} \rightarrow I = 1 \text{ MW/cm}^2$
- ...
- $\Delta t = 1 \text{ ps} \rightarrow I = 1 \text{ TW/cm}^2$

Solar constant:  $137 \text{ mW/cm}^2$

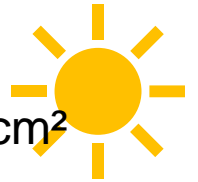

# Laser-induced Ablation Process

$$c_m = \frac{\Delta p}{E_L} = \frac{M_{target} V_{target}}{E_L} = \frac{m_{jet} \langle v_{jet} \rangle}{E_L}$$

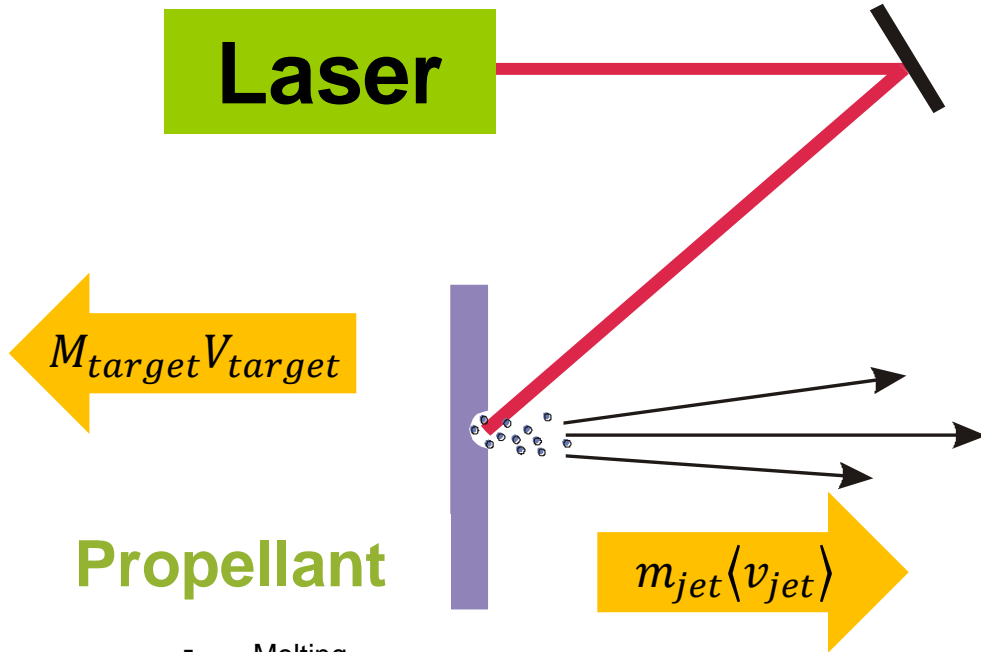

- Melting
- Vaporization
- Spallation (at ultra-short laser pulses)
- Plasma formation (at higher laser fluence)
- Thermal expansion
- Momentum transfer

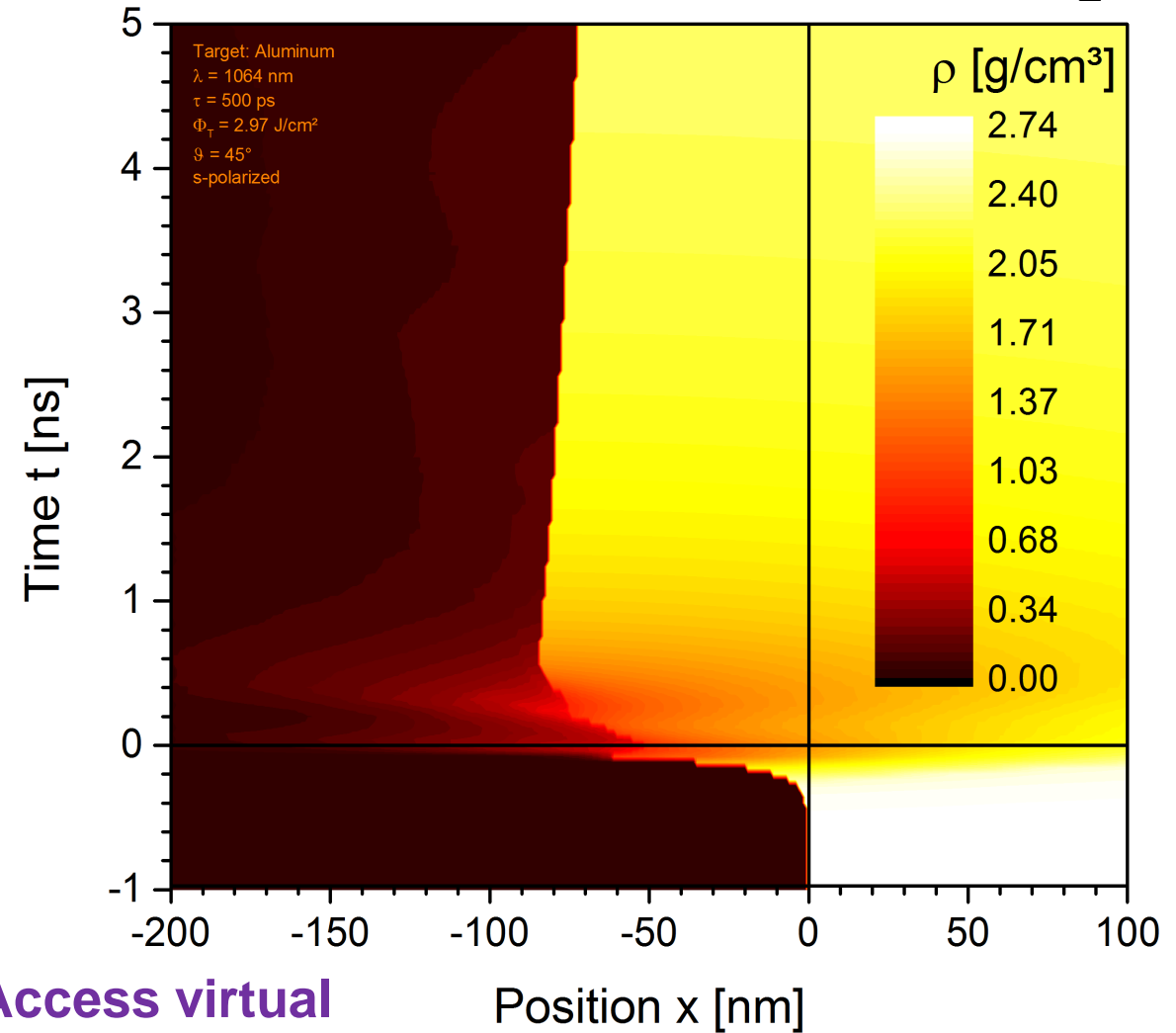

Access virtual  
laser lab



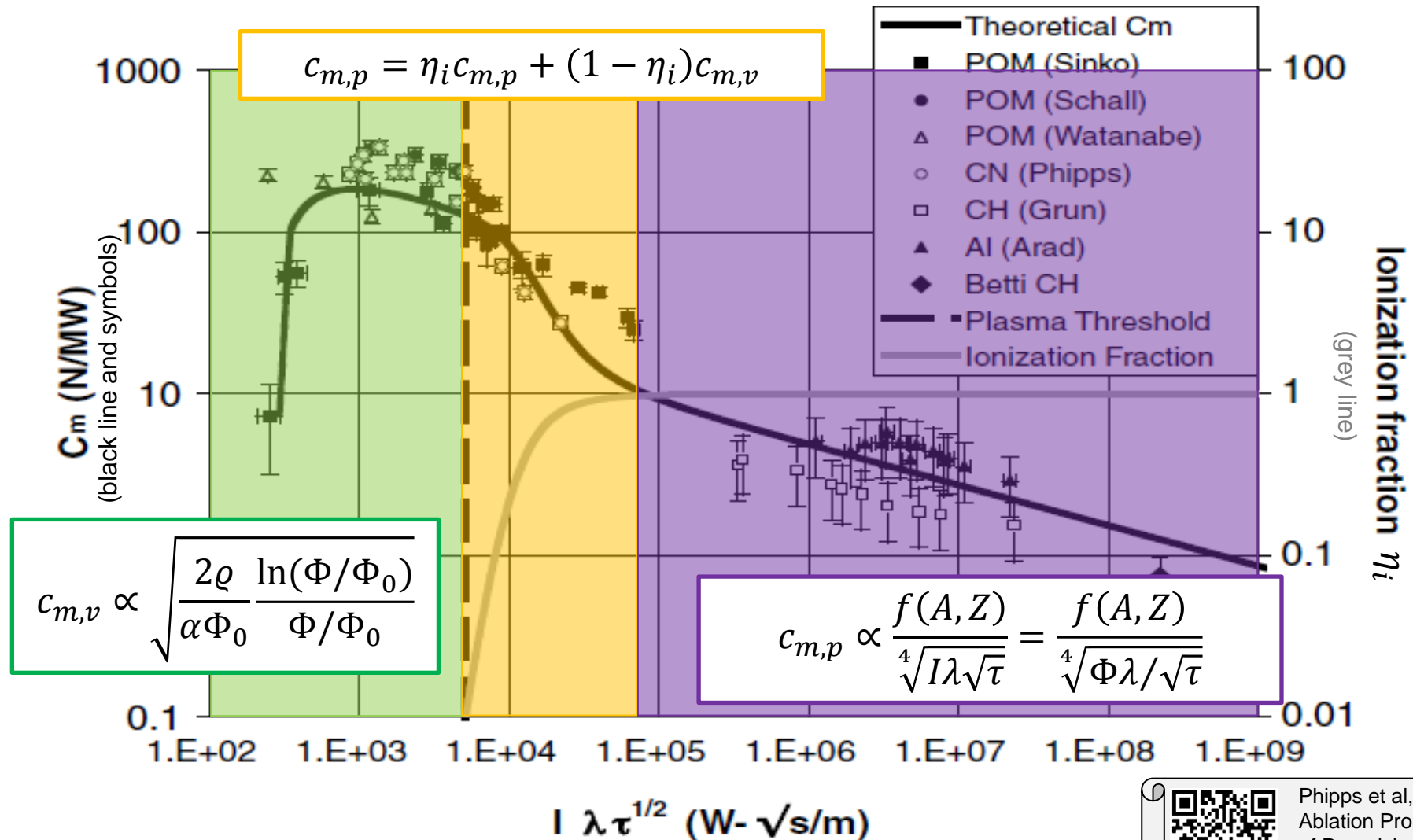

Results from hydrodynamic simulations with Polly-2T from the Joint Institute of High Temperatures, Russian Academy of Sciences, Moscow

# Regimes of Interaction in Laser Ablation

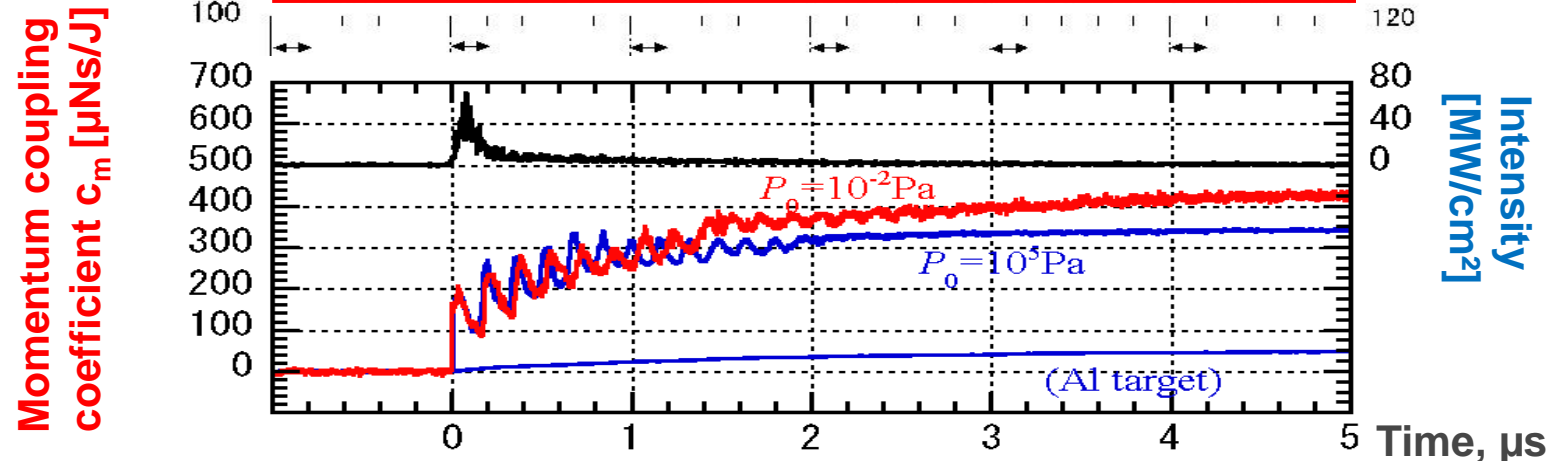
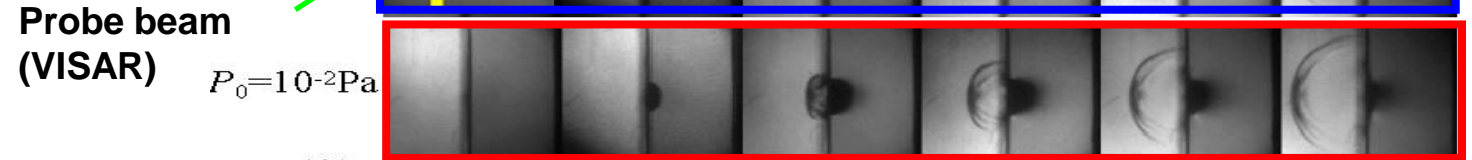
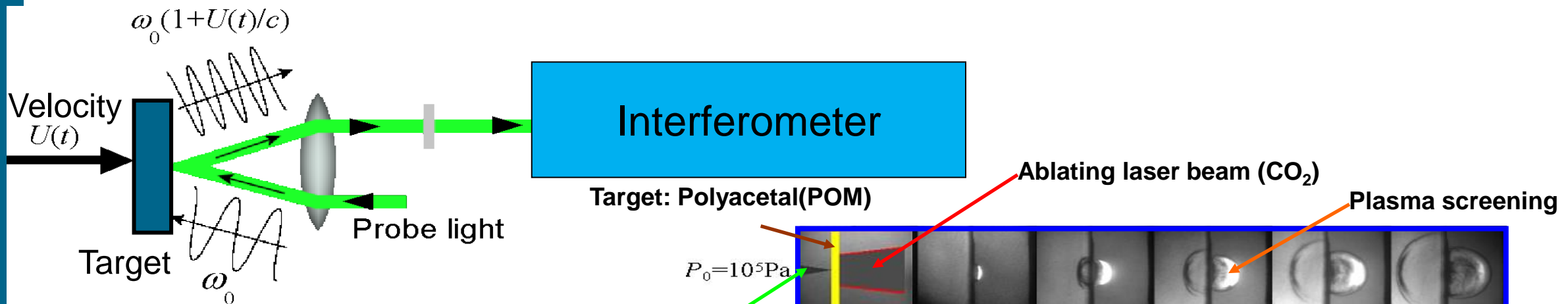

Phipps et al, Review: Laser-Ablation Propulsion, Journal of Propulsion and Power 26(4): 609-637 (2010), DOI: 10.2514/1.43733

# Measurement of momentum: Interferometry



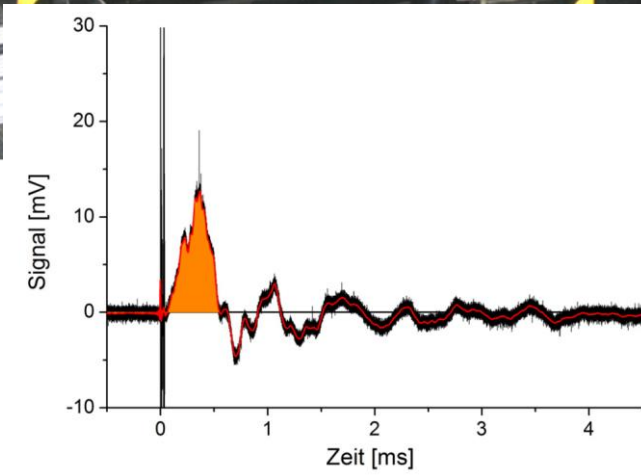
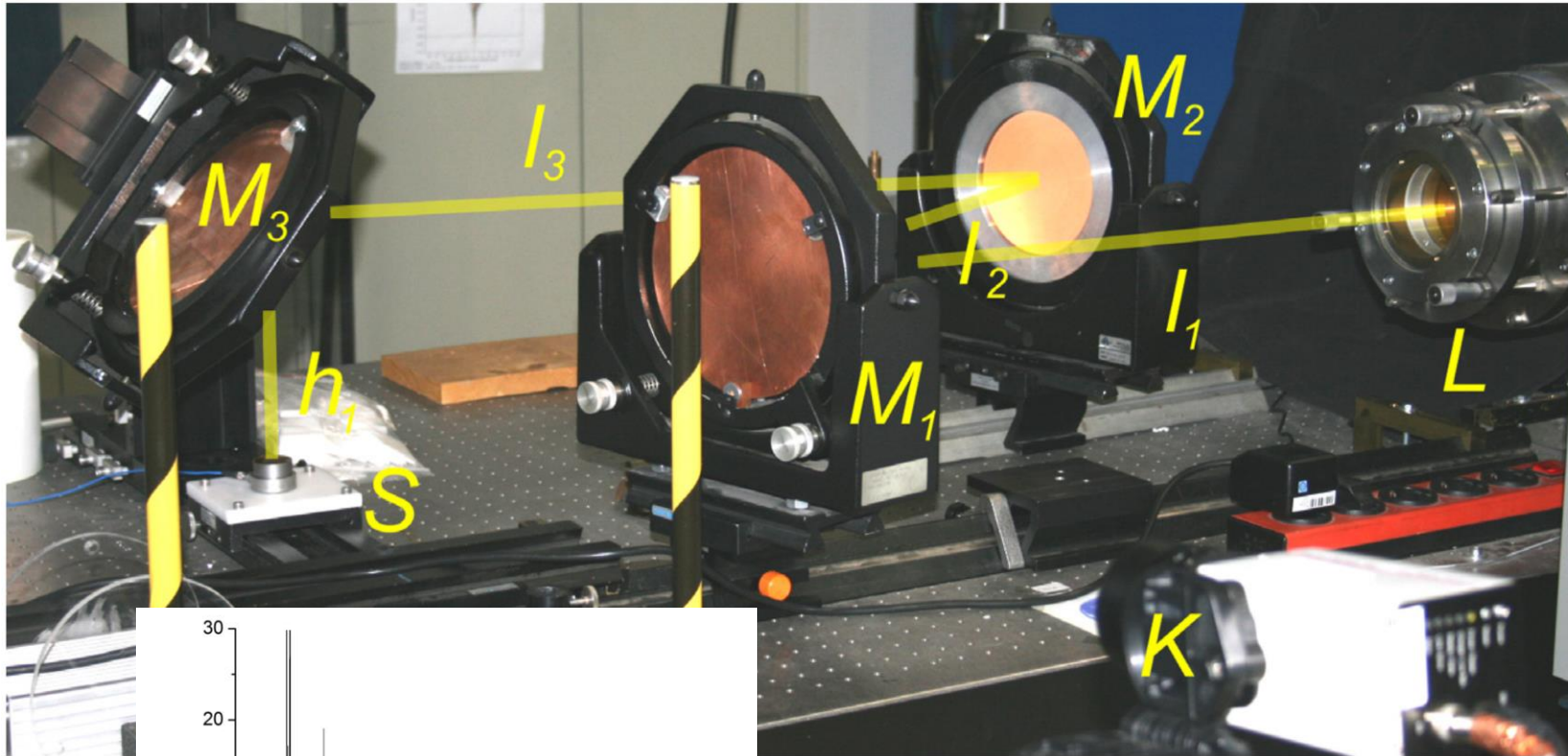

A. Sasoh et al, Diagnostics and Impulse Performance of Laser-Ablative Propulsion, AIP Conf. Proc. **997**: 232 (2008), DOI: 10.1063/1.2931894

# Measurement of momentum: Piezo-electric sensors

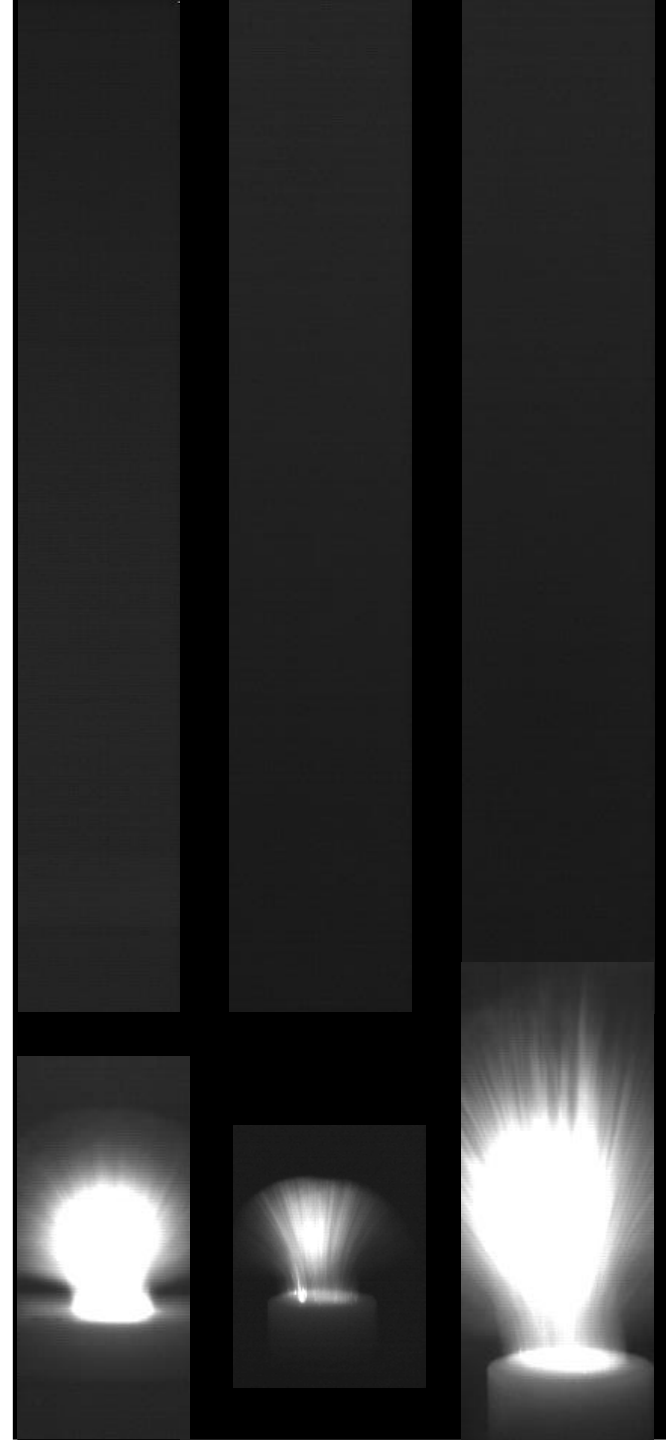

 S. Scharring, Impulse Analysis of Air-breathing Pulsed Laser-thermal Propulsion with a Parabolic Reflecting Nozzle for Space Applications, PhD thesis, University of Stuttgart (2012)



# Efficiencies in Laser Ablation

## Jet efficiency (Internal propulsion efficiency)

$$\eta_{jet} = \eta_{int} = \frac{\text{Reference jet kinetic energy}}{\text{Incident laser pulse energy}} = \frac{E_{jet,0}}{E_L}$$

$$= \frac{1/2 m_{jet} \langle v_{jet} \rangle^2}{E_L} = \frac{1}{2} c_m \langle v_{jet} \rangle = \frac{g}{2} c_m I_{sp} = \alpha \beta$$

Momentum conservation

$\beta$  Laser energy absorption efficiency  
 $\alpha$  Expansion efficiency

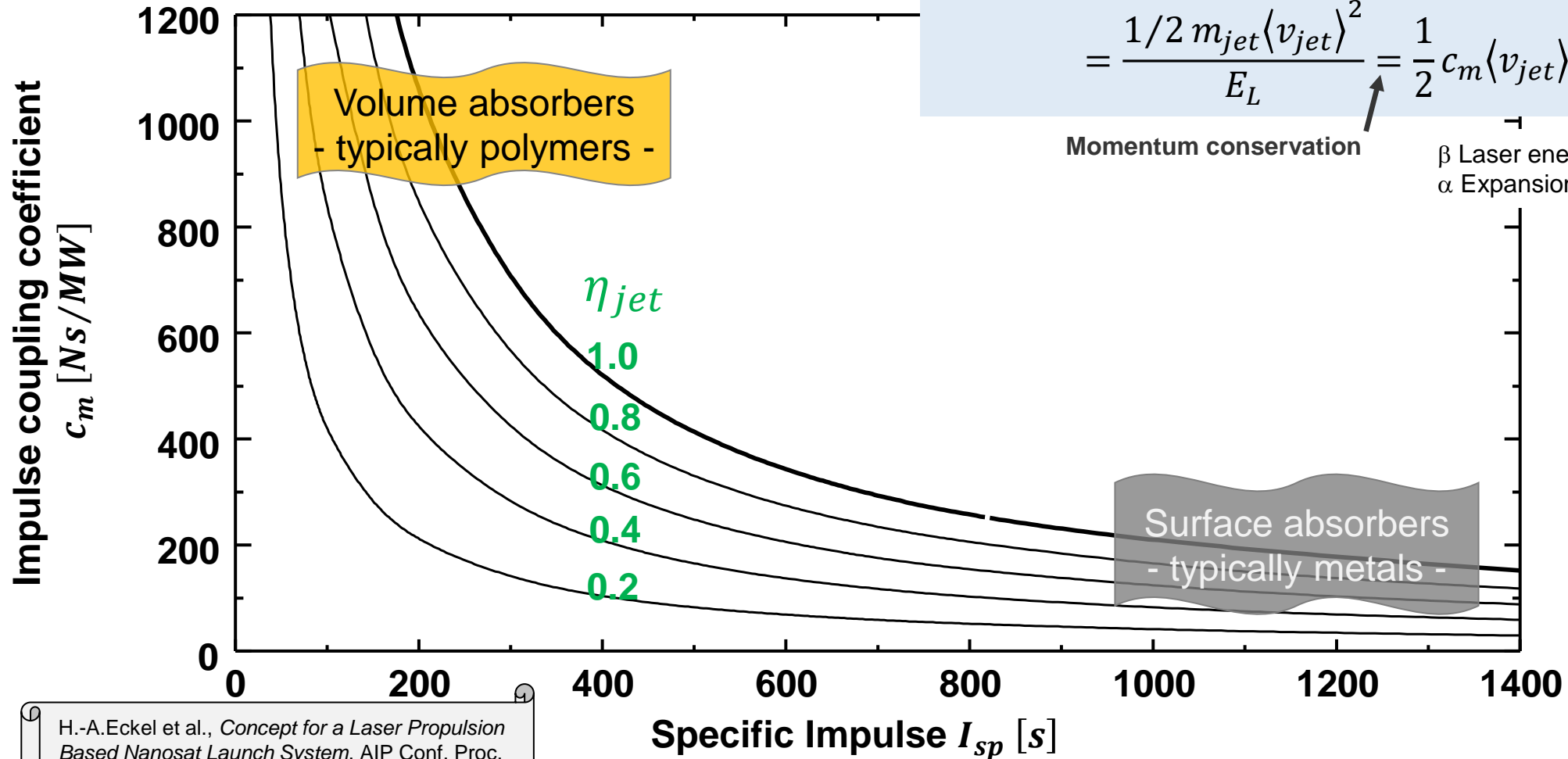

H.-A.Eckel et al., *Concept for a Laser Propulsion Based Nanosat Launch System*, AIP Conf. Proc. **702**, 263 – 273 (2004), DOI: 10.1063/1.1721006

# Efficiencies in Laser Ablation

### Jet efficiency (Internal propulsion efficiency)

$$\eta_{jet} = \eta_{int} = \frac{\text{Reference jet kinetic energy}}{\text{Incident laser pulse energy}} = \frac{E_{jet,0}}{E_L}$$

$$= \frac{1/2 m_{jet} \langle v_{jet} \rangle^2}{E_L} = \frac{1}{2} c_m \langle v_{jet} \rangle = \frac{g}{2} c_m I_{sp} = \alpha \beta$$

Momentum conservation  $\uparrow$   
 $\beta$  Laser energy absorption efficiency  
 $\alpha$  Expansion efficiency

### Jet monochromaticity

$$\psi = \frac{\text{Jet kinetic energy}}{\text{Reference jet kinetic energy}} = \frac{E_{jet}}{E_{jet,0}} = \frac{\sum_j [v_{jet,j}^2]}{\langle v_{jet} \rangle^2}$$

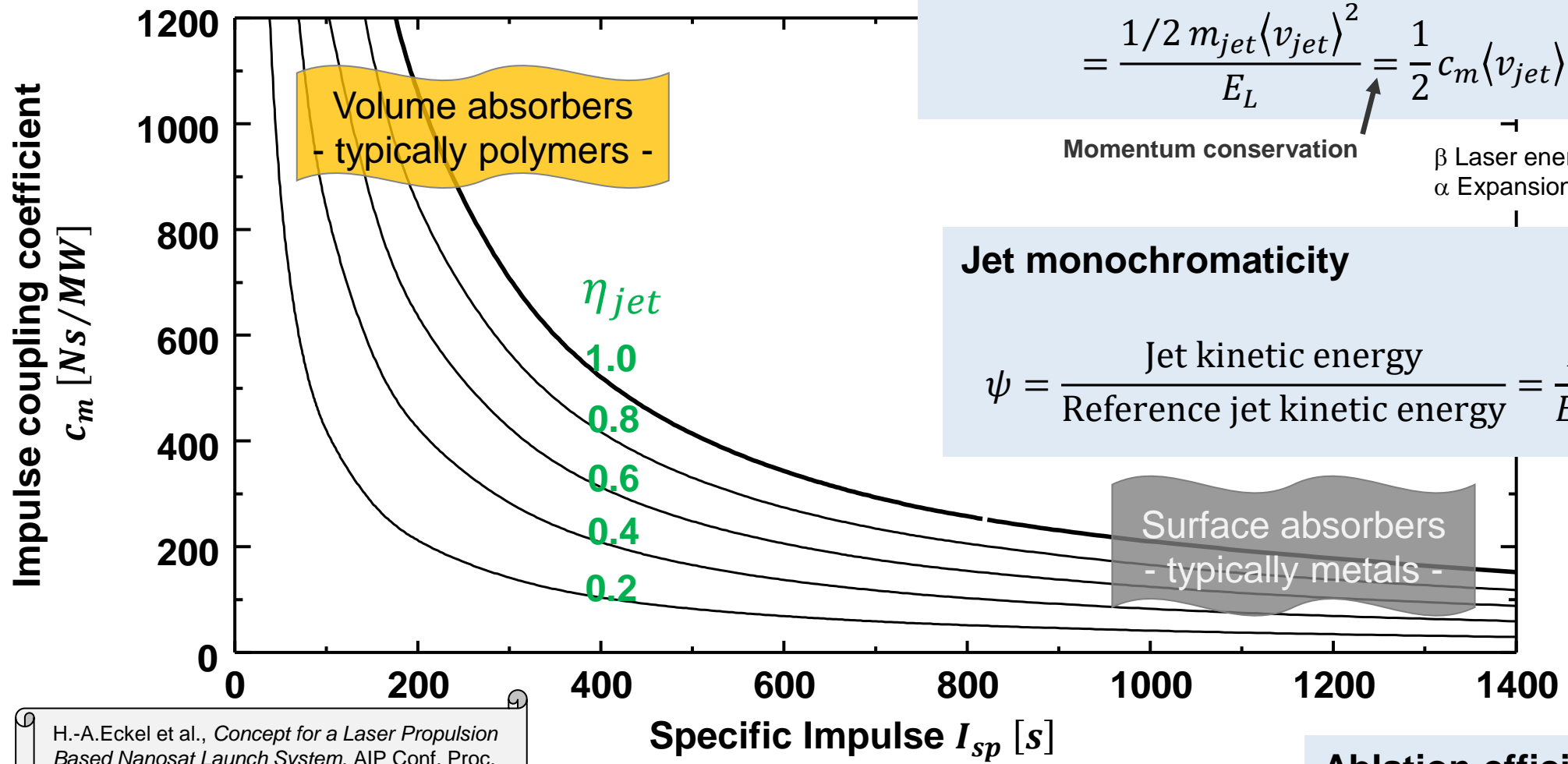

H.-A.Eckel et al., *Concept for a Laser Propulsion Based Nanosat Launch System*, AIP Conf. Proc. **702**, 263 – 273 (2004), DOI: 10.1063/1.1721006

### Ablation efficiency

$$\eta_{abl} = E_{jet}/E_L = \eta_{jet} \cdot \psi$$

# R-Mode Micro Laser Plasma Thruster (ns $\mu$ LPT)

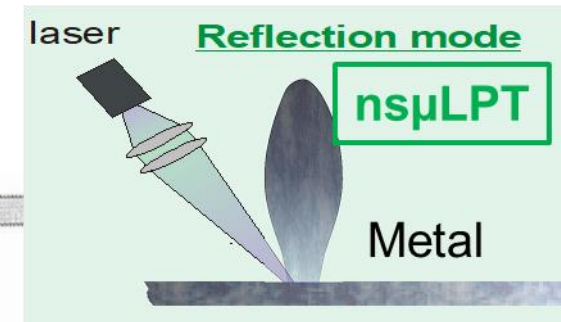

## Propellants:

Aluminium, Gold

$T$  0.47 ... 0.63  $\mu$ N (Au)  
0.94 ... 1.88  $\mu$ N (Al)

$c_m$  7.2 ... 68  $\mu$ N/W (Au)  
32 ... 111  $\mu$ N/W (Al)

$I_{sp}$  3664 ... 7905 s (Au)  
822 ... 6610 s (Al)

**Laser:** Nd:YAG-Laser

$\tau$  5 ns  
 $\lambda$  1064 nm  
 $f_{rep}$  10 Hz  
 $E_L$  1 ... 20 mJ

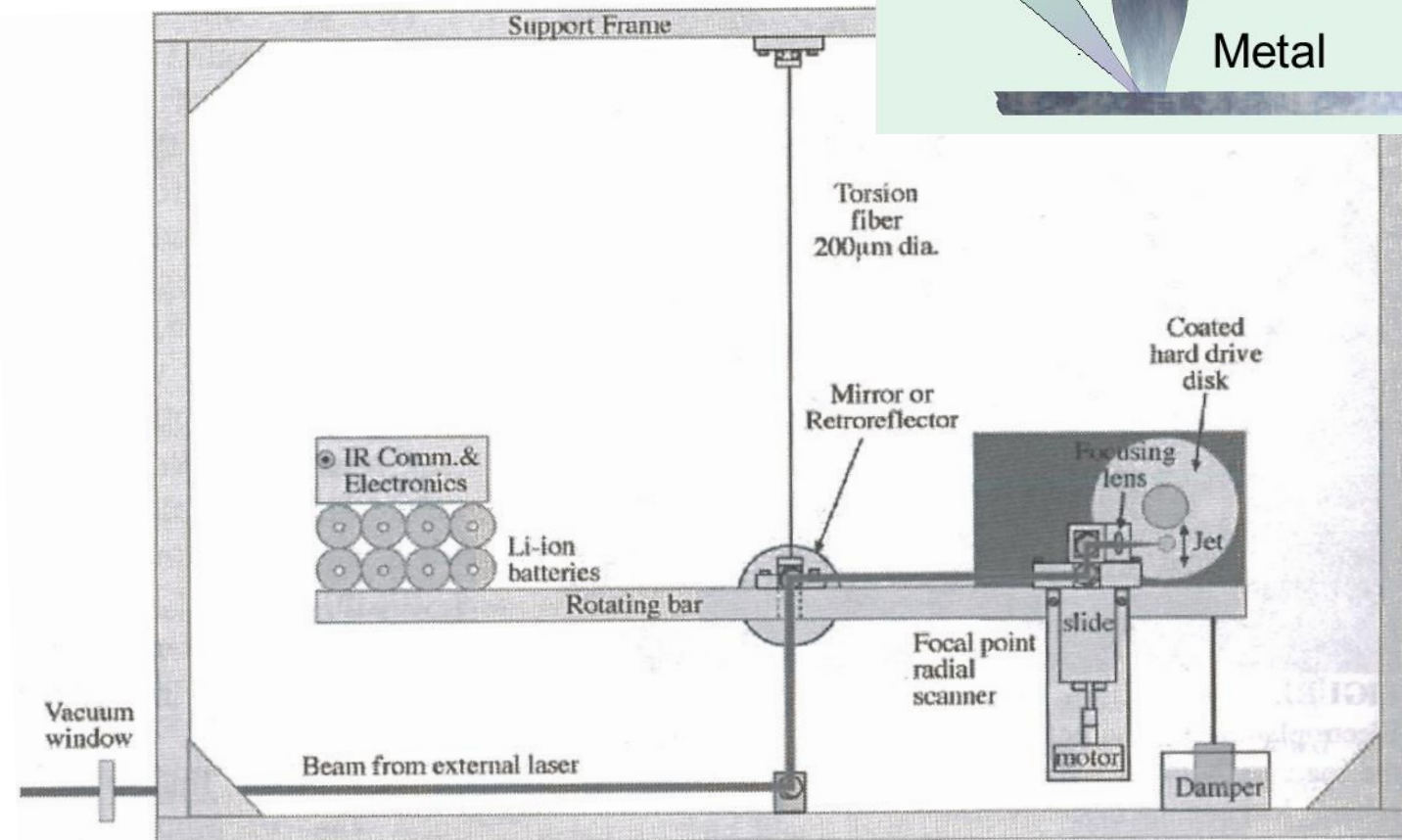

Minimum impulse bit:  $\Delta p = 0.04$  nNs

For comparison:  
FEPP  $\Delta p = 1$   $\mu$ Ns  
 $\mu$ PPT  $\Delta p = 2$   $\mu$ Ns

# T-Mode Micro Laser Plasma Thruster (ms $\mu$ LPT)

## Propellants:

PVC, exothermal polymer (C-doped)

$T$  0.14 ... 0.29 mN (PVC:C)  
2.8 ... 7.2 mN (EP:C I)

$c_m$  60 ... 120  $\mu$ N/W (PVC:C)  
1170 ... 3000  $\mu$ N/W (EP:C)

$I_{sp}$  650 ... 750 s (PVC:C)  
160 ... 540 s (EP:C)

**Laser:** Diode laser

$\tau$  2 ms

$\lambda$  920 nm

$f_{rep}$  80 Hz

$E_L$  30 mJ

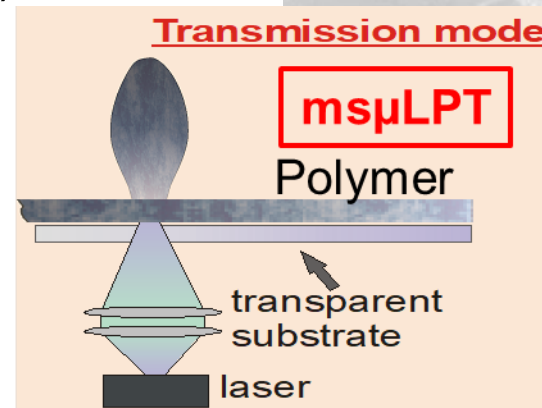

Minimum impulse bit:  $\Delta p = 0.05 \mu Ns$

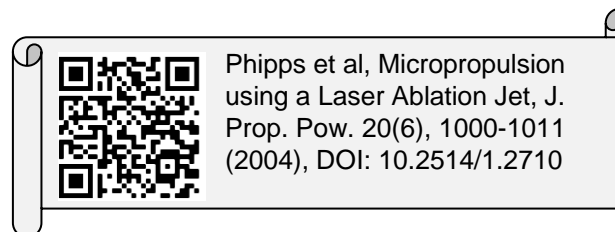

# Low-Noise Microthruster Concept (MICROLAS, DLR)

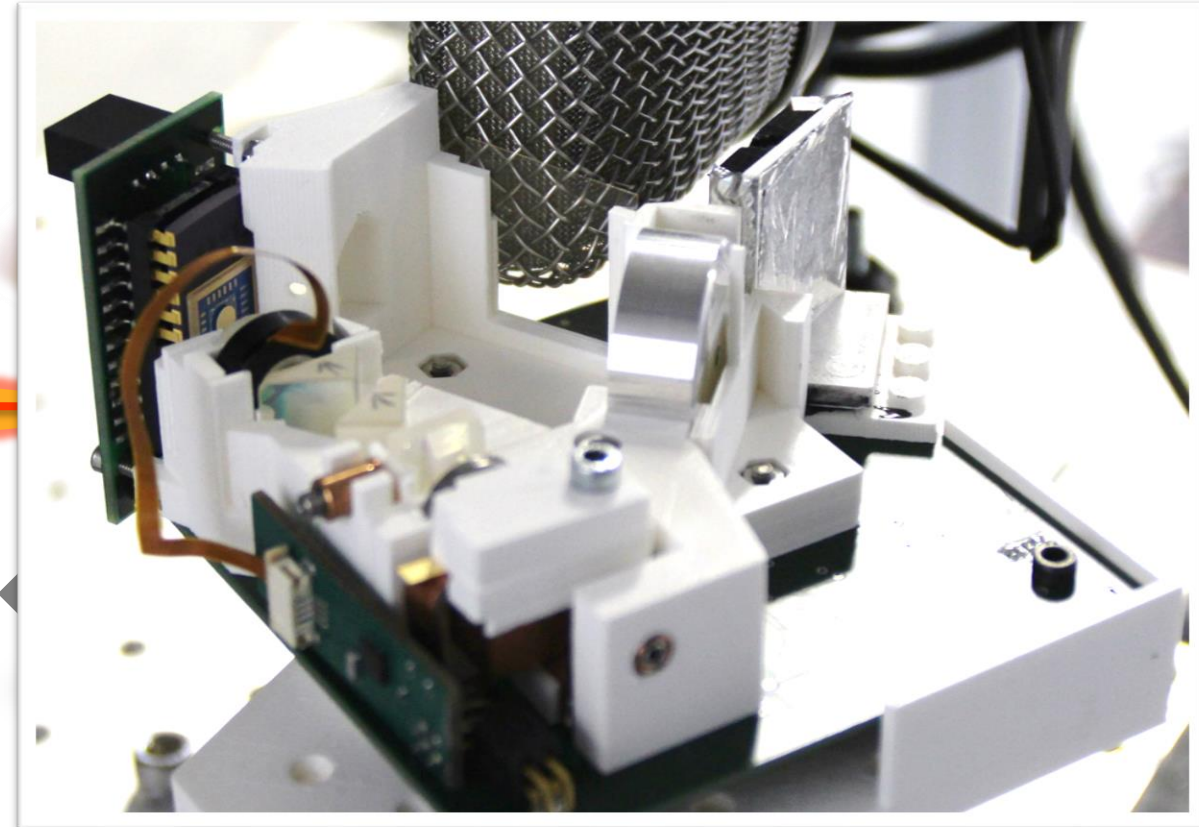
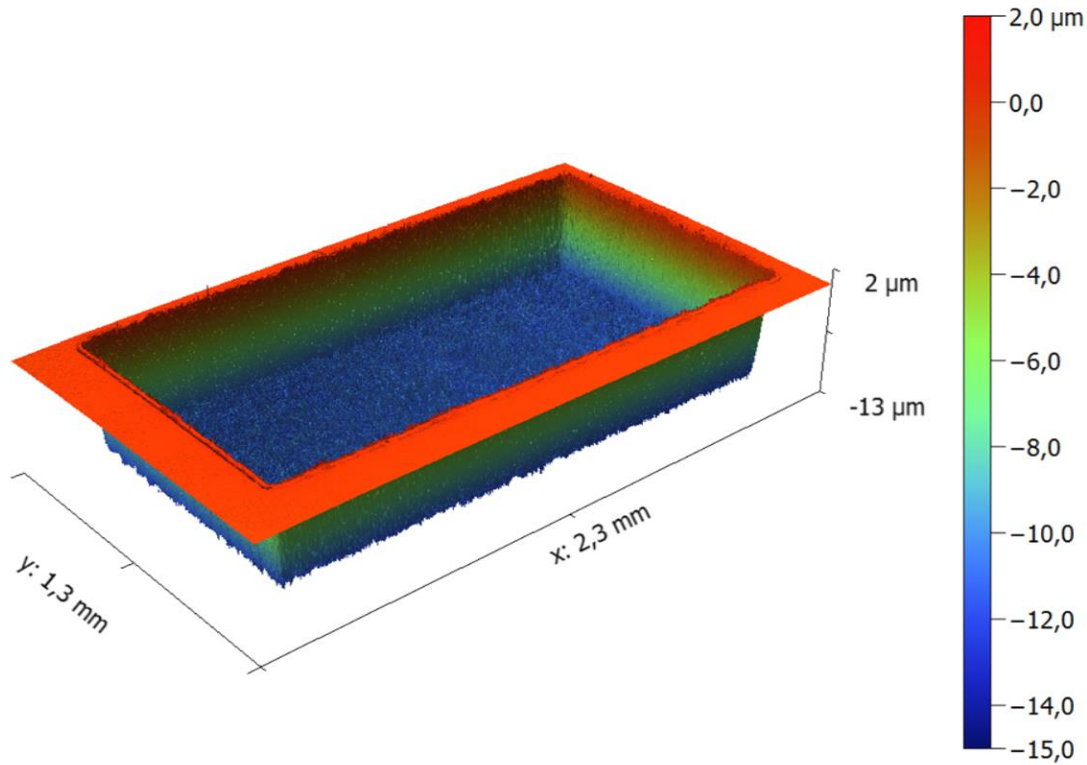

TU Dresden, 2016

**DLR microthruster demonstrator**

The background of the slide is a high-resolution photograph of a satellite in orbit above Earth. The satellite is the central focus, featuring a central body with various instruments and two long, rectangular solar panel arrays extending outwards. The Earth's surface below is a mix of green landmasses and blue oceans, with white clouds scattered across the scene. The curvature of the planet is visible at the top and bottom edges of the frame.

# VI. SPACECRAFTS' DEBRIS PROPULSION

# The Space Debris Threat



## Objects > 10 cm

- Fragments, Rocket bodies, Defective satellites
- s/c destruction (→ Kessler syndrome)
- Monitoring & obstacle avoidance possible
- 34,000 objects;
  - Public catalogue: 18,800 objects

## Objects between 1 cm and 10 cm

- s/c wall penetration (→ loss of functionality)
- Difficult to detect
- 900,000 objects (estimated)

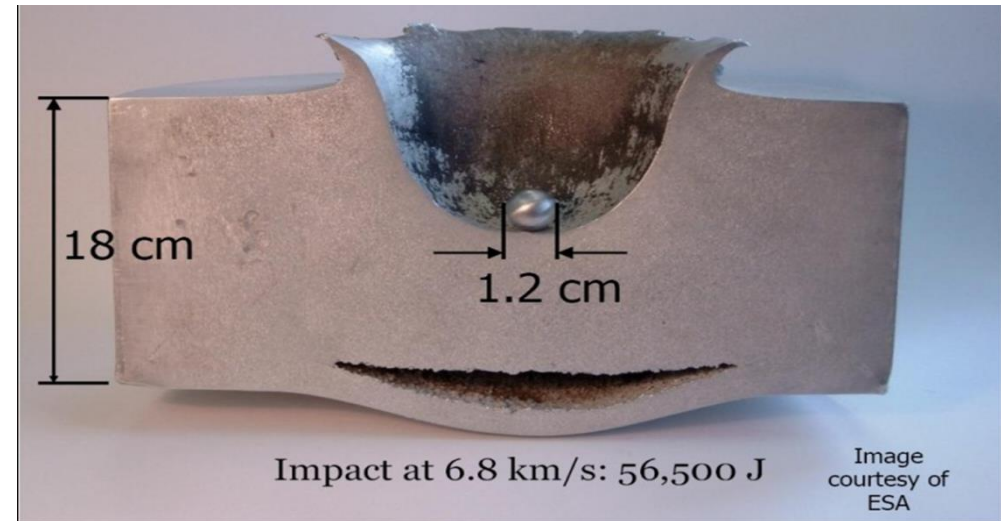

Impact of aluminum sphere in aluminum block @ 6.8 km/s

- 128,000,000 objects
- s/c damage (→ loss of performance)
- No detection possibilities

# In the Low Earth Orbit, everything is for a long time ...



Orbital residence time, **years:**

**1 25 100 1000**

2D spatial density distribution vs. altitude  
Cumulative contributions 2016-11-01, Objects > 1cm

...  
and  
there  
is  
less  
space  
than  
it  
may  
seem.

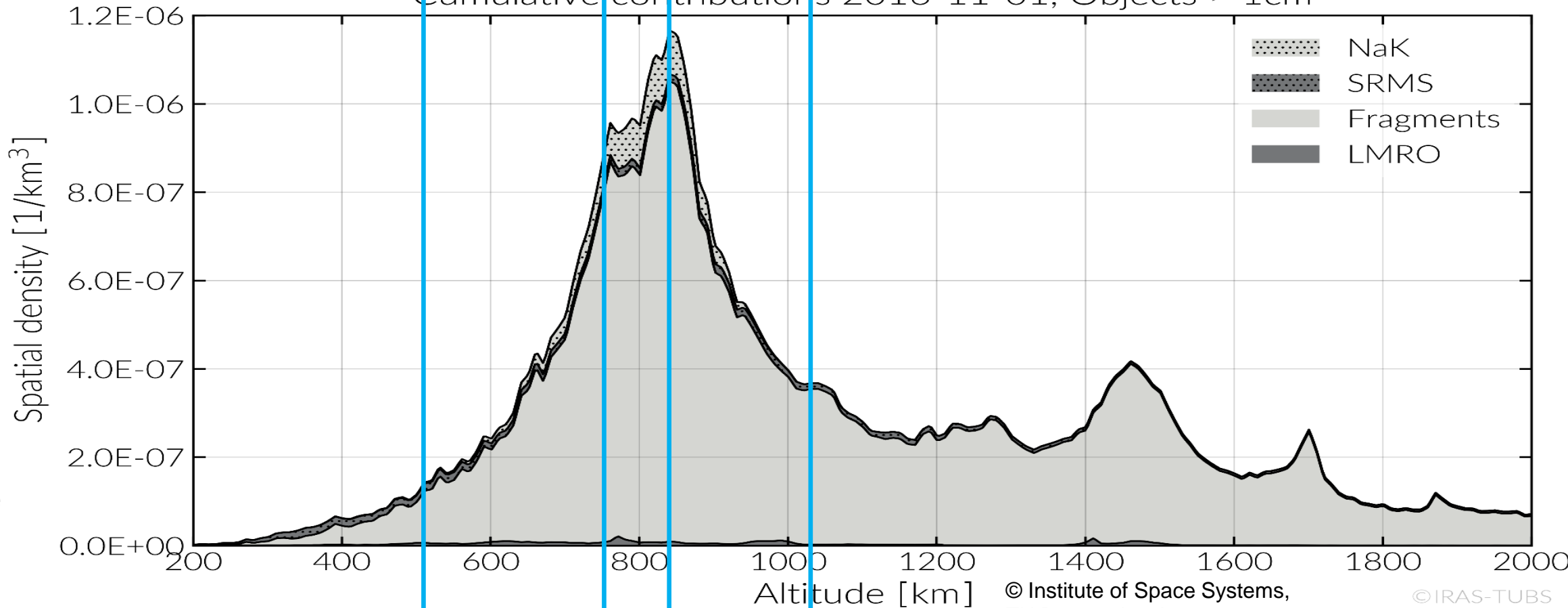

© Institute of Space Systems,  
TU Braunschweig

©IRAS-TUBS

... on high repeat ...

**Orbit period, minutes:** 94 99 101 106

94 99 101 106

# Debris Mitigation Step 1: Collision Avoidance

(Step 0: Avoid Generation of New Debris)

## Passive-optical Detection



## Laser Tracking

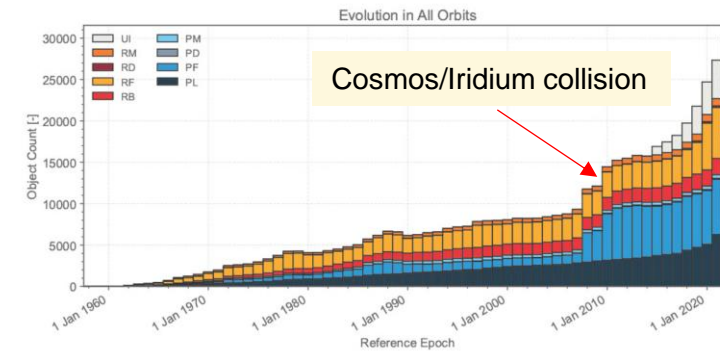
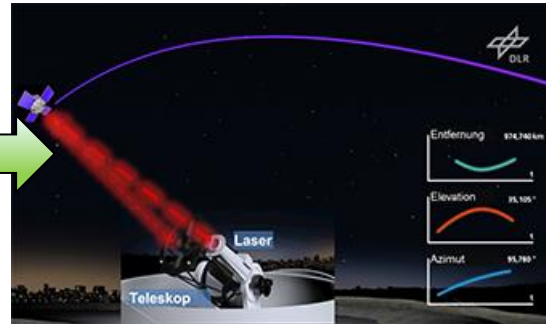

ESA's Annual Space Environment Report  
Issue Date 12 September 2023 Ref GEN-DB-LOG-00288-OPS-SD  
ESA Space Debris Office, European Space Operations Centre (ESOC), Darmstadt

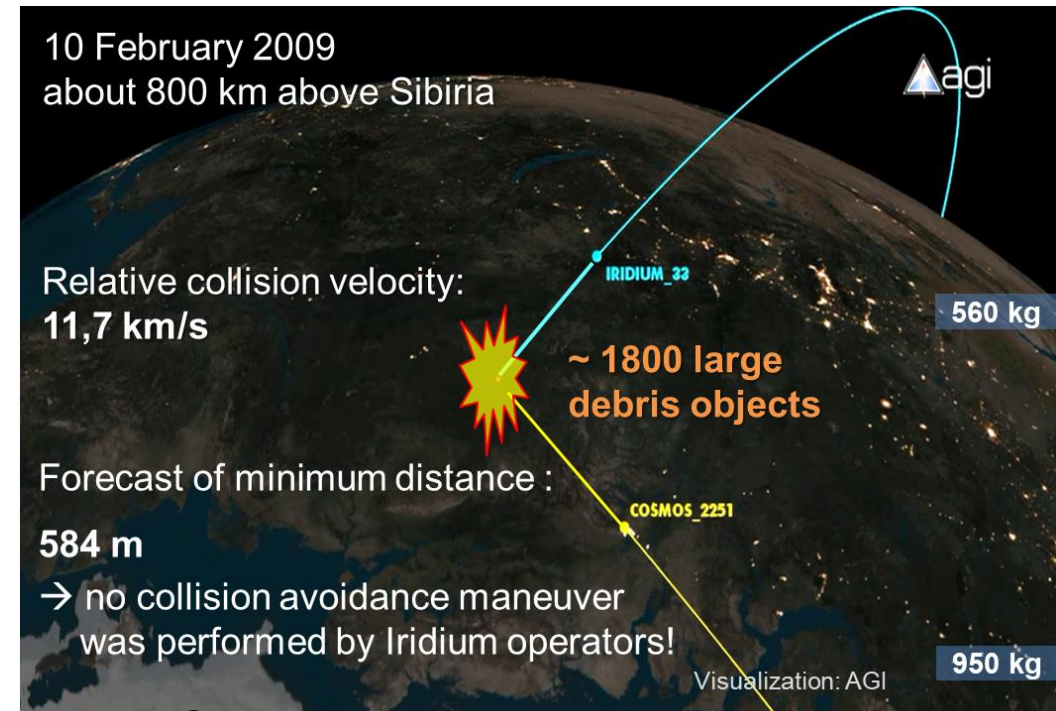

Yang et al., LightForce photon-pressure collision avoidance: Efficiency analysis in the current debris environment and long-term simulation perspective, *Acta Astronautica* **126**: 411 (2016), DOI: 10.1016/j.actaastro.2016.04.032

# Debris Mitigation Step 1: Collision Avoidance

(Step 0: Avoid Generation of New Debris)

## Passive-optical Detection



## Laser Tracking

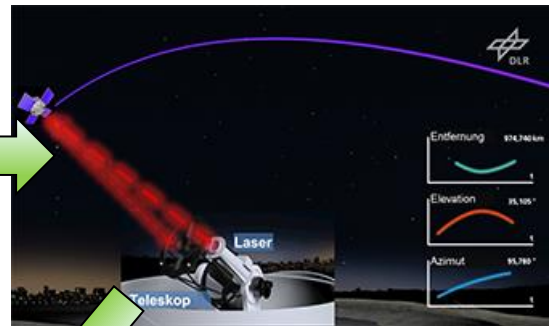

## Laser Debris Nudging

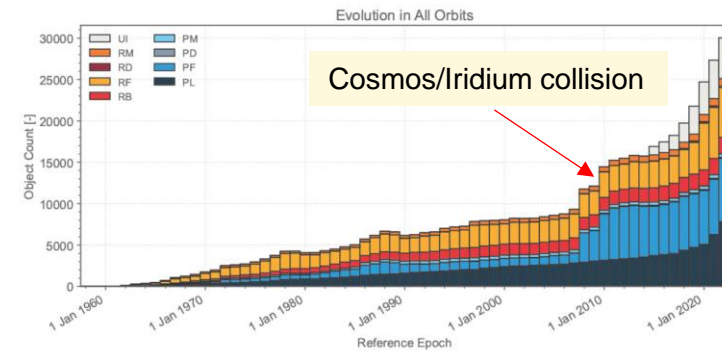
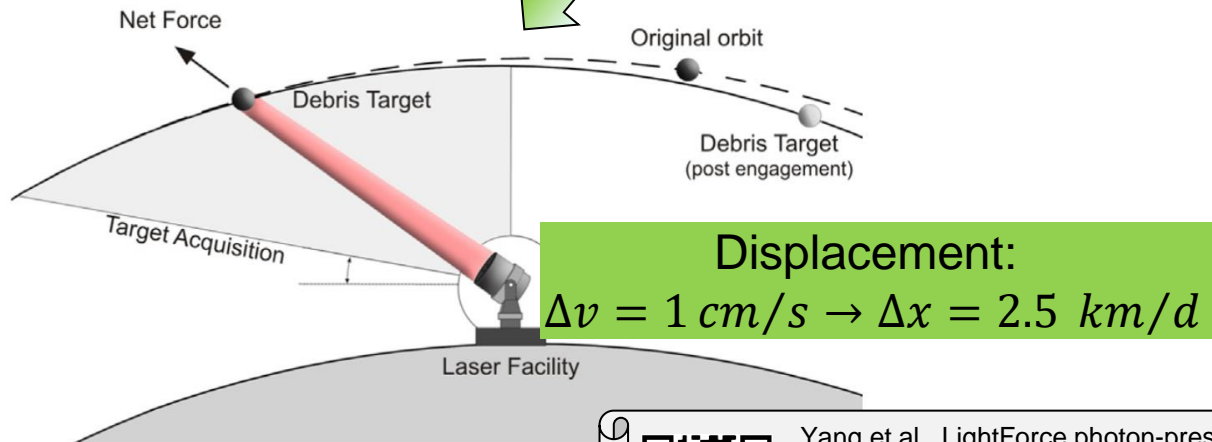

ESA's Annual Space Environment Report  
Issue Date 12 September 2023 Ref GEN-DB-LOG-00288-OPS-SD  
ESA Space Debris Office, European Space Operations Centre (ESOC), Darmstadt

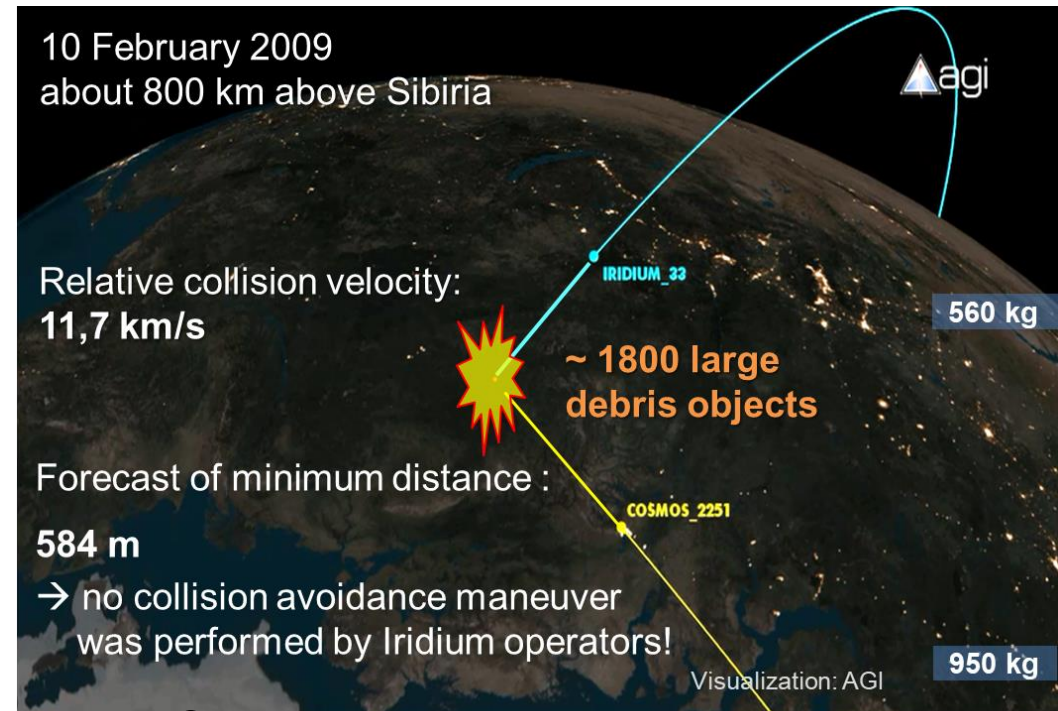

Yang et al., LightForce photon-pressure collision avoidance: Efficiency analysis in the current debris environment and long-term simulation perspective, *Acta Astronautica* **126**: 411 (2016), DOI: 10.1016/j.actaastro.2016.04.032

# Collision Avoidance by Laser Photon

## Laser Station Network

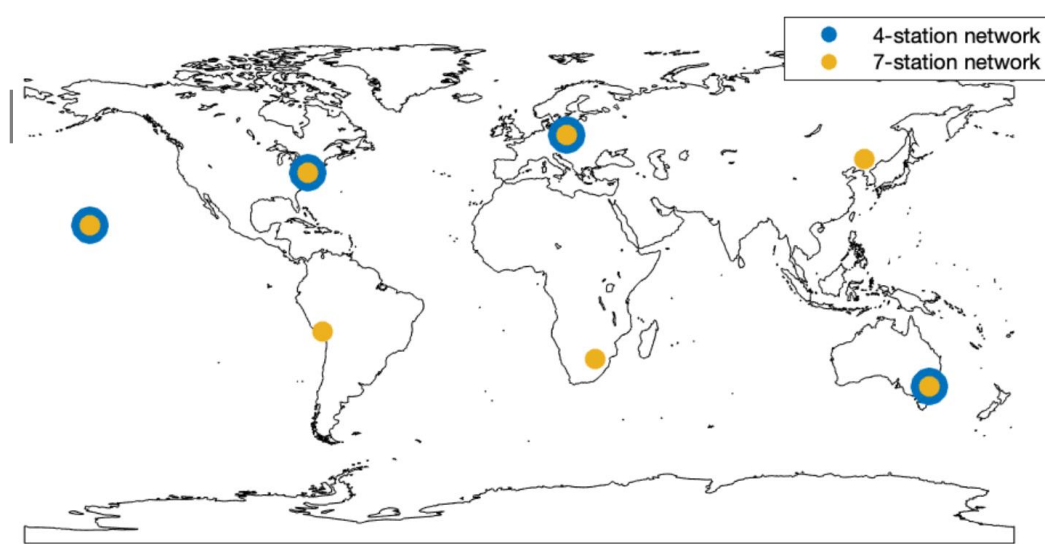

Single station transit  
 Irradiation time  $\Delta t = 5$  min,  
 Full power absorption  
 Momentum direction discarded

$$\rightarrow \Delta v = \frac{3.3 \mu\text{N/kW} \cdot P_L [\text{kW}] \cdot 300 \text{ s}}{m}$$

$$= 1 \text{ mm/s} \cdot \frac{P_L [\text{kW}]}{m [\text{kg}]}$$



C. Bamann et al., Analysis of collision avoidance via ground-based laser momentum transfer, *Journal of Space Safety Engineering* 7(3): 312-317 (2020). DOI: 10.1016/j.jsse.2020.07.023

Required MT success rate [%] for 80 % COLA success  
 Chaser altitude  $h = 850$  km, inclination  $i = 65^\circ$ , conjunction angle  $\psi = 45^\circ$   
 Only chaser nudged via MT

network	laser power [kW]	atmosphere	time to event [d]	$A/m = 0.008 \text{ m}^2/\text{kg}$	
				$S_T + S_C = 2 \text{ m}$	$S_T + S_C = 10 \text{ m}$
7-station network	40	none	6	1	4
			4	9	12
			2	34	45
	uncompensated	6	24	32	
		4	50	64	
		2	-	-	
4-station network	40	none	6	18	11
			4	19	24
			2	60	78
	uncompensated	6	43	53	
		4	83	-	
		2	-	-	

# Collision Avoidance by Laser Ablation

## Single pulse laser

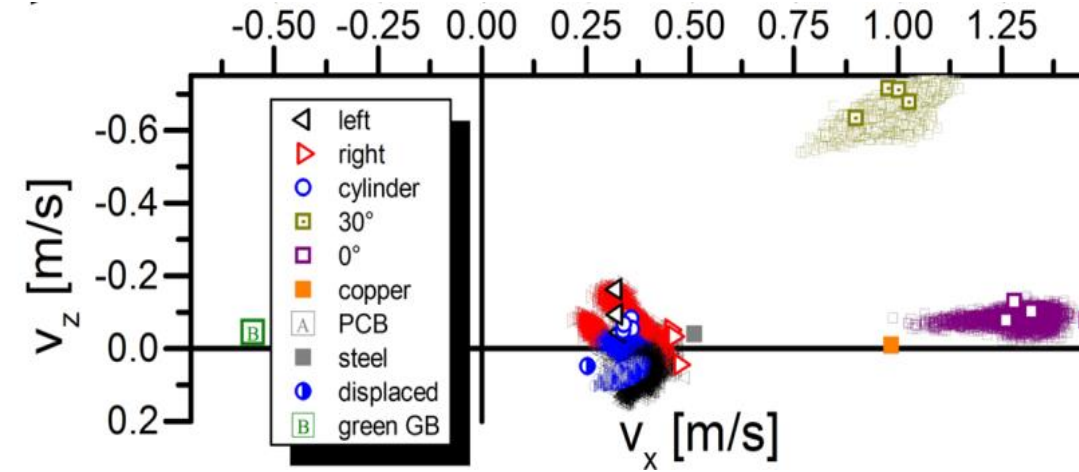
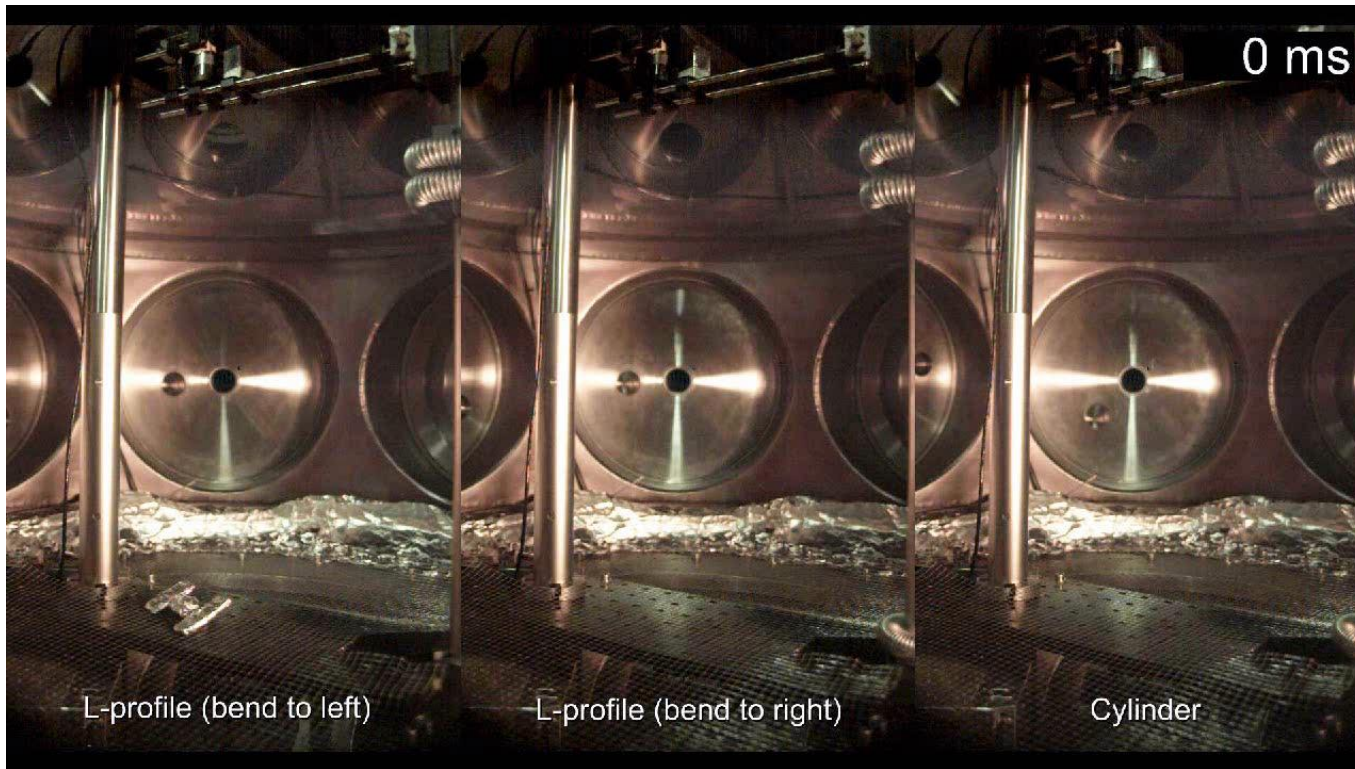
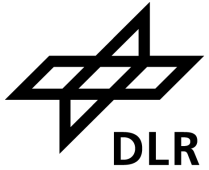

R. Lorbeer et al., Experimental verification of high energy laser-generated impulse for remote laser control of space debris, *Scientific Reports* **8**: 8453 (2018) (open access)  
DOI: 10.1038/s41598-018-26336-1

# Astrodynamical Options for Space Debris Orbit Modification

Target deceleration for atmospheric burn-up

## Perigee lowering

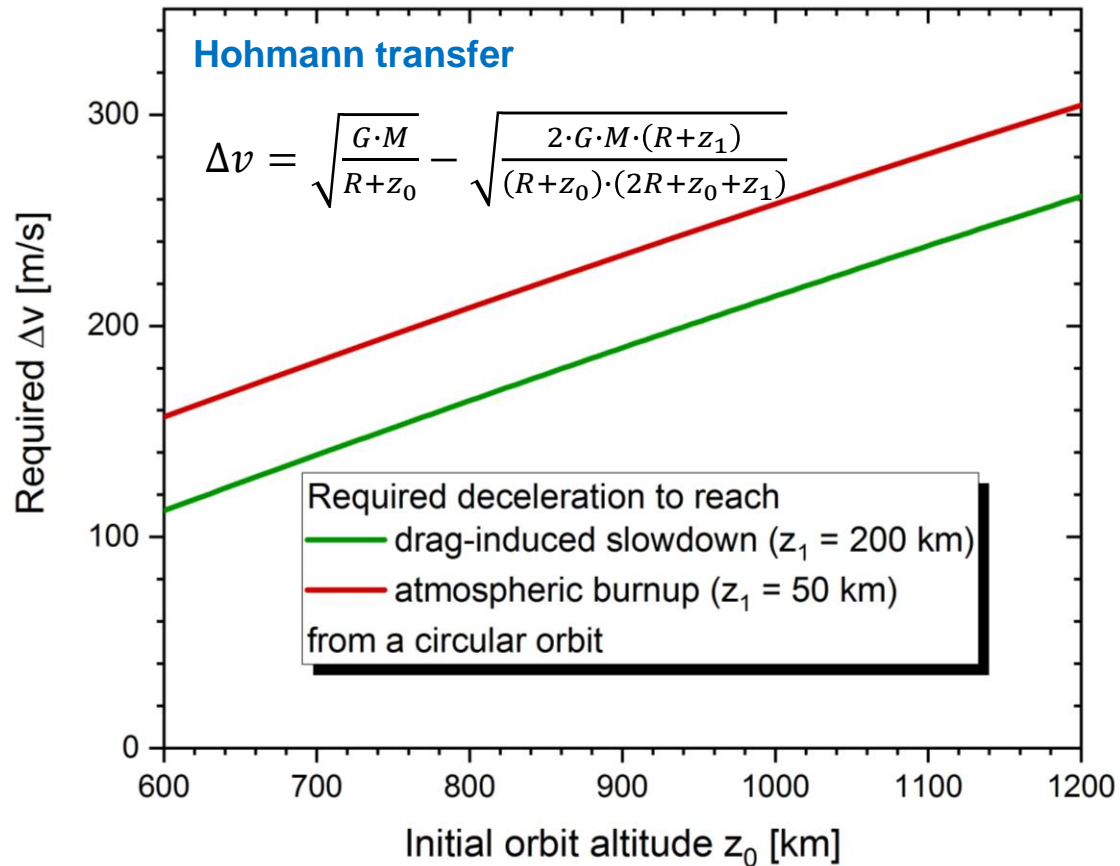

In-track / radial momentum transfer

## Apogee lift + perigee lowering

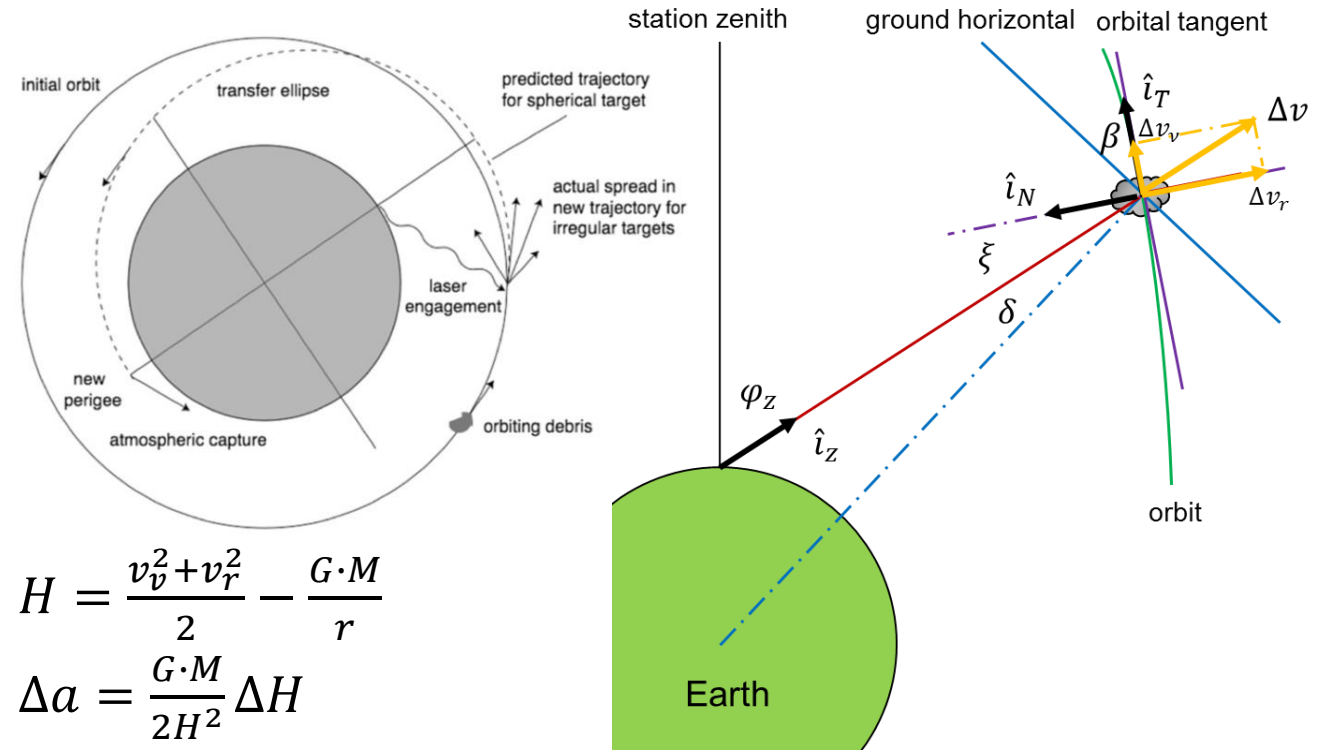

$$H = \frac{v_v^2 + v_r^2}{2} - \frac{G \cdot M}{r}$$

$$\Delta a = \frac{G \cdot M}{2H^2} \Delta H$$

$$\Delta r_p = (1 - \epsilon) \Delta a - a \Delta \epsilon$$

$$\Delta r_a = (1 + \epsilon) \Delta a + a \Delta \epsilon$$

adapted from:



C.R. Phipps et al., Removing orbital debris with lasers, *Advances in Space Research* **49**: 1283 (2012)  
doi:10.1016/j.asr.2012.02.003

# Summary

- $F_{S/c} = \dot{p}_{S/c} = -\dot{p}_t = -F_t$

- Laser propulsion is electric propulsion

- Lasers: Pump source, gain media, resonator, output coupler.

- $c_m = \frac{F}{P_L} = \frac{\Delta p}{E_L}$

- Ablativ:

- MW Laser -> N
    - kW Laser -> mN
    - W Laser ->  $\mu$ N

- Photonen:

- ca. 10000 kleiner.

- $R = c_{opt} \sqrt{Str} \frac{D \cdot d}{\lambda}$

- $D = 5 \text{ m}, d = 1 \text{ m}, \lambda = 1 \mu\text{m} \rightarrow R \approx 1000 \text{ km}$

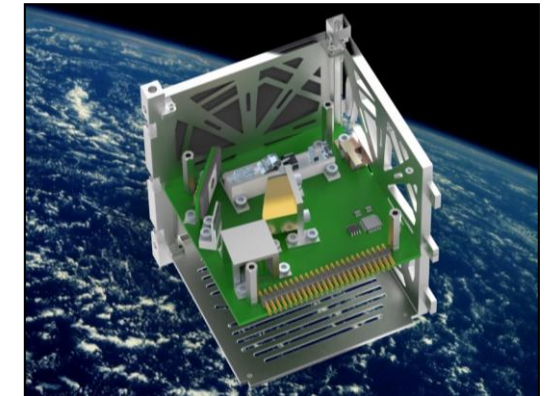
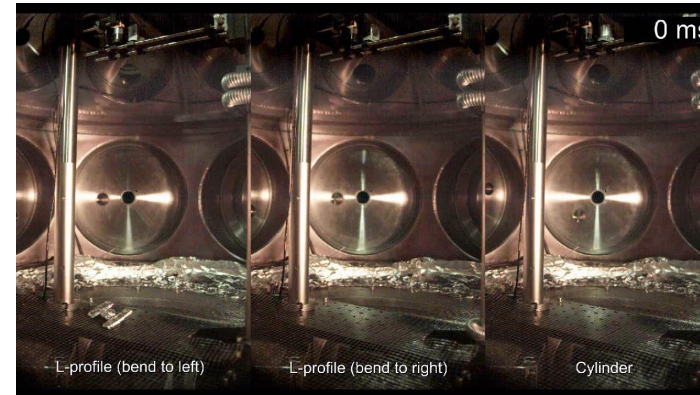
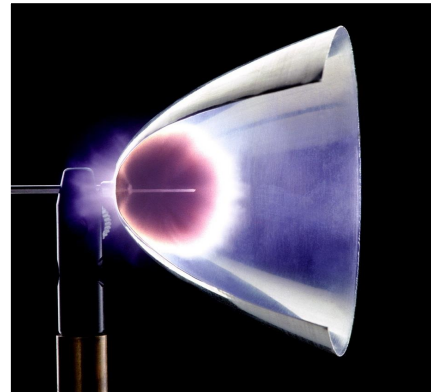

# THANK YOU FOR YOUR KIND ATTENTION

Dr. Raoul-Amadeus Lorbeer, DLR Institute of Technical Physics

Lasers and Space

*Watch this lecture and more at:*

