

EXACT2:SHORT-, MID-, AND LONG RANGE AIRCRAFT CONFIGURATION OVERVIEW

Felix Fritzsche, Msc.
DLR-SL
01.10.2024

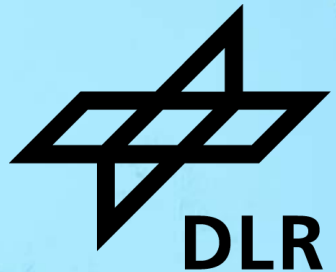

EXACT 2 Project Structure

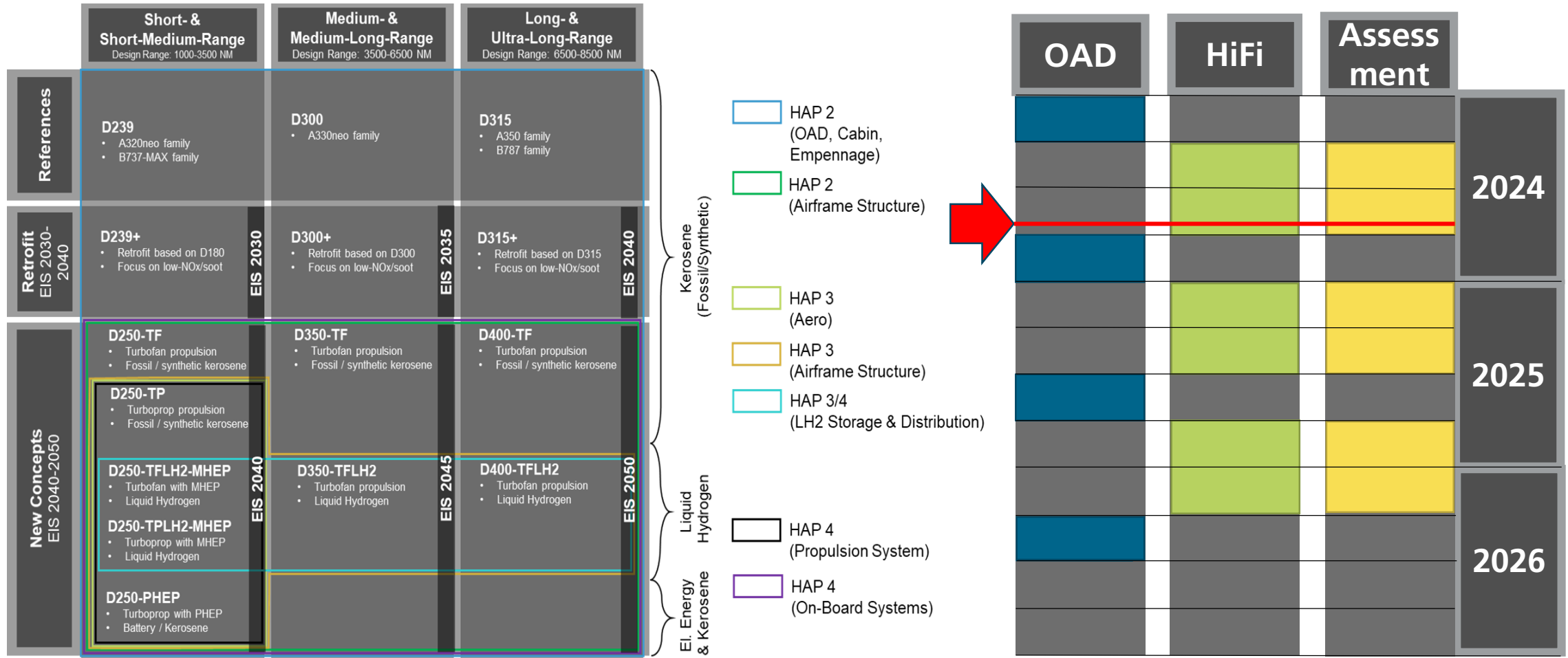



OAD WORKFLOW



OAD Workflow Overview

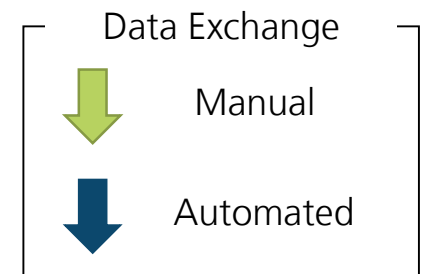
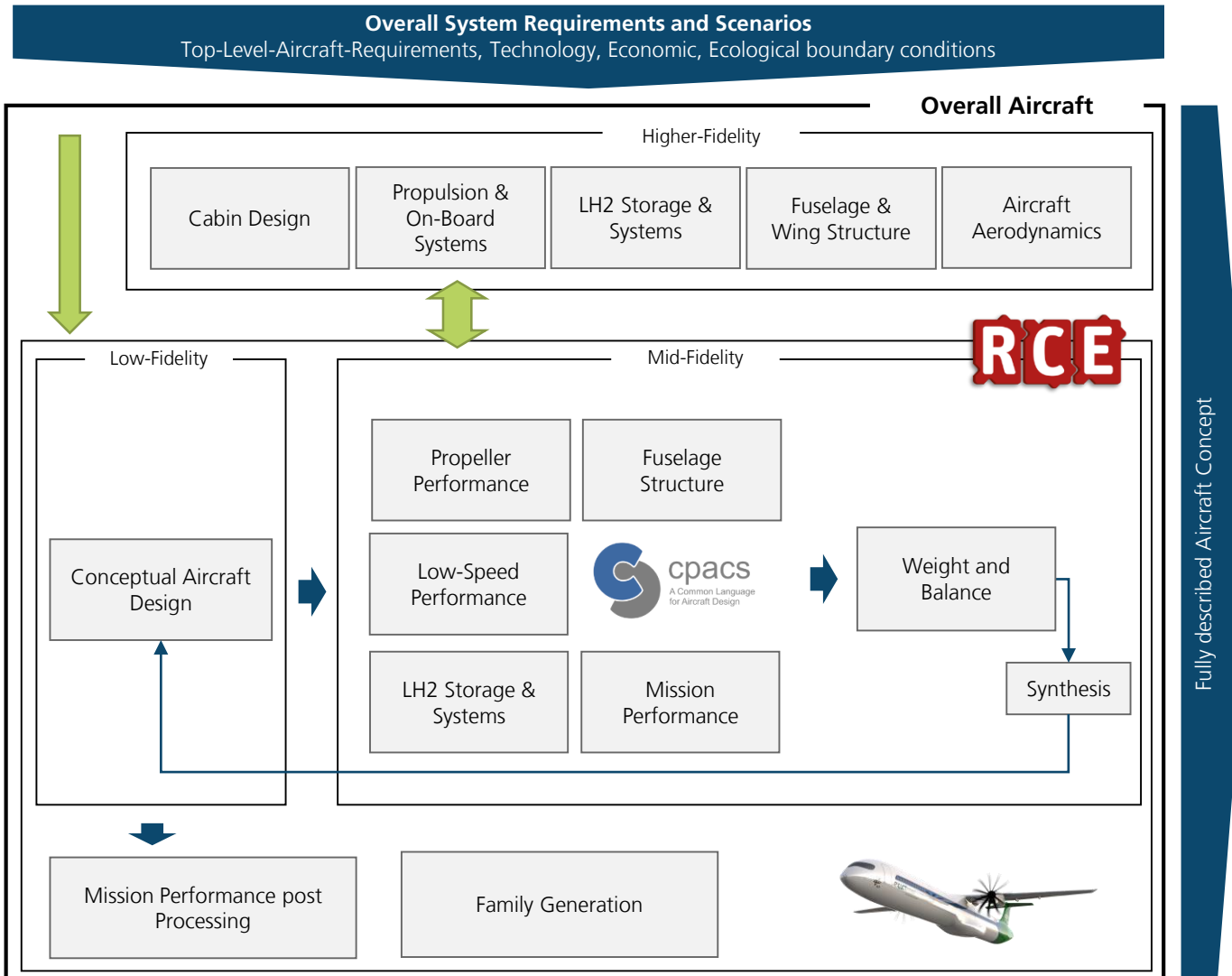

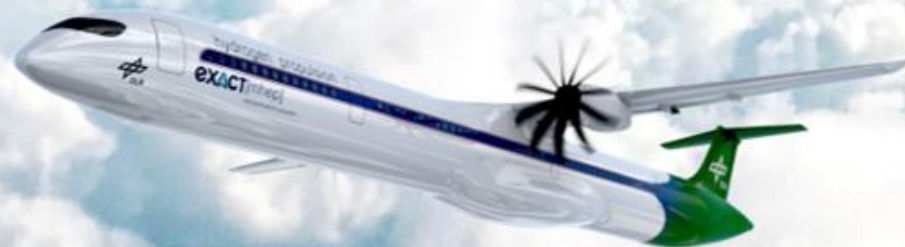
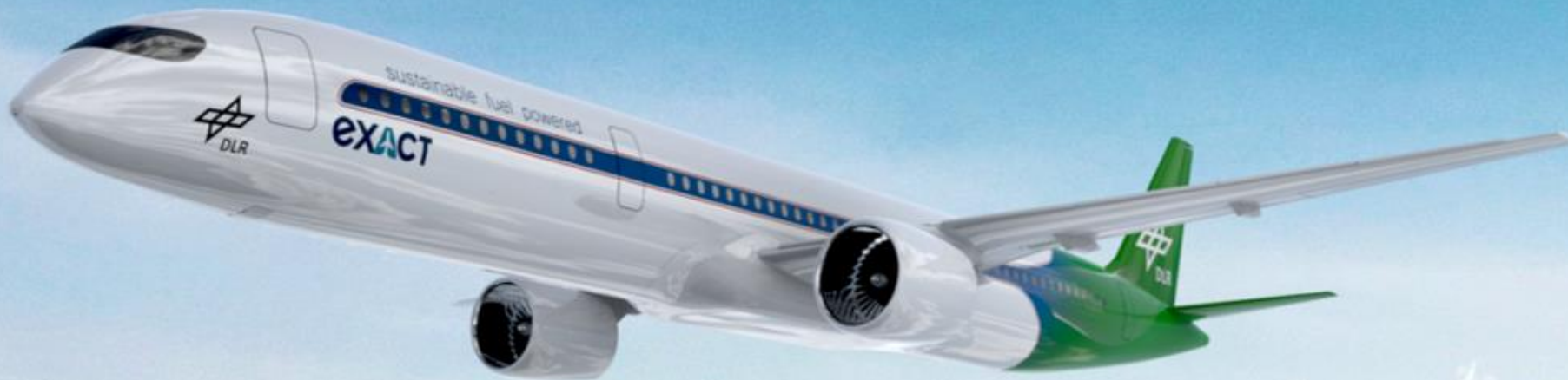

AIRCRAFT CONCEPTS

Aircraft Concepts Overview

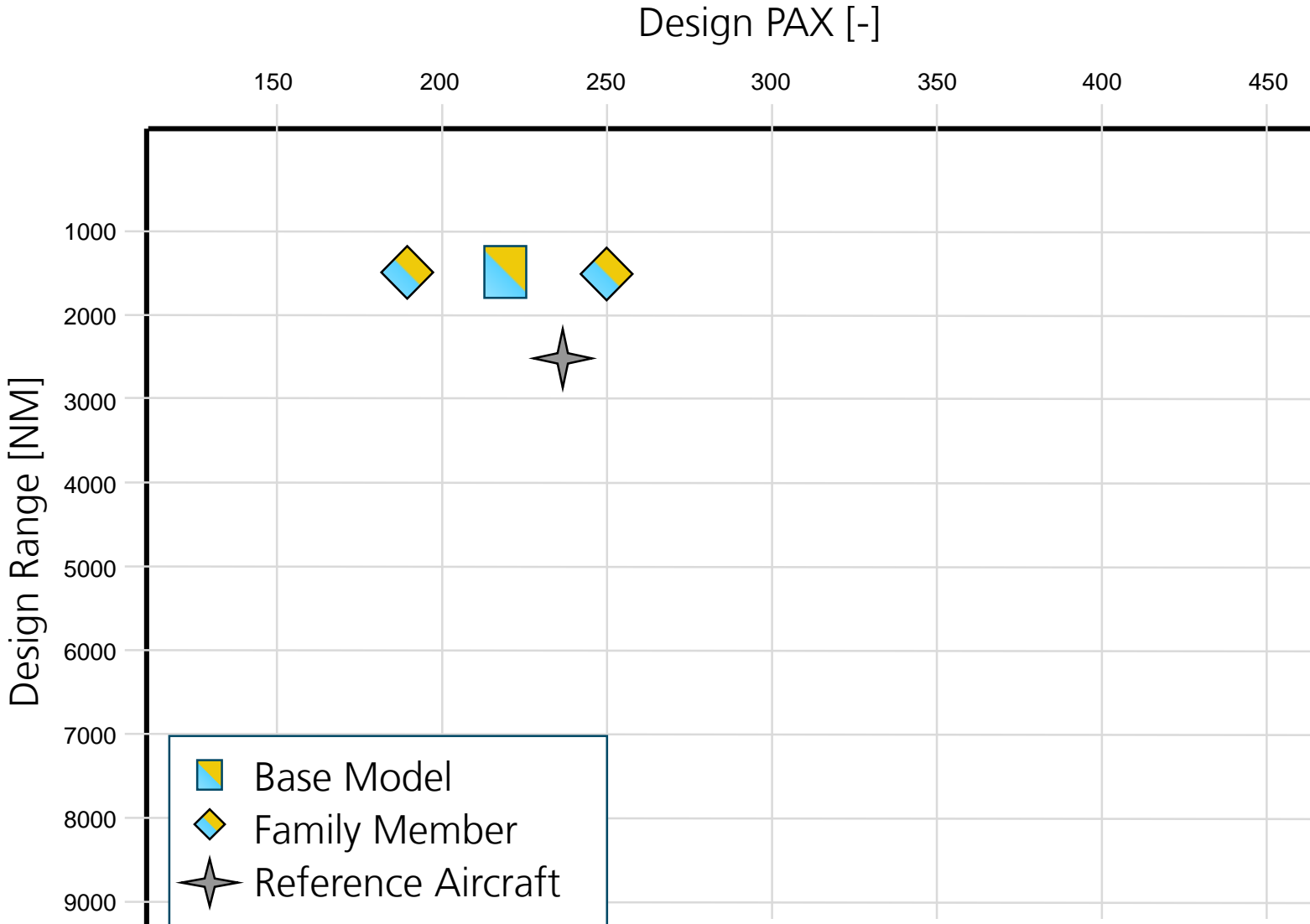

Aircraft Concepts Overview

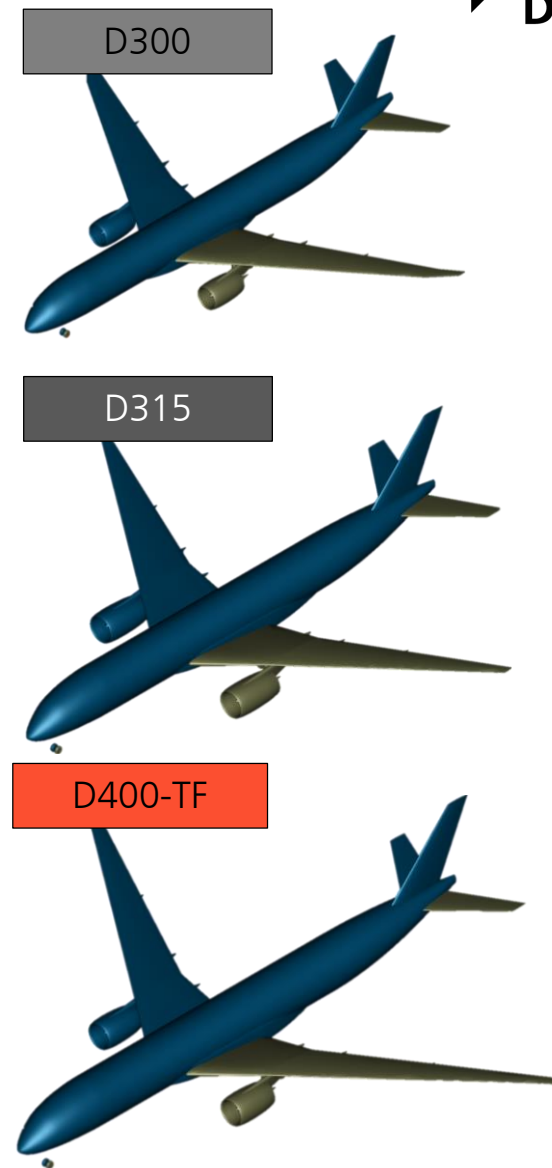
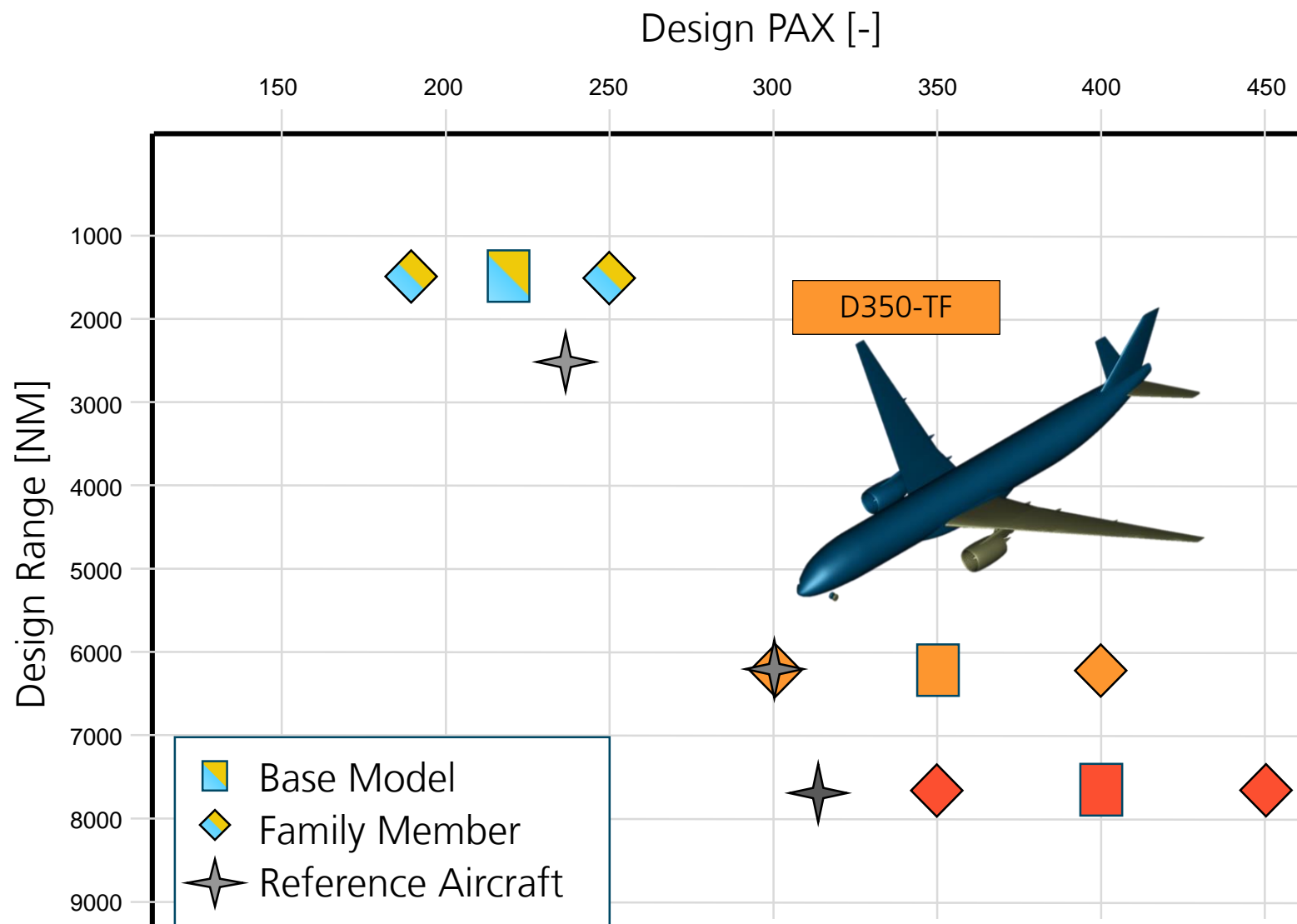
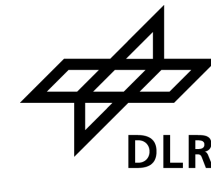

Mid- and Long Range: Baselines



Technology Factors		
Baseline	D400-TF	D350-TF
Reference	D-315	D-300
$\eta_{Gas\ Turbine}$	+10%	+9%
m_{Wing}	-5%	-20%
$m_{Fuselage}$	-5%	-10%
m_{Tail}		-3%
m_{Fold}		-30%
C_{D0}		-2%

Different Technology Assumption depending on the Reference Technology Level

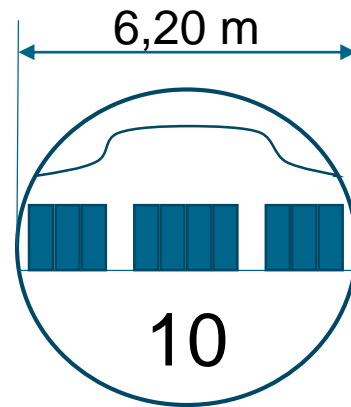

EIS 2050
D-400 TF

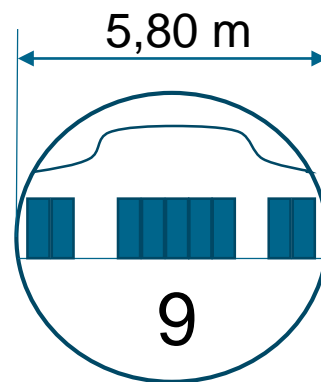
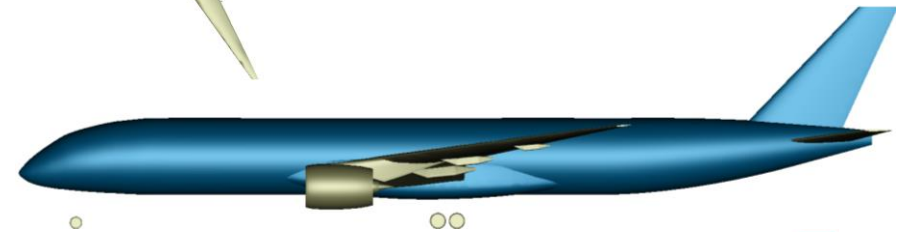
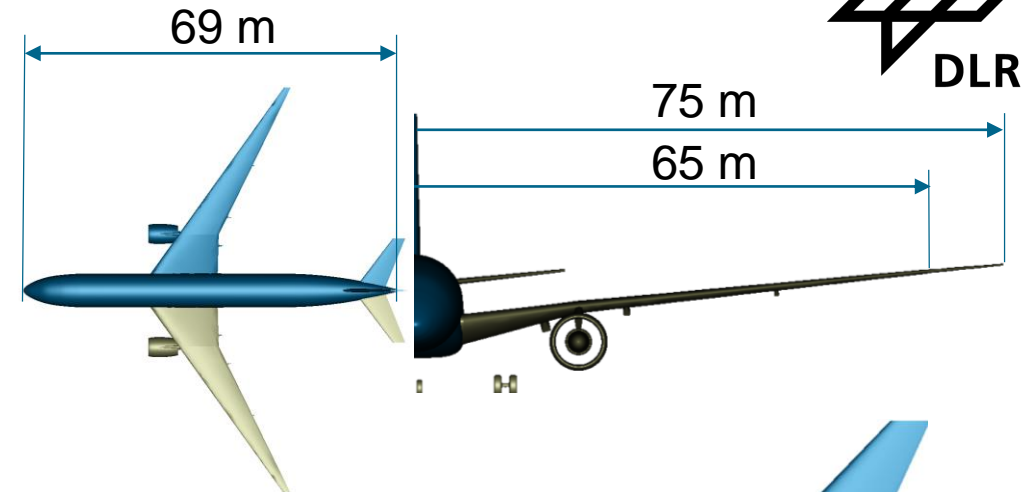

EIS 2045
D-350 TF

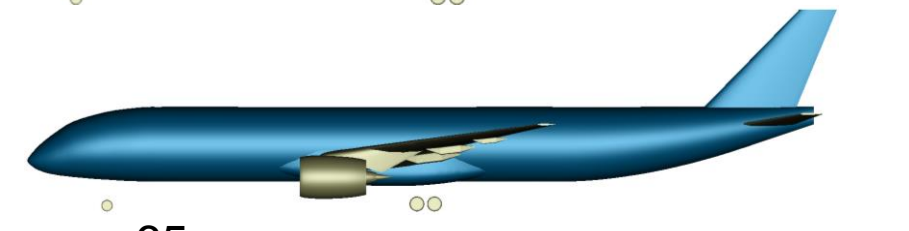
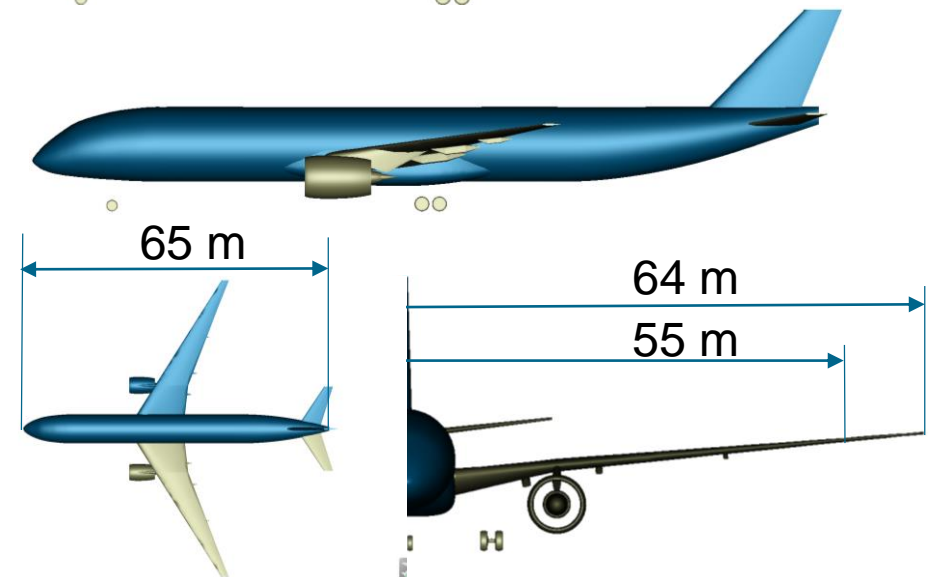

Aircraft Concepts Overview

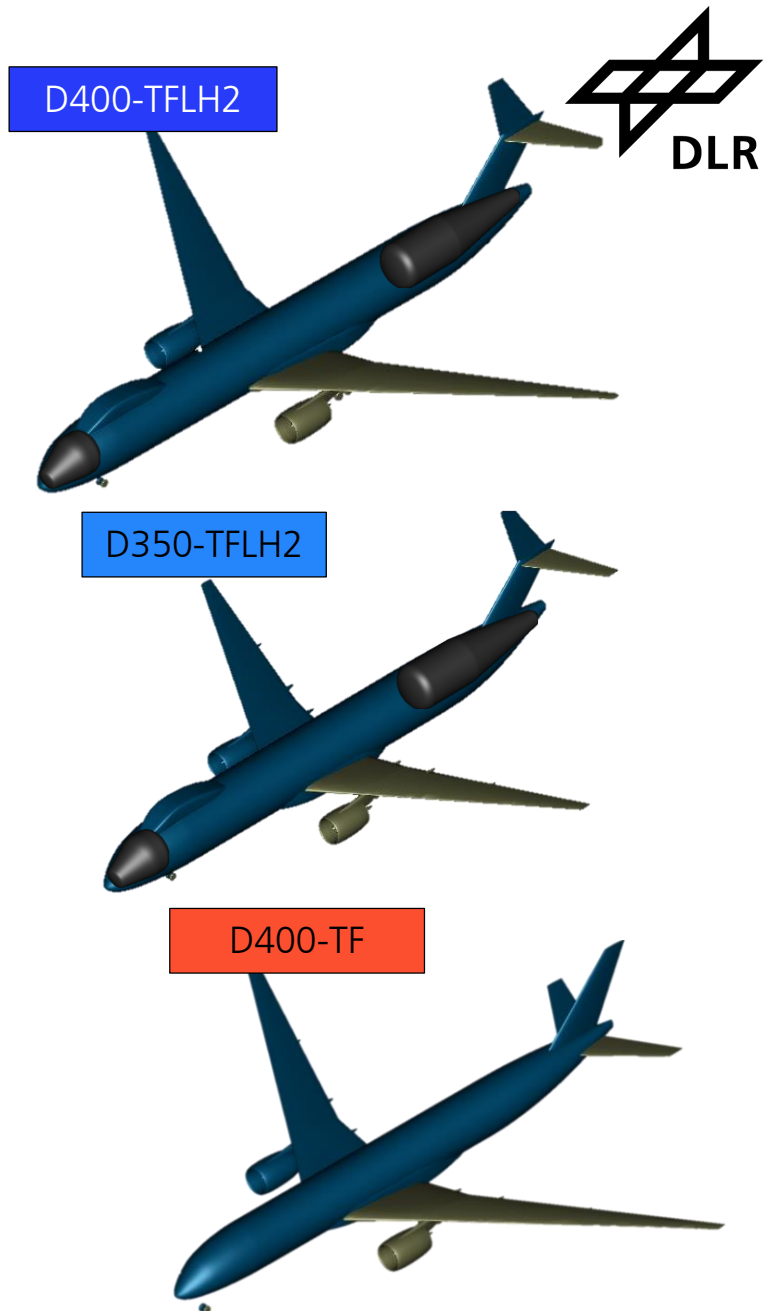
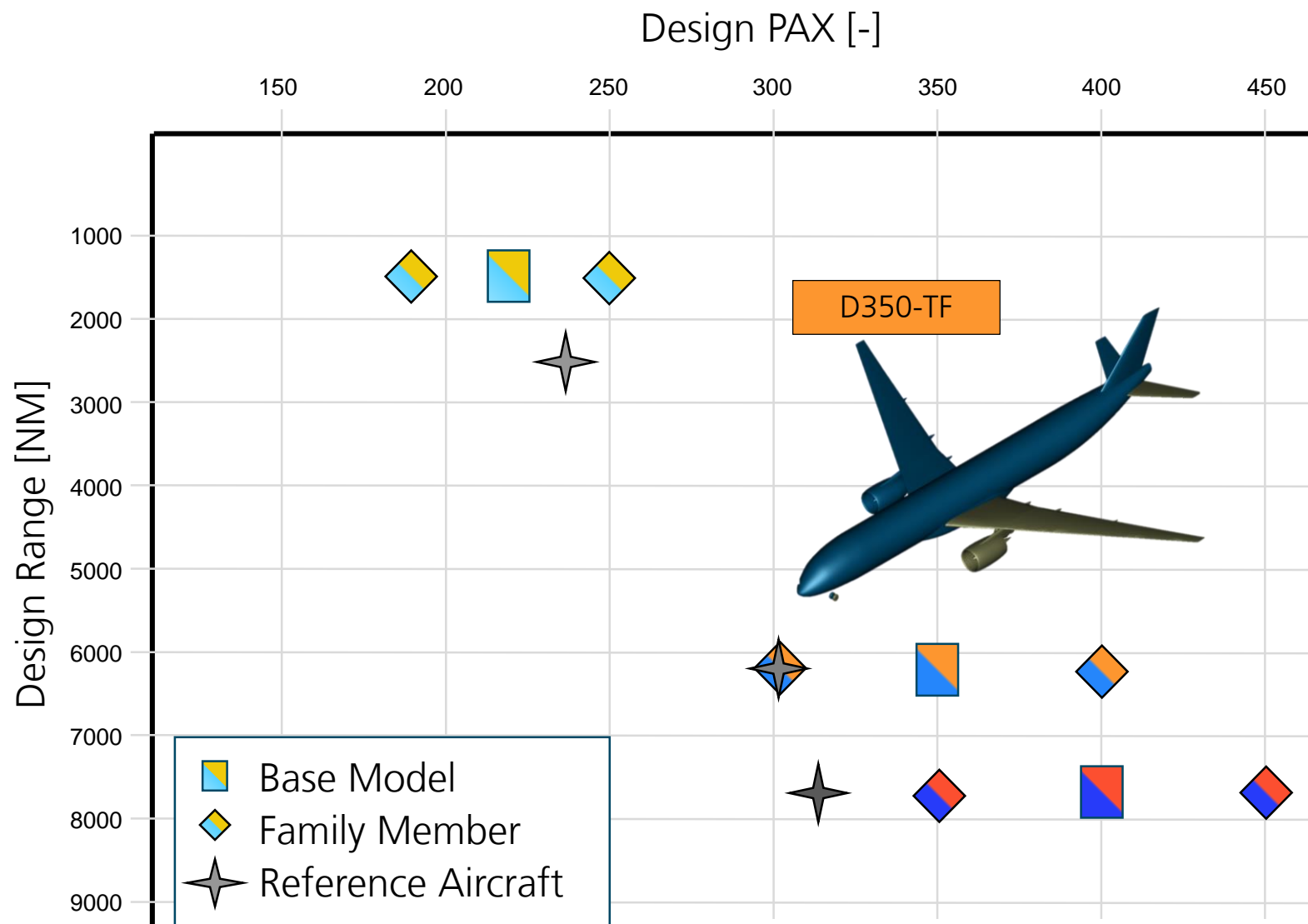

LH2 Mid- and Long Range: Tank Integration Concept

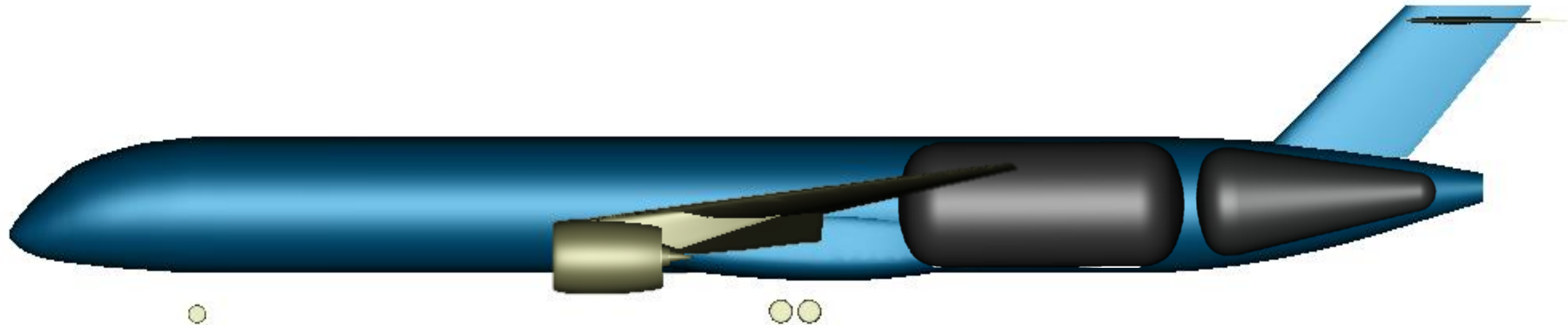
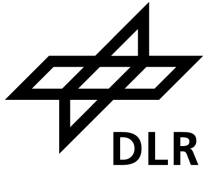

LH2 Mid- and Long Range: Tank Integration Concept



CS 25.772b:
Direct Entry to passenger from
pilot compartment [...]

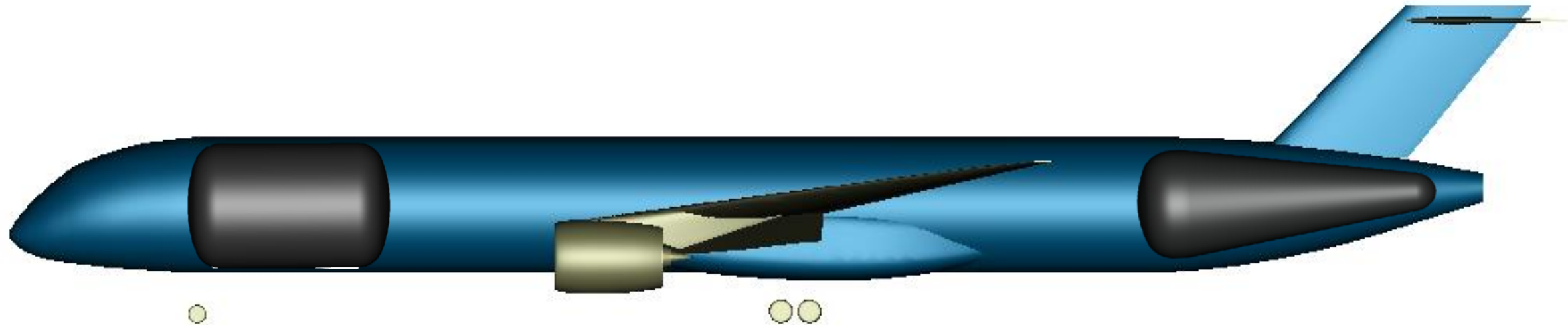

LH2 Mid- and Long Range: Tank Integration Concept

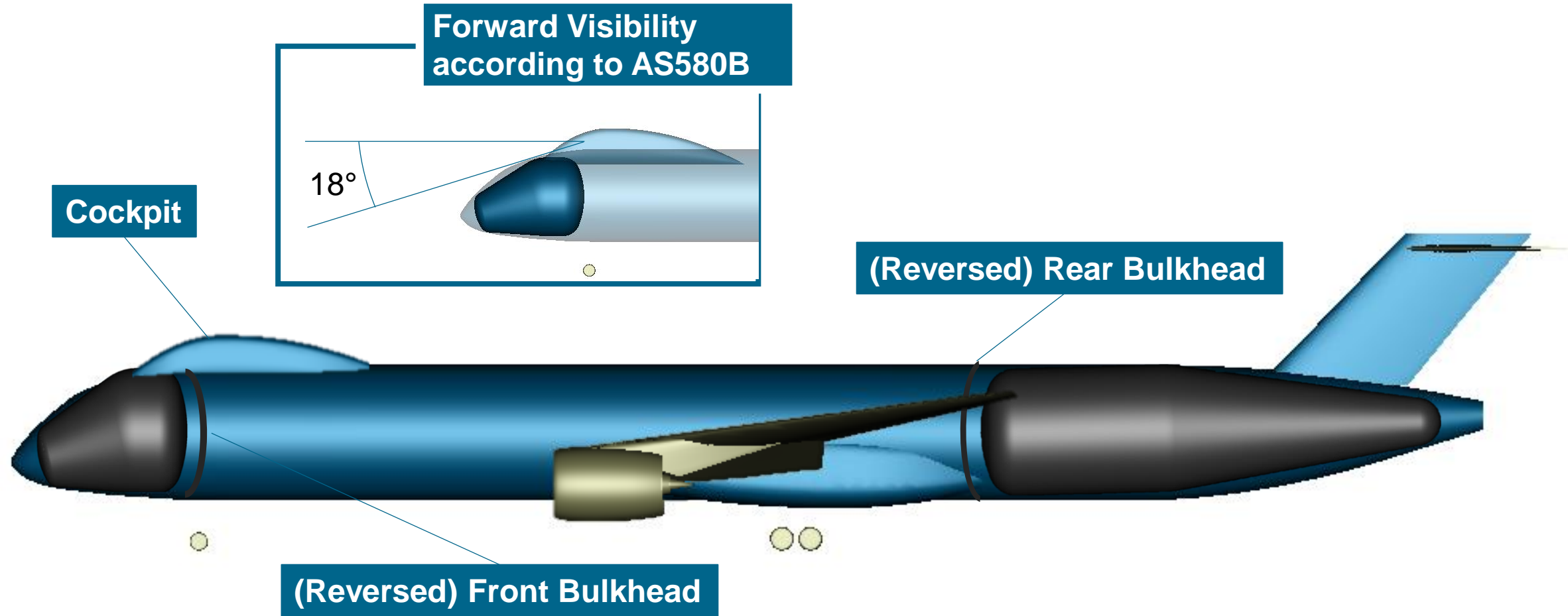

LH2 Long Range: D400TF-LH2

Technology Factors		
Designs	D400-TFLH2	D350-TFLH2
Reference	D400-TF	D350-TF
$\eta_{Gas\ Turbine}$	+3%	
m_{Wing}	+5%	
$C_{D0, Fuselage}$	+5%	
m_{VTP}	+500 kg	
$m_{FuelSystem}$	+100 kg	

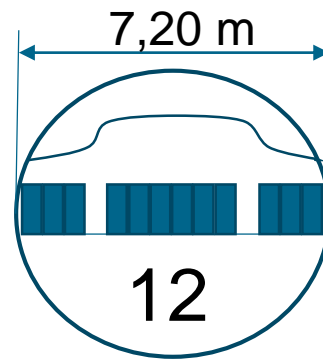

EIS 2050
D400-TFLH2

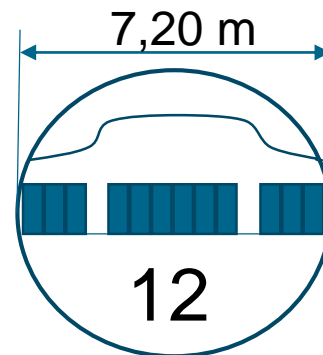
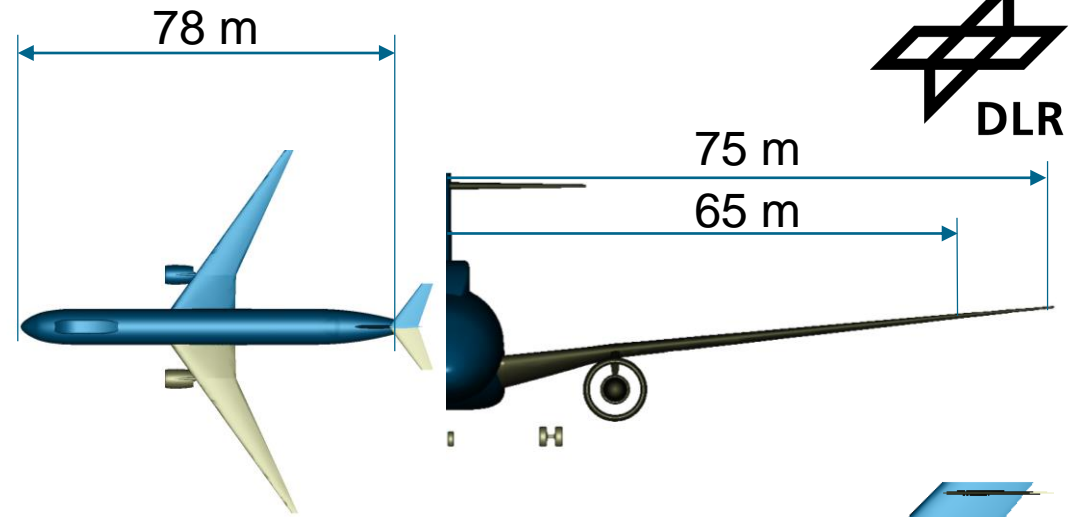

EIS 2045
D350-TFLH2

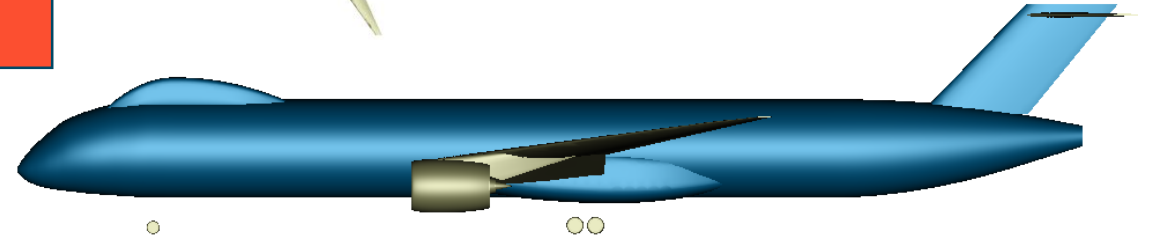



FIRST RESULTS

Long Range Aircraft Family Concepts: Block Energy Comparison

LH2-Aircraft weight is more constant compared to Synfuel Baseline

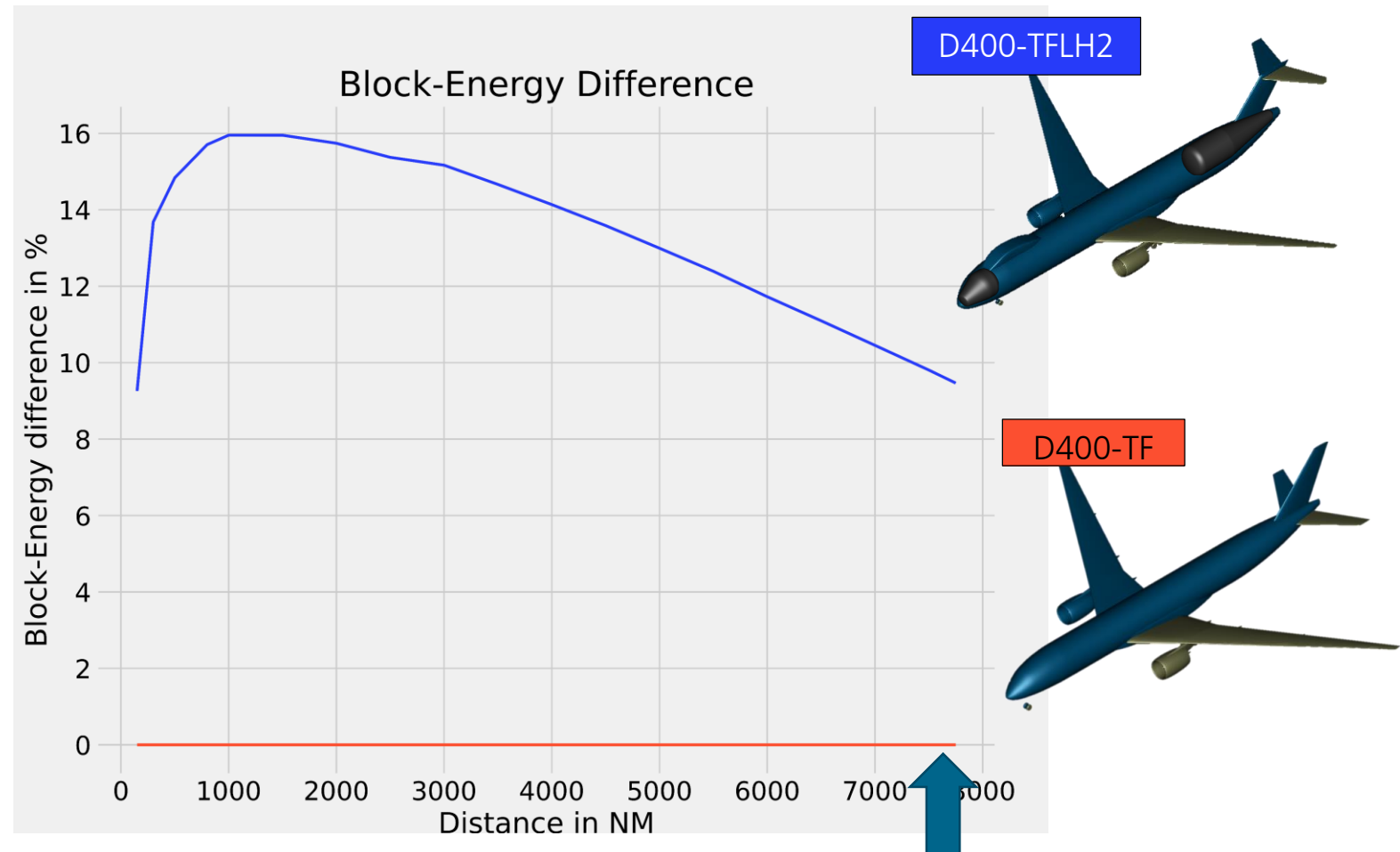
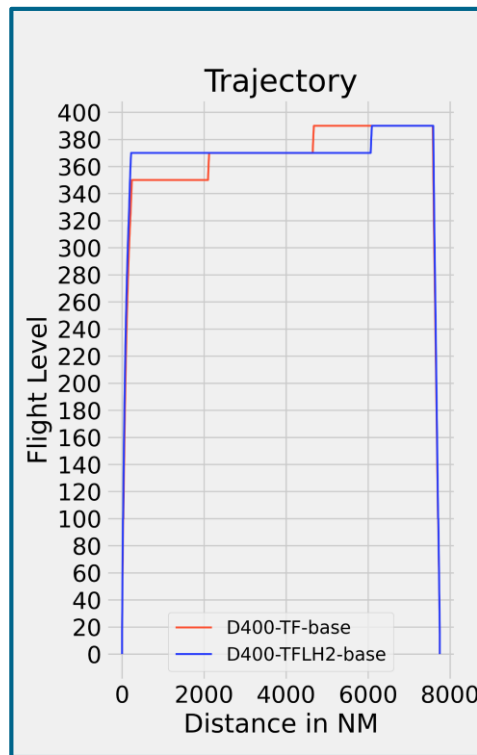

Long Range Aircraft Family Concepts: Block Energy Comparison

LH2-Aircraft weight is more constant compared to Synfuel Baseline

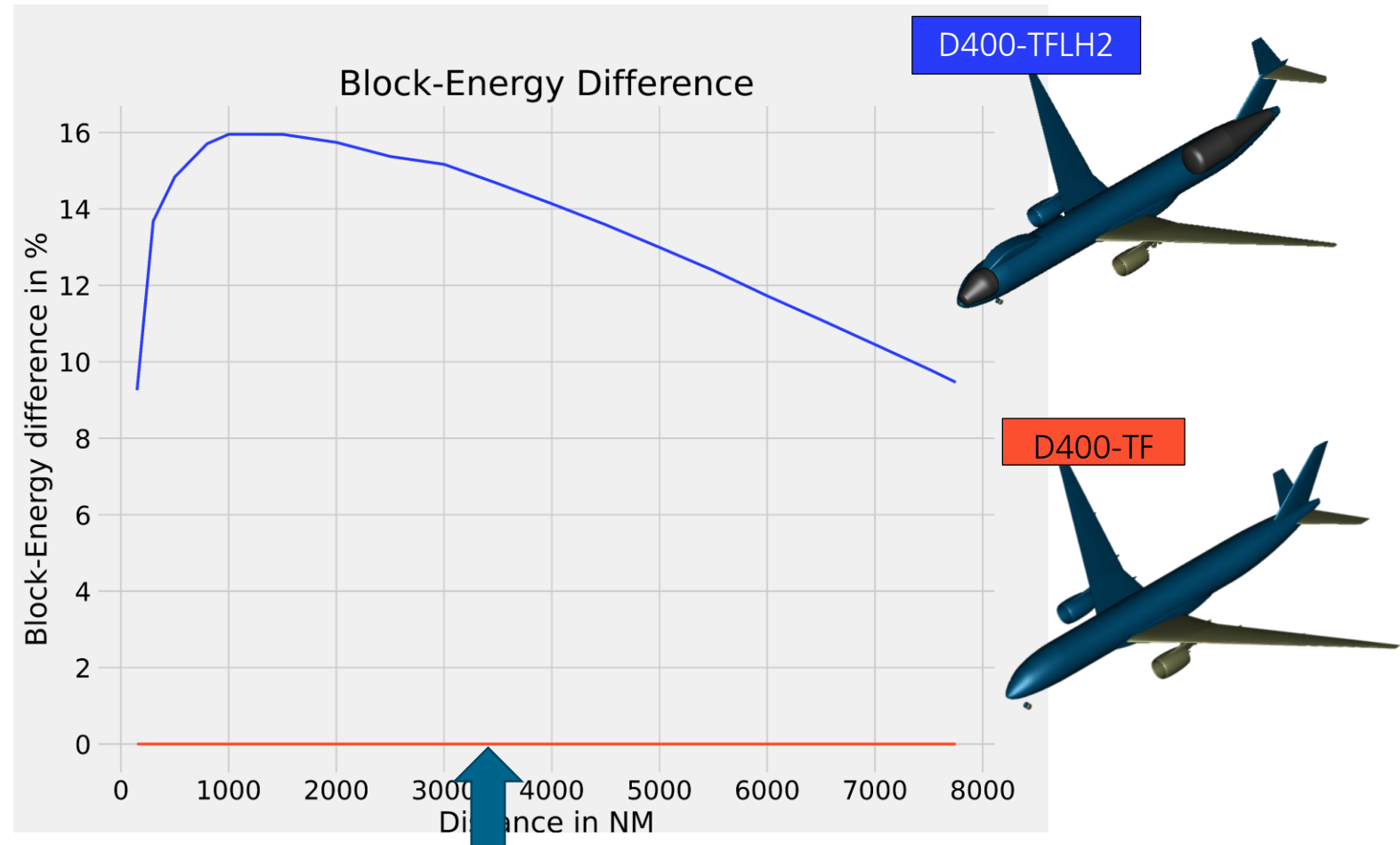
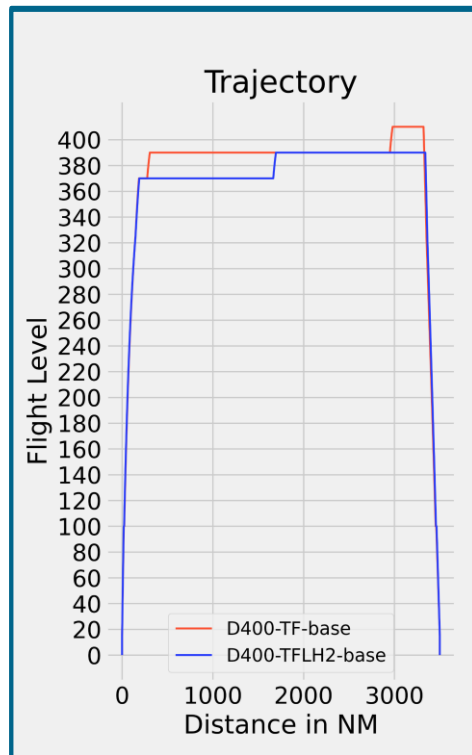

Long Range Aircraft Family Concepts: Block Energy Comparison

LH2-Aircraft weight is more constant compared to Synfuel Baseline

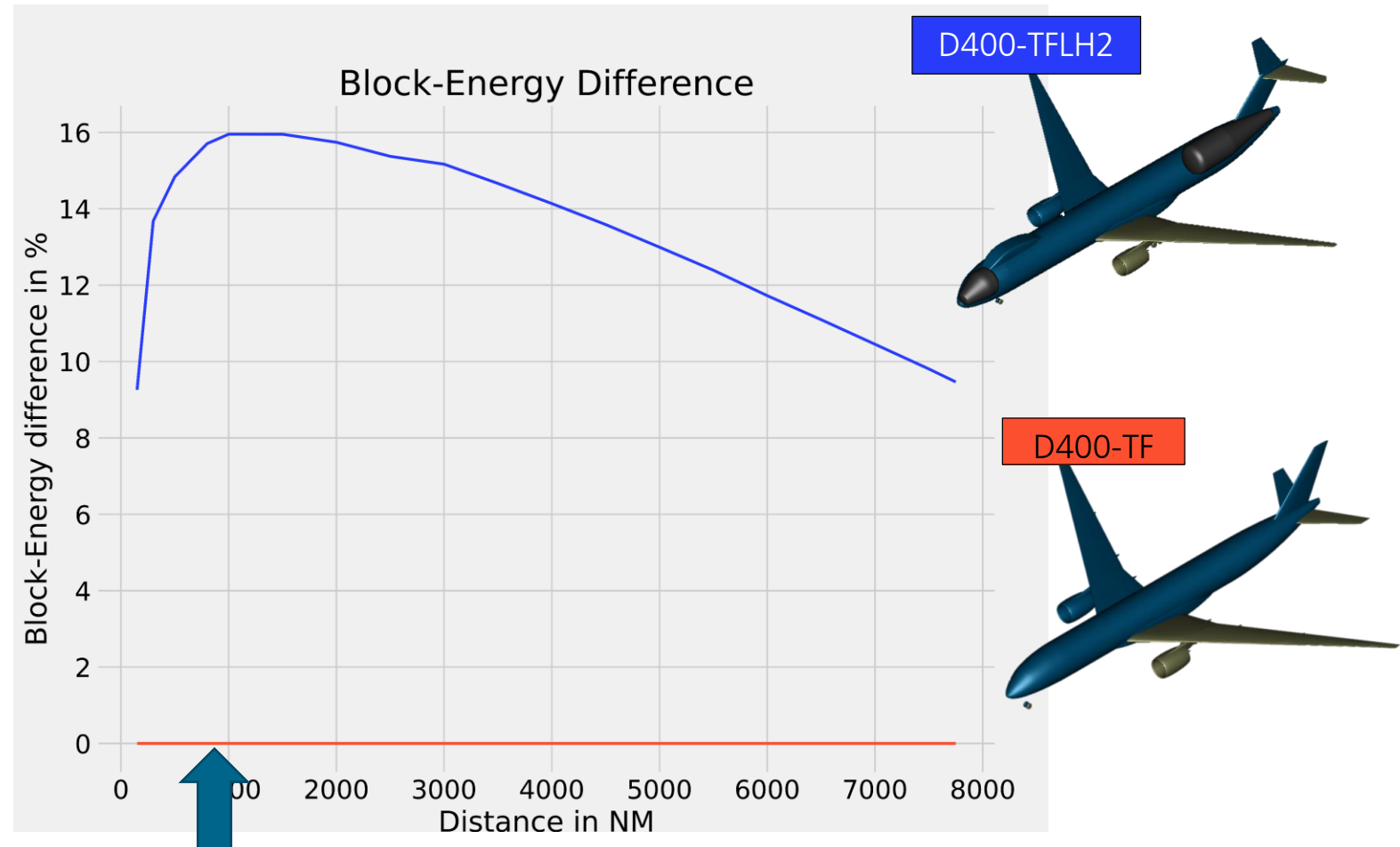
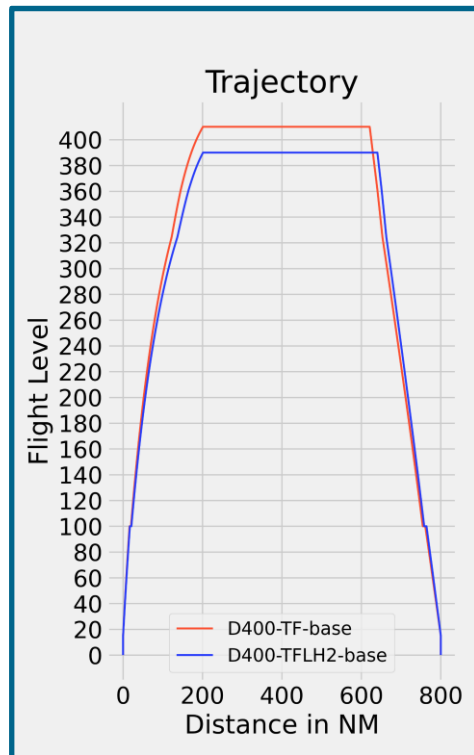

Long Range Aircraft Family Concepts: Block Energy Comparison

LH2-Aircraft weight is more constant compared to Synfuel Baseline

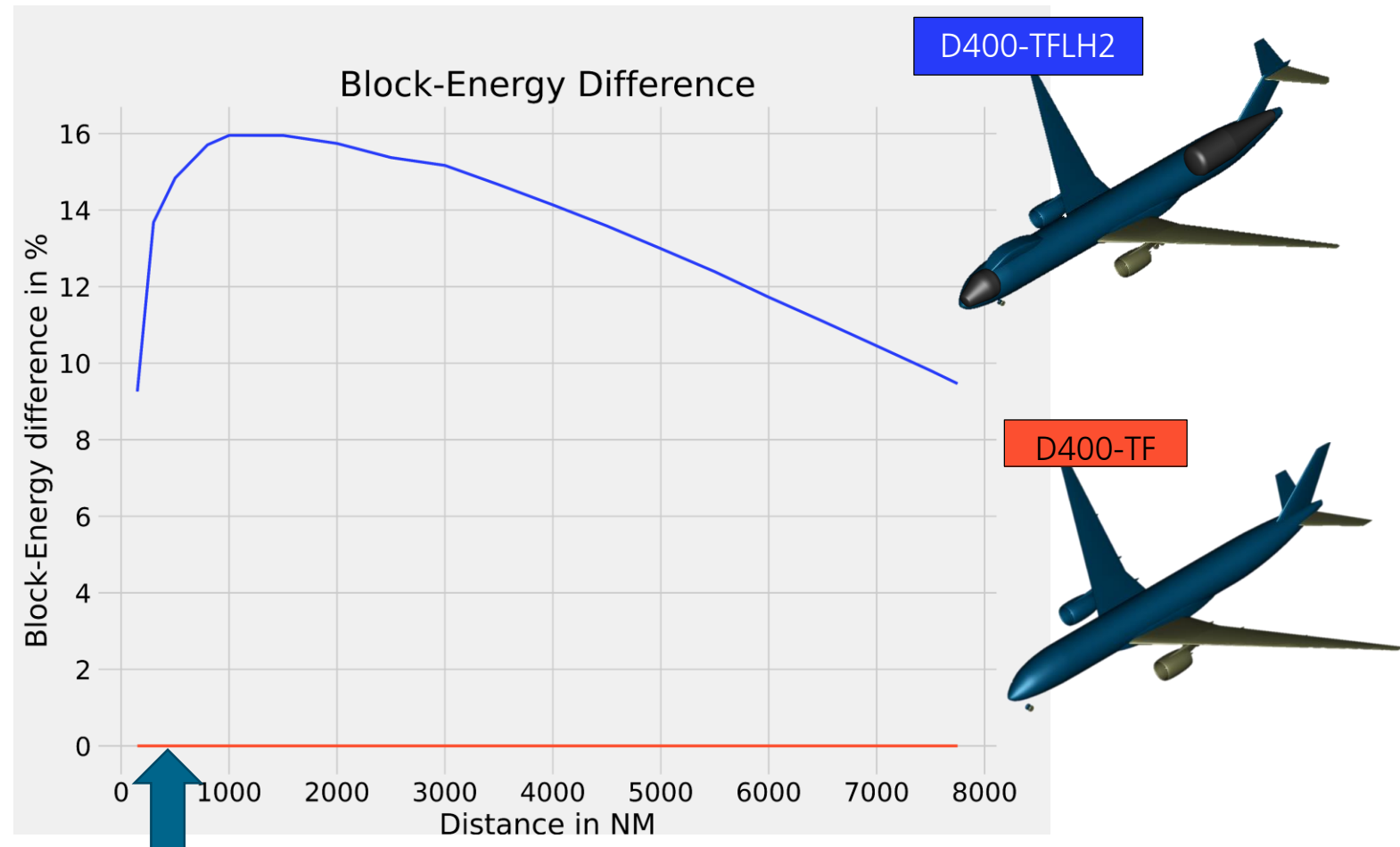
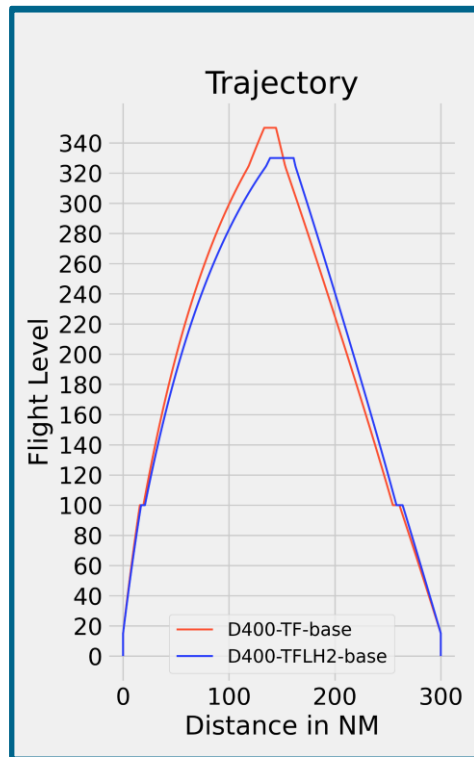

All EXACT Concepts: Block Energy Comparison

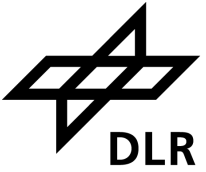

Turboprop most efficient compared to baseline

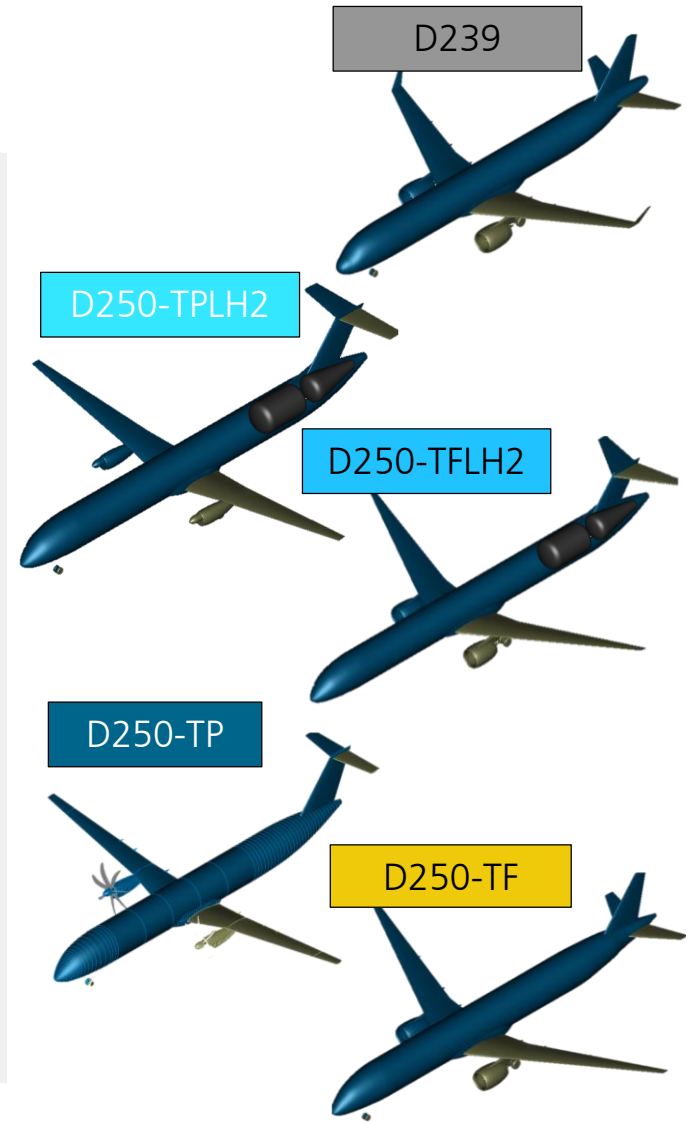
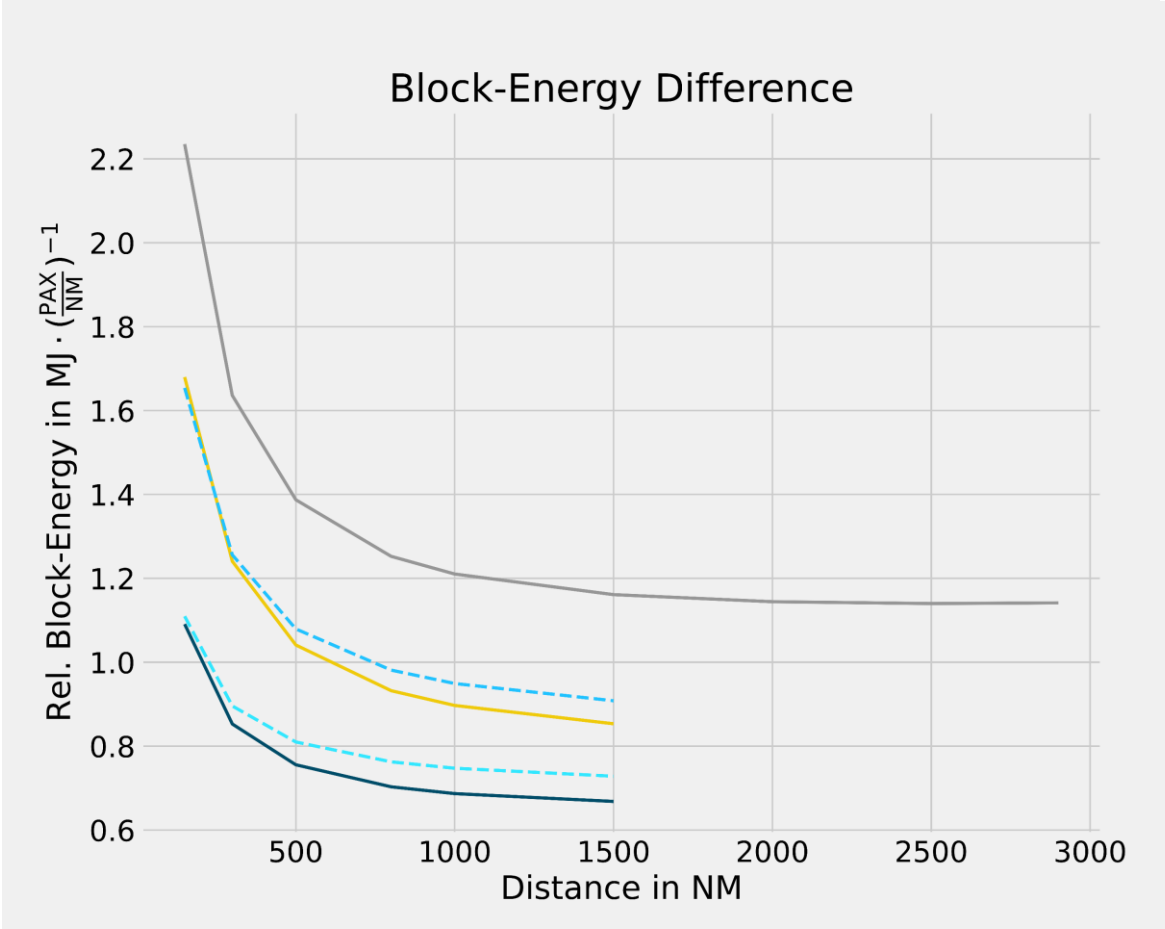

All EXACT Concepts: Block Energy Comparison



MHEP improves short range performance

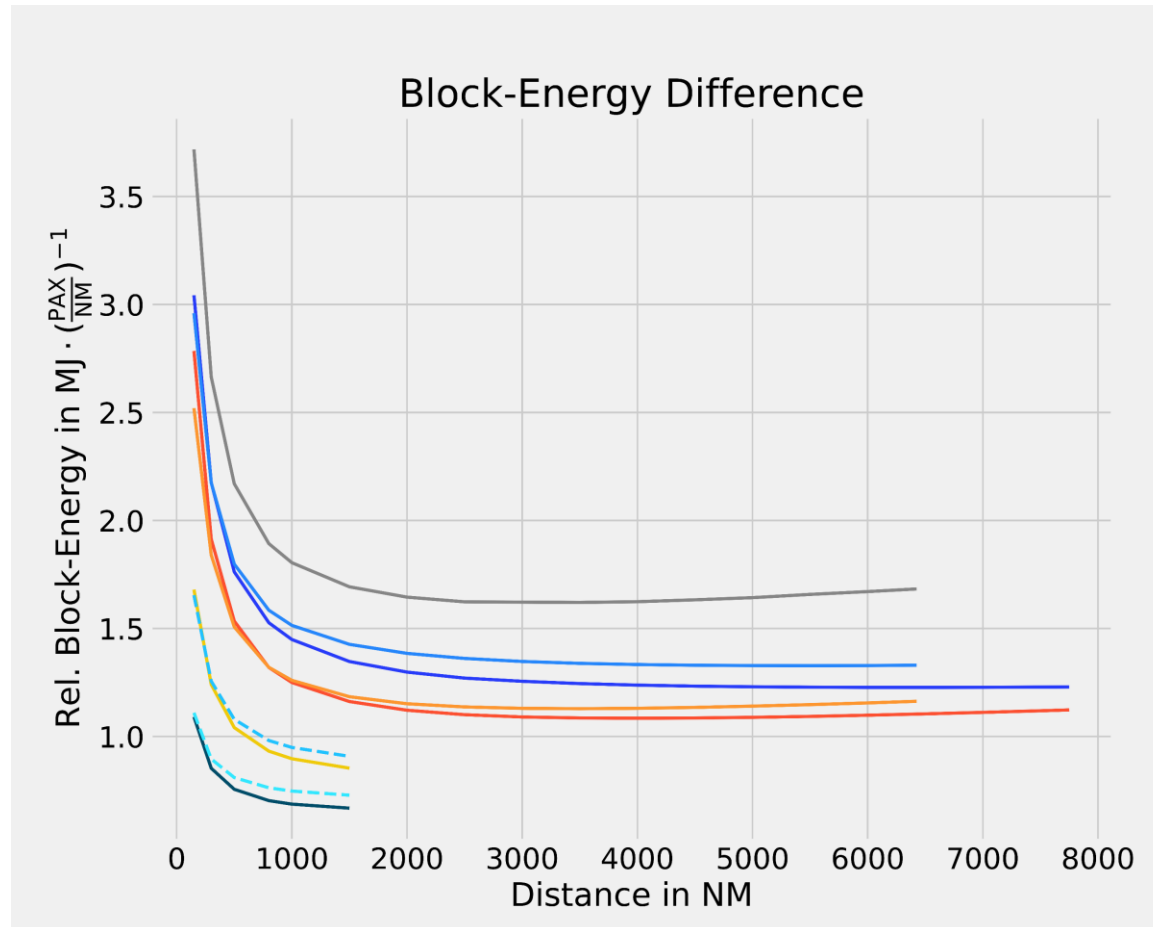

All EXACT Concepts: Block Energy Comparison

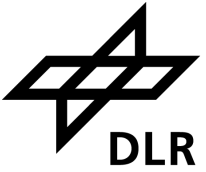

MHEP improves short range performance

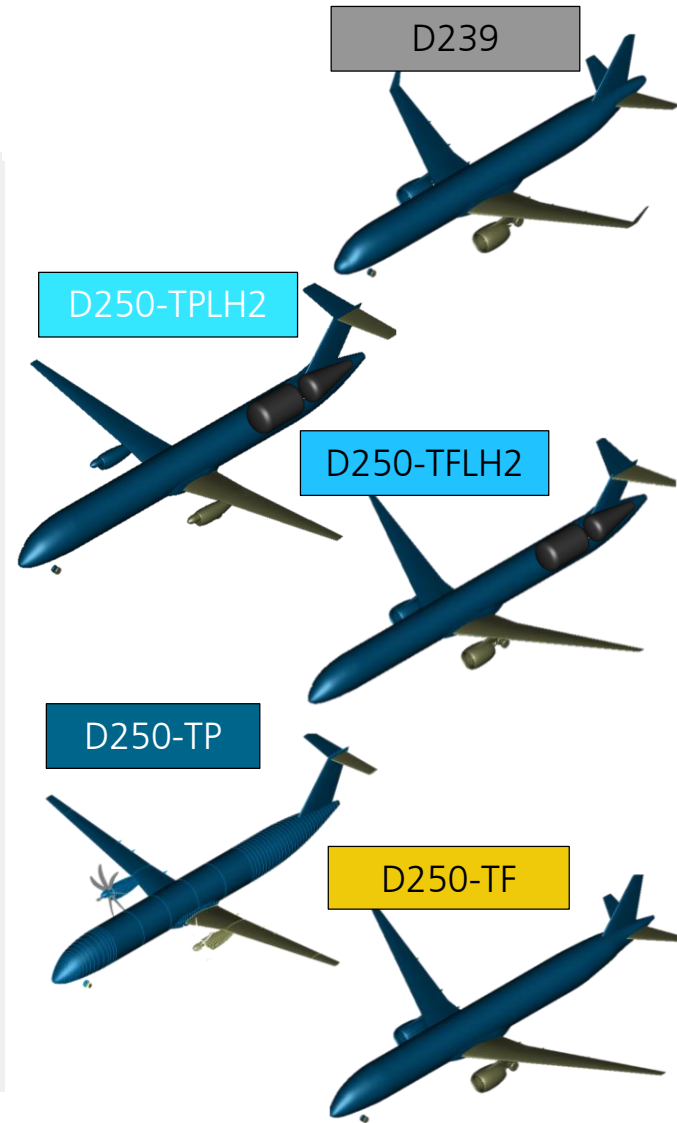
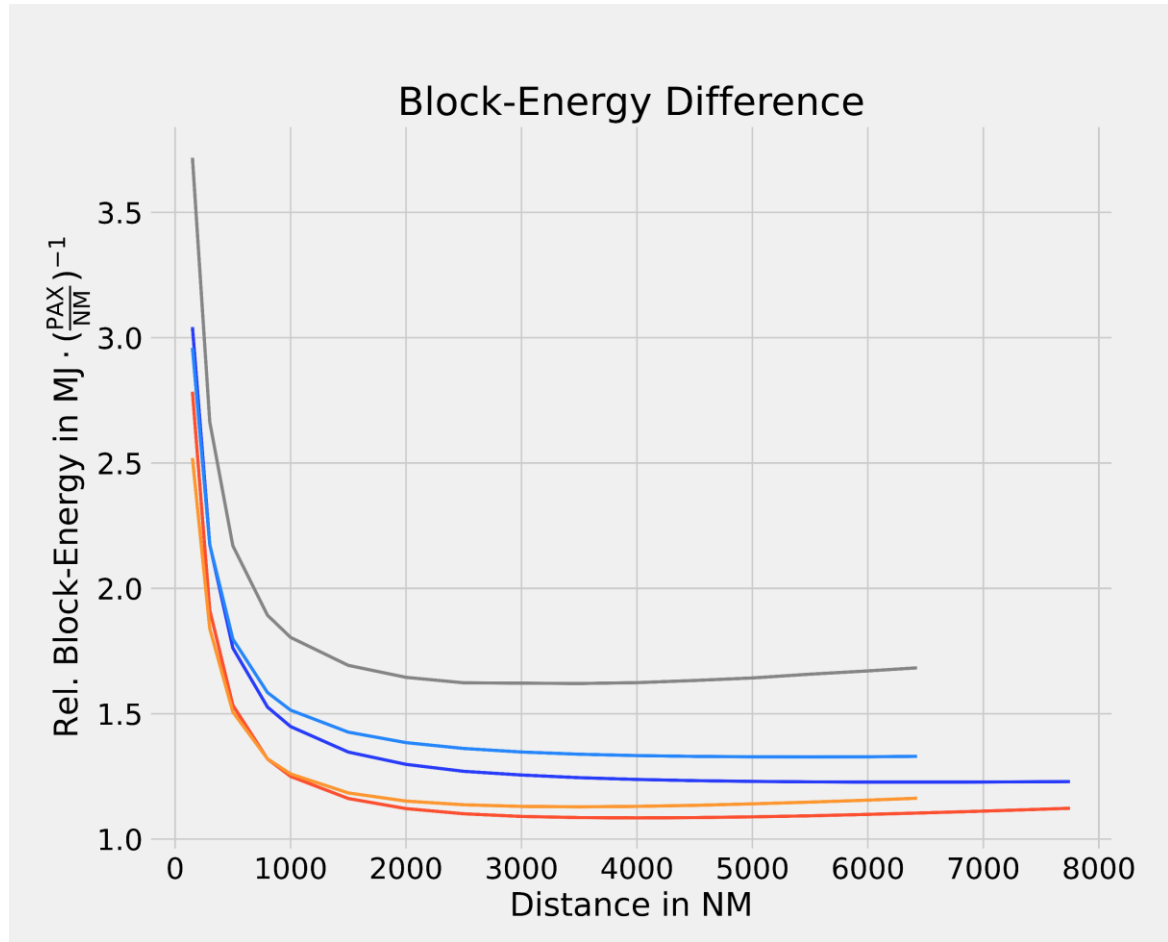
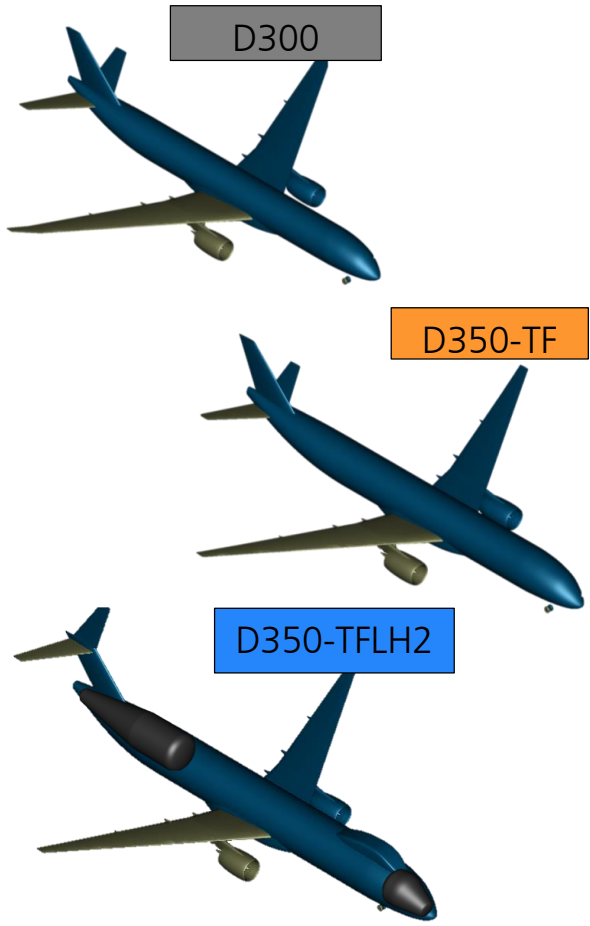

Demand Forecast



Increased Demand for Short Haul and High Capacity Aircraft

ASK-Anteil von Routen

Sitzplatzkategorie gemäß durchschnittlicher Sitzplatzanzahl auf Route

Daten aufbauend auf LV-LVE EXACT2 Forecast; inkl. flugleistungs- und kostengetriebener Neuzuordnung der Flugzeuge durch LV-BIZ

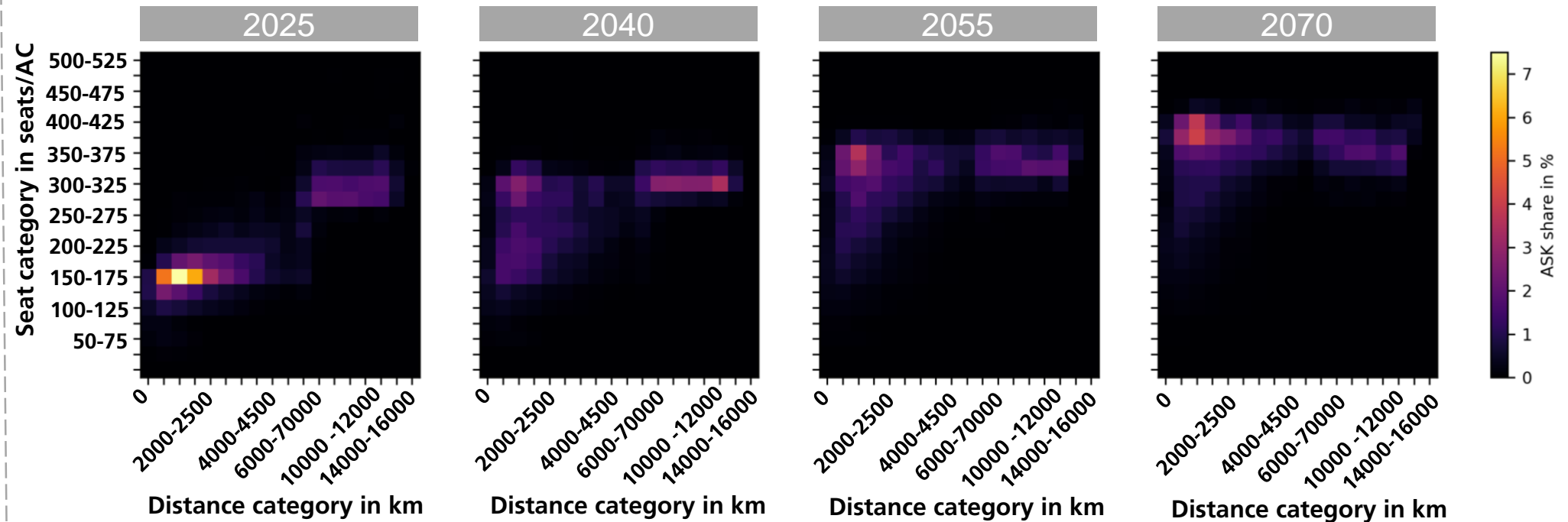

Source: Markus Kühlen, DLR-LV-LVE

First CFD Results – TAU

D250TF

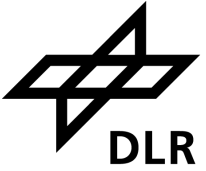

Changes in planform based on CFD-Results planned

Darstellung von Stromlinien

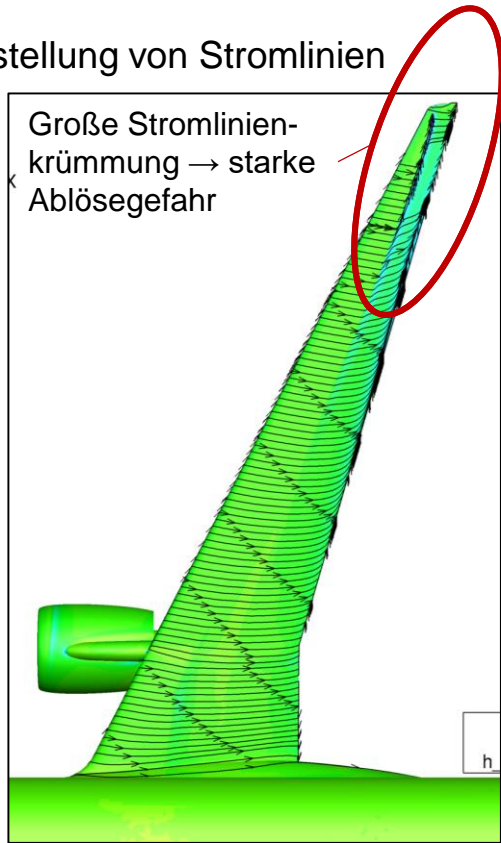

Source: Sven Geisbauer, DLR-AS

Darstellung von Ma=1-Isoflächen

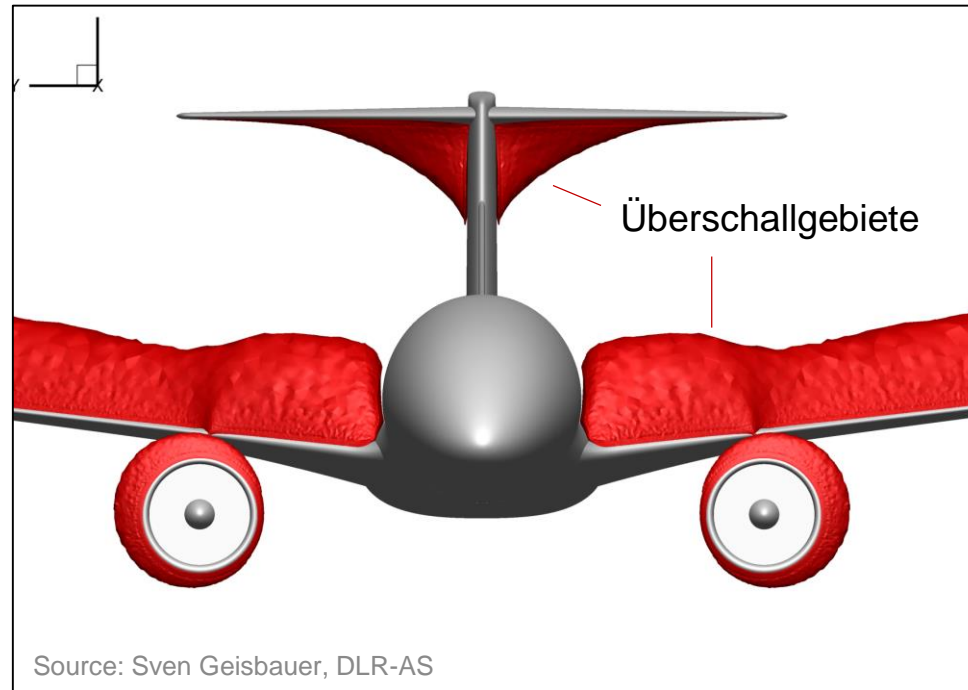

Source: Sven Geisbauer, DLR-AS

$Ma_\infty = 0.78, Re = 23 \text{ Mio.}, C_A = 0.588, \alpha = 2.42^\circ, \text{Power Idle, ungetrimmt}$

Darstellung von Stromlinien

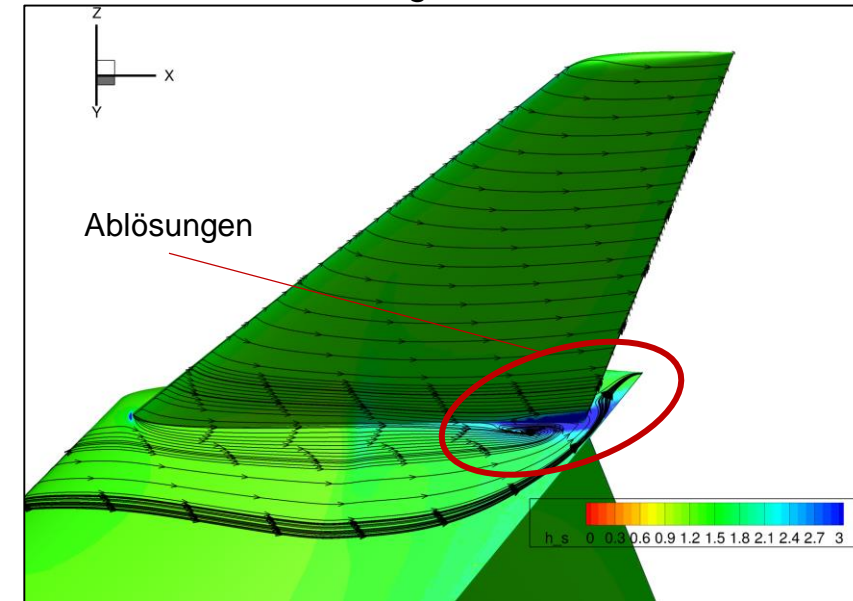

Source: Sven Geisbauer, DLR-AS



OUTLOOK

Potential Design Studies

- Reduce Uncertainties
 - Consider Trim Drag
 - More Automated Mid-Fidelity Tools
 - Wing Mass Estimation
 - Cabin (Length) Generation
 - Tailplane Sizing
- Configurational Down-Selection
- Aircraft Family Extension

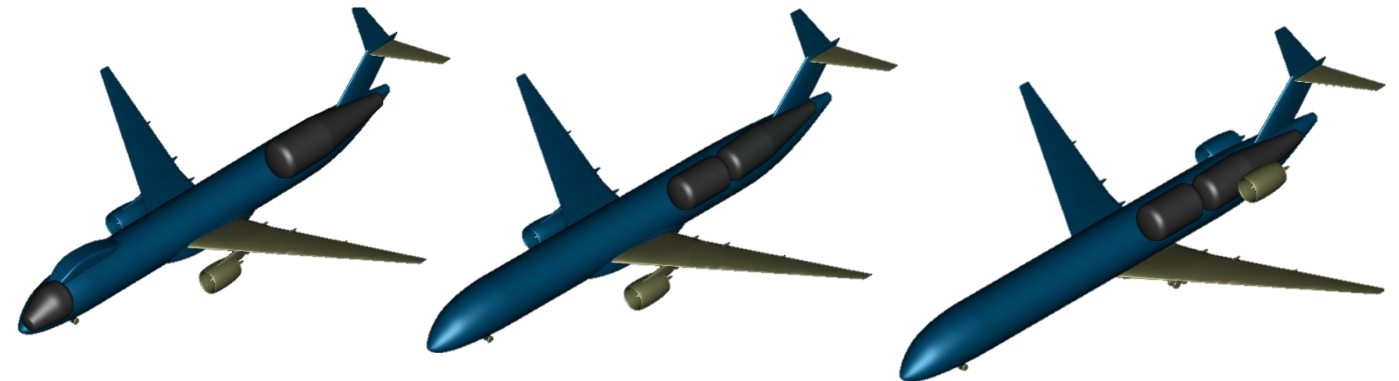
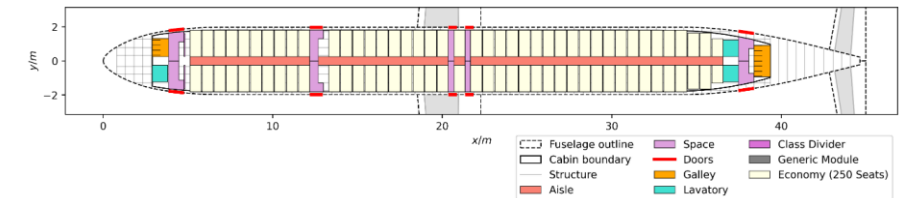
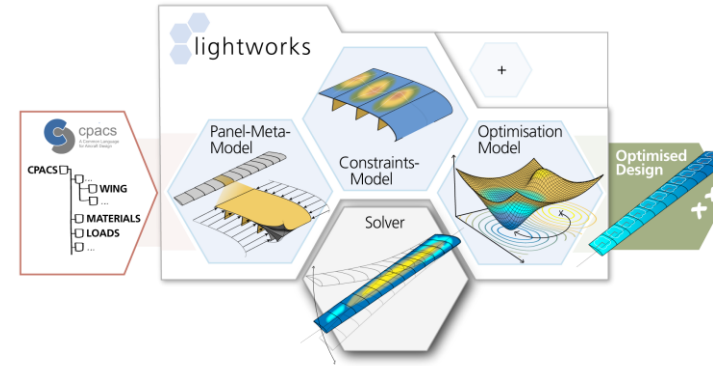



THANK YOU

Topic: **EXACT2:Short-, Mid-, and Long Range Aircraft configuration overview.**

DLRK 2024

Date: 2024-01-10

Author: Felix Fritzsche

Institute: DLR-SL

Image sources: All images “DLR (CC BY-NC-ND 3.0)” unless otherwise stated