



Paper 7814-A-2466

Improved Railway Performance by Maglev Derived Systems

Technological readiness and operational concepts in specific use cases of Maglev Derived Systems

Benedikt Scheier, German Aerospace Center (DLR)



Maglev Derived Systems 4 Rail (MaDe4Rail)

The aim of the project consortium



«The MaDe4Rail project aims to explore non-traditional and emerging **Maglev Derived Systems (MDS)** and to evaluate the technical feasibility and effectiveness to introduce MDS in Europe ...»

- > Technical Enabler & Technology components identification incl. risk & hazard analysis
- > Technical maturity assessment
- > Use Case identification & technical-economic feasibility studies

SCOPE

INFRASTRUCTURE MANAGERS/ TRANSPORT ADMINISTRATION



TECHNOLOGICAL DEVELOPERS



RESEARCH CENTRES/UNIVERSITIES



Full MDS vehicle



- Specific infrastructure
- Specific vehicles
- No technical integration with existing system

Hybrid MDS vehicle inter-operable with railway infrastructure



- Integrated in existing infrastructure
- Specific vehicles
- Technical and operational integration

Conventional rail vehicle upgraded with MDS sub-systems or technologies

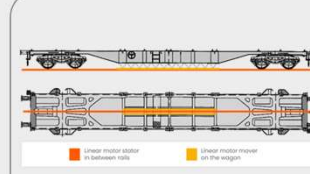

- Integrated in existing infrastructure and vehicles
- Single MDS components to improve the existing system

Agenda

- MDS – Overview
- MDS use cases
 - Rail vehicle upgrade
 - Hybrid air levitation
 - Hybrid magnetic levitation
- Multi-Criteria Analysis
- Results & Conclusion

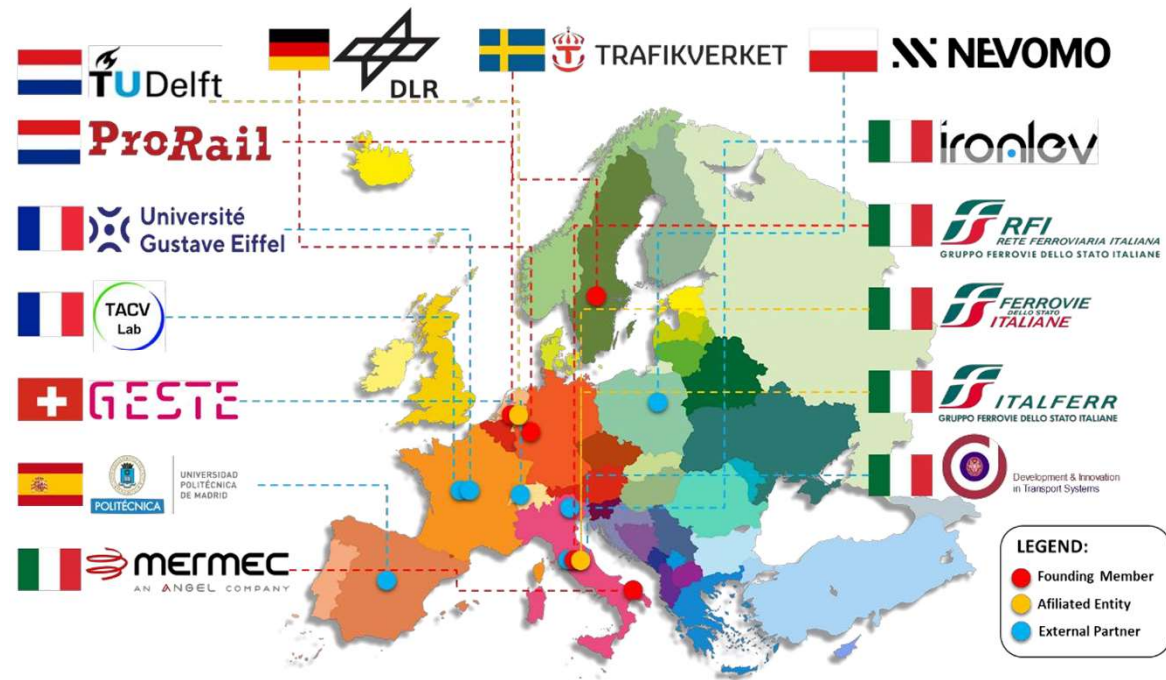

Geographical distribution of the members of the consortium

Maglev Derived Systems (MDS) Overview

- The aim is to find the best of both worlds by combining conventional rail systems with magnetic and air levitation technologies.
- Based on a detailed Technology Readiness Analysis (TRA) of existing systems and publications [1], several use cases were identified and described. Three use cases were selected for further detail using Multi-Criteria Analysis (MCA).

Use cases for MDS with high potential:

1. Rail vehicle upgraded MDS configuration - incline pusher,
2. Hybrid MDS based on air levitation configuration,
3. Hybrid MDS based on magnetic levitation configuration.

Maglev Derived Systems Use Case Analysis

- The “conventional railway upgraded – incline pusher”
 - Rail track and vehicle upgraded MDS
 - Minimal modifications of rail infrastructure and vehicles
 - Linear motors at specific track locations improve performance in e.g. driving uphill gradients or improving traction for low adhesion cases
- MDS with focus on magnetic propulsion
 - Combination with levitation while keeping the rail as guidance technology, e.g. during switch crossing
 - The “**hybrid maglev**” is using magnetic levitation and propulsion
 - The “**hybrid airlev**” is using air levitation technologies known as well as tracked hovercraft or tracked air-cushion vehicles

Use case analysis considering two scenarios:

- Scenario A) MDS with minimum requirements and impact on current infrastructure
- Scenario B) MDS with needed adaptations to fully exploit the maximum performance

Rail vehicle upgraded MDS configuration - incline pusher

Propulsion system – linear synchronous motor (LSM):

- Stator installed between existing rails fixed to sleepers or slab track
- permanent magnets attached to the vehicles
- Control centre command the linear motor
- Inverter stations deliver power to the linear motor
- Conventional rail-wheel contact without any changes

Vehicle:

- Conventional vehicles updated with a mover magnet
- IMU, GPS, and other self-diagnostic sensors within the vehicle
- dedicated on-board battery serves as main power source
- Anti-collision system with radar sensor facilitates safe braking

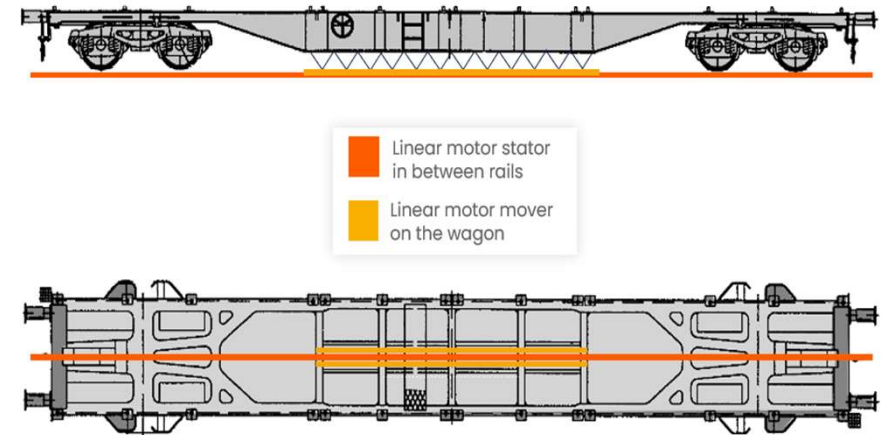

Figure 4 - Principle of updated conventional freight wagon (source: NEVOMO)



Figure 5 - Example of mounted mover magnet on conventional intermodal rail wagon (source NEVOMO)

Rail vehicle upgraded MDS configuration incline pusher

Scenario A „existing line“:

- Scenario to evaluate the implementation of an existing line with rail vehicle upgraded MDS technology.
 - Evaluation of the new technology on the basis of the minimum achievable requirements.
- Capacity increase in mixed-traffic through higher speed for freight trains!

Scenario B „new line“:

- Scenario to evaluate the implementation of the MDS technology for the design and construction phases of new line.
 - Evaluating which applications and needs are required to achieve maximum fulfilment.
- Cost-savings for new infrastructure!

Rail vehicle upgraded MDS configuration incline pusher

Use case scenario A (existing line):

- Max. speed passenger trains 140 kph
 - Max. speed freight trains 85 kph
 - 1300 tons freight trains
 - Max. gradient 17 ‰
 - With MDS: higher speed of freight trains
- Capacity increase in mixed-traffic through higher speed for freight trains!

Use case scenario B (new line):

- High speed passenger trains
 - Max. speed 250 kph
 - Train power 1.6 MW
 - Train power with incline pusher 4.1 MW
 - Max. gradient increase from 25 ‰ to 45 ‰
 - With MDS: Use of significantly higher slopes → Optimisation of earthworks and track construction
- Cost-savings for new infrastructure!

Hybrid MDS based on air levitation

- Principle of air levitation based on creating a **pressure differential** between air inside and outside an air chamber
- Sufficient **mechanical force to lift a vehicle off the ground**
- Proven technology already used on several lines in the past
- A significant improvement of the concept proposed is the new propulsion method, namely, electro-dynamic wheels (EDW, rotating magnets)

Goals:

- Increasing rail capacity
- Friction needs to be reduced/eliminated
- New train concepts must operate together with the existing train system

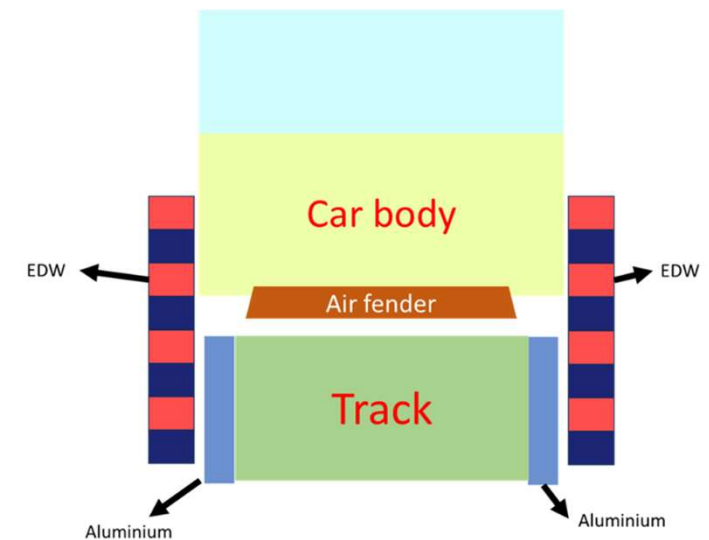
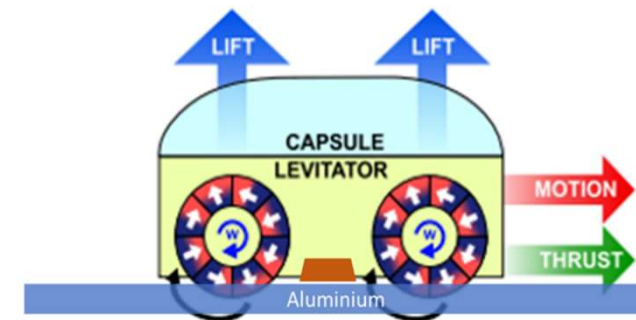

Figure 6 Schematic levitation by air (fenders) and propulsion by rotating permanent magnetic wheels.

Hybrid MDS based on air levitation

- The technology can be designed to transport **both passengers and cargo**.
- The trains use electro-dynamic wheels for smooth and **rapid acceleration and deceleration**, ensuring timely adherence to schedules.
- Airlev mechanism creates an ultra-thin layer of air for levitation, **drastically reducing noise, friction and wear**.
- The nearly frictionless movement, combined with efficient propulsion, results in **reduced energy costs**.
- The airlev bogie could be installed in **any kind of rail transportation vehicle**, such as metro vehicles, freight trains, etc.

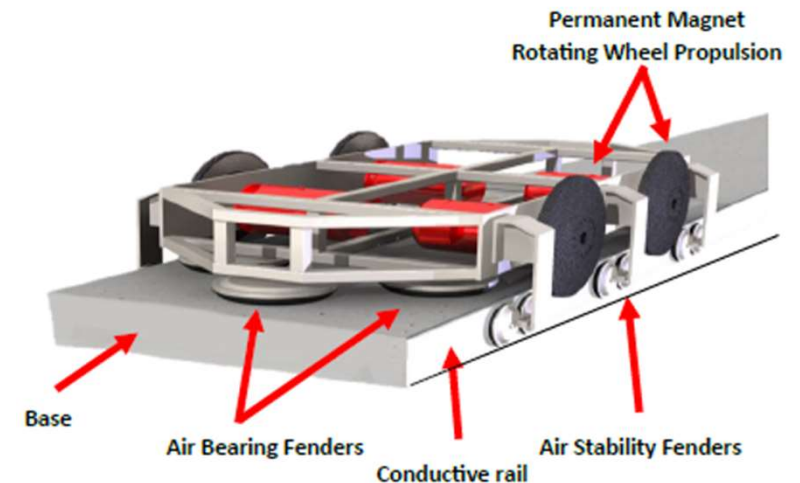

Figure 8 Proposed bogie, schematically, combining load carrying by air levitation and rotating permanent magnet wheel for propulsion/braking.

Hybrid MDS based on air levitation

Scenario A:

- The air levitation train runs on top of a slab with stator strips for propulsion and braking in between the existing rails.

Scenario B:

- The air levitation train runs on top of a slab. It is the ideal to **maximize the performance (stability)** of the air levitation system.

Because of the minor difference between the scenarios, the feasibility study has been developed only for Scenario A.

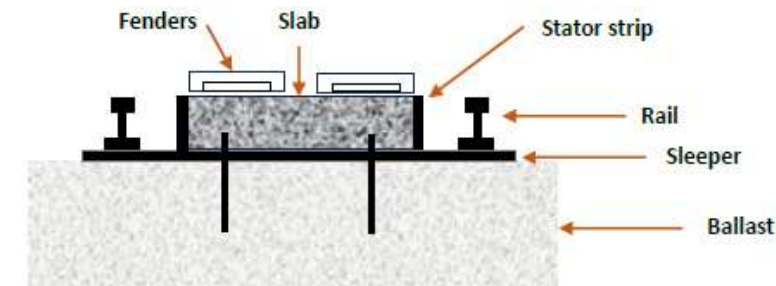

Figure 9 Track for conventional trains and air levitation trains

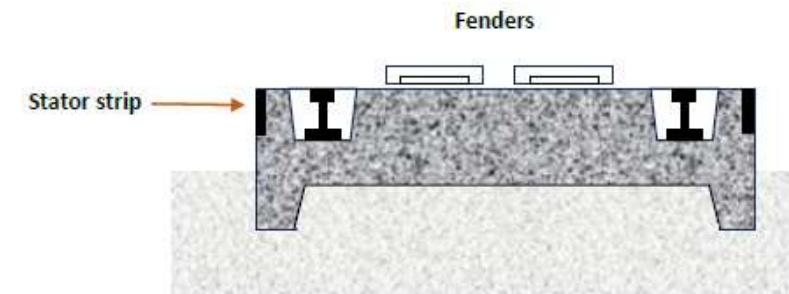

Figure 10 Ideal track for air levitation trains that also allows conventional train to run on

Hybrid MDS based on air levitation

Use Case scenario A:

- Historical line in Italy connecting two urban centers, each with over 200,000 inhabitants
 - Length: 40 km
 - Max gradient: 4.5 ‰
 - Max. speed passenger trains: 180 kph
- Expected benefits: better energy efficiency and reduction in noise and dust contamination

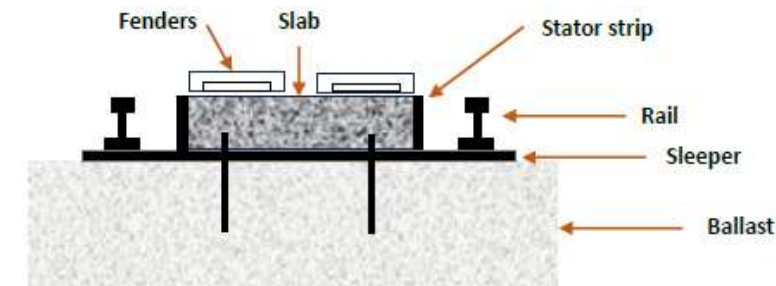

Figure 9 Track for conventional trains and air levitation trains

Hybrid MDS based on magnetic levitation

- On magnetic levitation systems it operates on dedicated maglev corridors
- The vehicle can operate on wheels during switch crossing or platform approaching
- The cant can be increased for higher speed in curves

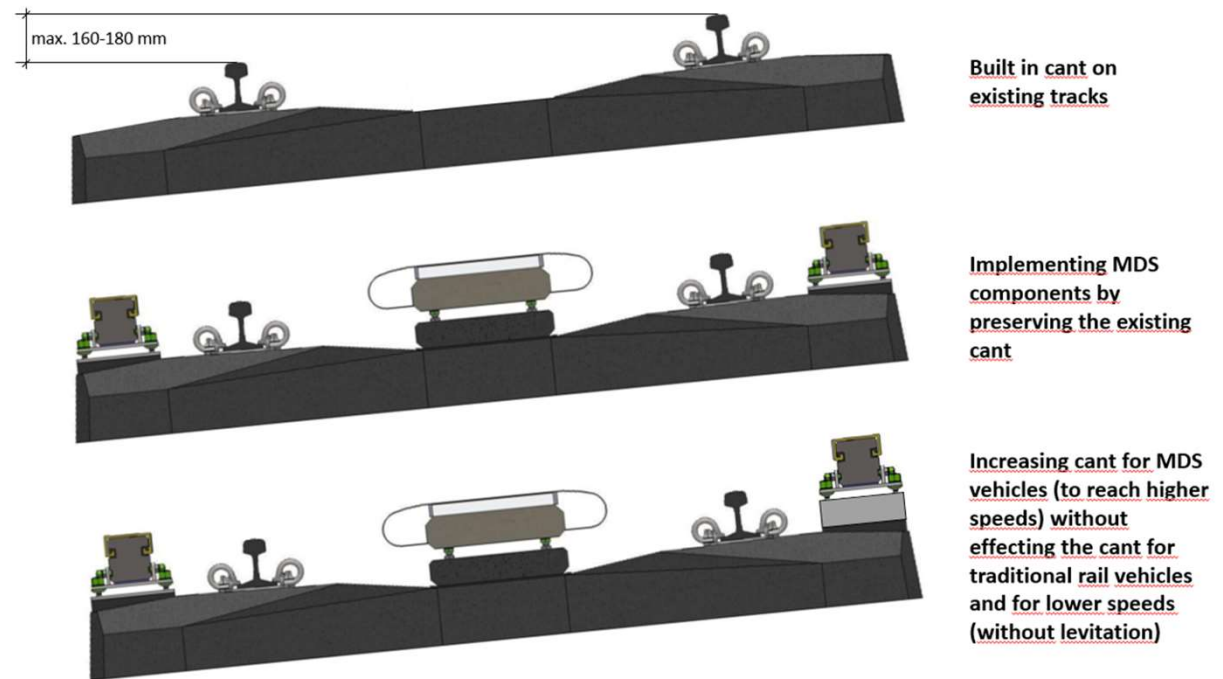

Figure 14 Implementing additional cant for MDS vehicles

Hybrid MDS based on magnetic levitation

Propulsion system – linear synchronous motor (LSM):

- Stator installed between existing rails fixed to sleepers or slab track
- permanent magnets attached to the vehicles

Levitation and guidance system:

- Sliders with permanent magnets and lateral stability system levitation directly applied to standard existing tracks (scenario A)
- Ferromagnetic levitation beam attached outside the rails fixed to the sleepers or slab track (scenario B).

Vehicle:

- New designed lightweight pods to carry 70 people and achieve speeds up to 250 kph
- Interoperable with existing infrastructure



Figure 15 Example of custom rails adopted in combination with traditional wheeled systems (source: IRONLEV)

Hybrid MDS based on magnetic levitation

- Hybrid MDS on an historical regional line as an alternative to constructing new HSR line
- Number of stations: 16
- Length: 560 km
- Maximum speed: 180 kph
- Max gradient: 15 ‰
- MDS pods can reach max. speed on higher cants: 250 kph

Further study of this use case analysis:

- Comparative analysis of capacity on both lines: conventional high-speed trains on HSR line and MDS pods on upgraded regional line
- Average reduction in travel time of 25 %; more energy consumption of 15 %

Multi-Criteria-Analysis (MCA)

High weighted sub-criterias:

- Technical feasibility
- Impact on existing infrastructure
- Interoperable with existing service
- Type of service

CRITERIA		SUB-CRITERION			System configuration				
Definition	Weight (%)	Definition	Unit of measurement	Weight (%)	Pure Maglev	Hybrid Air-levitation	Hybrid Mag levitation	Rail vehicle upgraded	
TECHNOLOGY	40,00	1.1	Technical Complexity	Range [1(Low)-5(High)]	10,00	5	4	4	3
		1.2	Technical Feasibility	Range [1(Low)-5(High)]	30,00	5	2	4	4
		1.3	Impact on the existing infrastructure	Range [1(Low)-5(High)]	30,00	5	2	2	2
		1.4	Scalability or Adaptability	Range [1(Low)-5(High)]	10,00	1	4	4	5
		1.5	Possibility of installing on existing railways	Range [1 (Yes) or 0 (No)]	20,00	No	Yes	Yes	Yes
INTEROPERABILITY	20,00	2.1	Interoperable with existing Service	Range [1 (Yes) or 0 (No)]	90,00	No	Yes	Yes	Yes
		2.2	Interoperability with future hyperloop	Range [1 (Yes) or 0 (No)]	10,00	Yes	No	Yes	No
TYPE OF SERVICE	30,00	3.1	Passengers: Urban services	Range [1 (Yes) or 0 (No)]	16,67	Yes	Yes	Yes	Yes
		3.2	Passengers: Conventional services	Range [1 (Yes) or 0 (No)]	16,67	Yes	Yes	Yes	Yes
		3.3	Passengers: High speed services	Range [1 (Yes) or 0 (No)]	16,67	Yes	Yes	Yes	Yes
		3.4	Freight: Conventional services	Range [1 (Yes) or 0 (No)]	16,67	No	No	Yes	Yes
		3.5	Freight: Local applications	Range [1 (Yes) or 0 (No)]	16,67	No	Yes	Yes	Yes
		3.6	Both passengers and freight traffic	Range [1 (Yes) or 0 (No)]	16,67	No	Yes	Yes	Yes
TYPE OF VEHICLE	10,00	4.1	Fixed trainsets	Range [1 (Yes) or 0 (No)]	50,00	Yes	Yes	Yes	Yes
		4.2	Pods	Range [1 (Yes) or 0 (No)]	50,00	Yes	Yes	Yes	No

Multi-Criteria-Analysis (MCA)

- All three use cases have big potential for use in today's rail infrastructure in contrast to the pure maglev systems.
- Most notably are the
 - High interoperability
 - Low impact on existing infrastructure
 - High adaptability and scalability

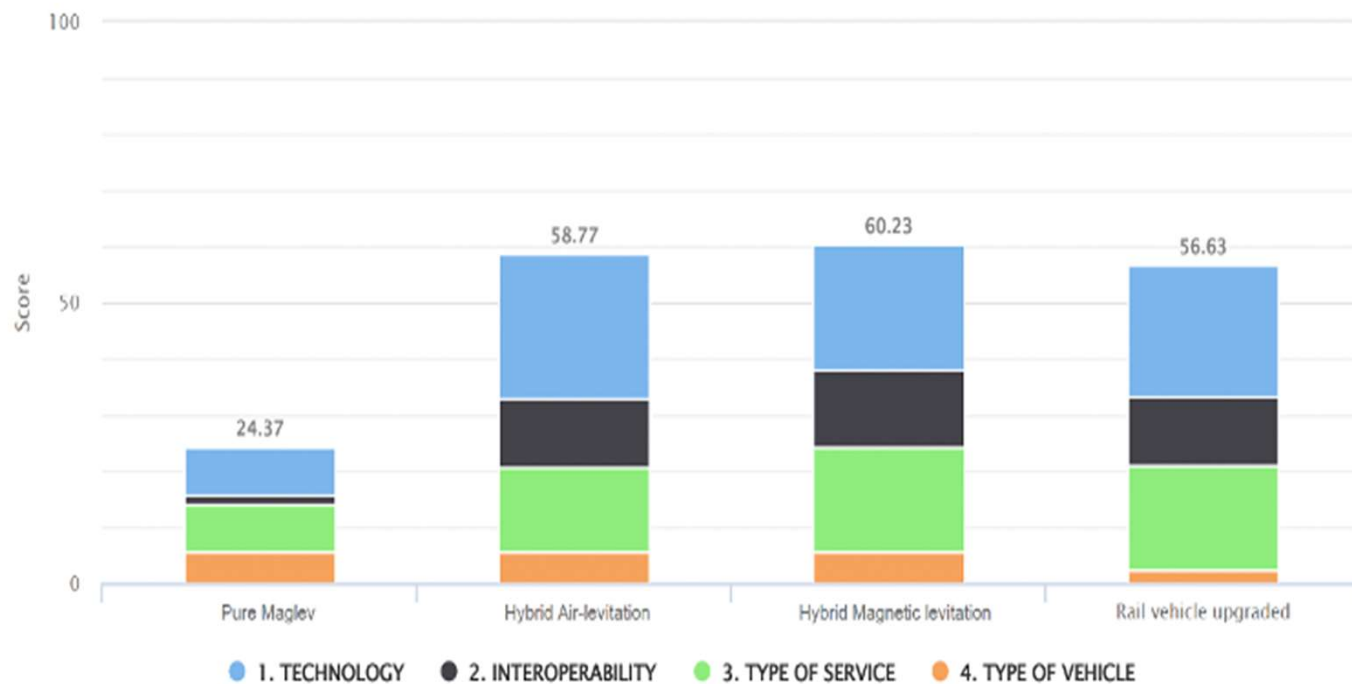

Results

The primary commercial benefits of adopting new MDS technologies:

1. Concentrate technology-intensive devices on limited track stretches
2. Achieve improved longitudinal accelerations (i.e. quicker acceleration and braking)
3. Sustain higher lateral acceleration, leading this way to higher speed on curves

- Benefit 1 is particularly relevant for the incline pusher
- Benefits 2 and 3 are most significant for levitation MDS

	Freight application	Passenger application
Hybrid MDS based on air levitation	Local freight applications (Medium-term)	Conventional passenger services (Long-term)
Hybrid MDS based on magnetic levitation	Conventional freight services (Long-term)	High speed passenger services (Long-term)
Rail vehicle upgraded	Local freight applications (Short-term)	Conventional passenger services (Medium-term)

Figure 6. Selection of possible use cases for MDS applications.

Conclusion

The MCA shows in detail that all the three approaches have significant benefits:

- The “conventional railway upgraded” is well-suited as an overlay on a regular rail system to increase performance and sustainability.
- The two levitation use cases are delivering performance benefits.
- All use cases keep interoperability with the existing rail system and allow mixed operation.
- Strategic niches for implementation are easier to find with MDS.



MaDe4Rail
FA7

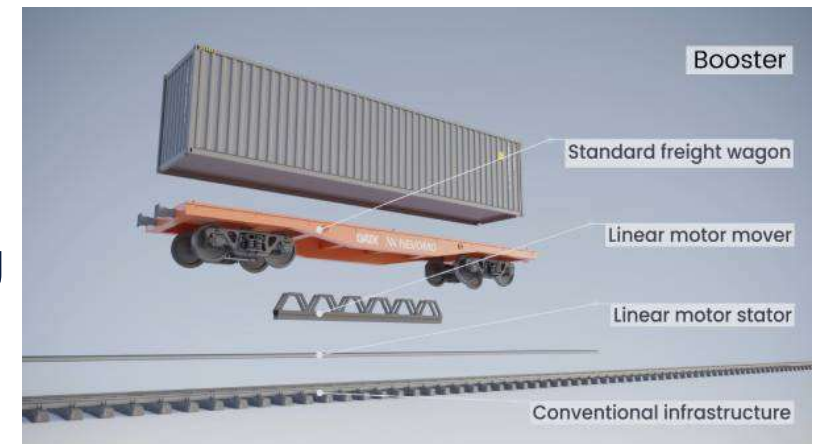

Principle of updated conventional freight wagon (source: NEVOMO)

Even more

- [MaDe4Rail Final Event](#)
- **Date:** 25 September 2024
- **Location:** Berlin, Germany
- InnoTrans from 14:00 CET to 18:00 CET in hall 6.3, room A.

TRACK A

TOPIC - MAGLEV TECHNOLOGICAL RESEARCH AND DEVELOPMENT

Friday 2024-09-20

A 3: Linear Motors and A 5: Reliability, Safety and Operational Control

Malmö Live Room 5

Chair: TBD

Time	Titel	Presenter
11:10 - 11:30	A 3 Potential benefits of linear motor based traction boosters for reducing track construction costs in conventional railways	William Liu

TRACK B

TOPIC - MAGLEV PROJECTS AND IMPLEMENTATIONS

Friday 2024-09-20

Malmö Live Room 6

Chair: Prof. Dr. Johannes Kluehspies

Time	Titel	Presenter
10:00 10:20	B 1 Applications of Maglev Derived Systems into European interoperable railway network: compatibility challenges, required interfaces, potential benefits*	Stefano Ricci

Thank you for your attention & interest!

Proceedings of Maglev 2024

Reference Number of Abstract/Full Paper here 7814-A-2466

Improved Railway Performance by Maglev Derived Systems

Technological readiness and operational concepts in specific use cases of Maglev Derived Systems to improve railway performance

Michael Meyer zu Hörste, DLR, Braunschweig, Germany, Michael.meyerzuoerste@dlr.de

Jesus Felez, UPM, Madrid, Spain.

Benedikt Scheier, DLR, Braunschweig, Germany, benedikt.scheier@dlr.de

Michael Schultz-Wildelau, NEVOMO, Frankfurt, Germany. **Lorenzo Andrea Parrotta**, Ironbox Srl, Spresiano (TV), Italy. **Luca Cesaretti**, Ironbox Srl, Spresiano (TV), Italy. **Giuseppe Carcasi**, RFI, Rome, Italy.

Angela Nocita, RFI, Rome, Italy. **Camilo Patiño Puerta**, RFI, Rome, Italy. **Marjorie De Belen**, RFI, Rome, Italy. **Giovanni De Blasio**, RFI, Rome, Italy.

William Liu, KTH Royal Institute of Technology, Stockholm, Sweden. **Carlos Casanueva**, KTH Royal Institute of Technology, Stockholm, Sweden.

Join [#MaDe4Rail](#) on LinkedIn



Co-funded by the European Union

The results described here are part of the project MaDe4Rail, which is partially funded by the European Commission through the Europe's Rail Joint Undertaking under the Horizon Europe Programme with the grant agreement no 101121851. Views and opinions expressed are however those of the author(s) only and do not necessarily reflect those of the European Union or Europe's Rail. Neither the European Union nor Europe's Rail can be held responsible for them.

REFERENCES

- [1] MaDe4Rail D2.1, 2024. Functional, technical, operational and economical overview of conventional rail systems, traditional maglev systems and innovative maglev-derived systems.
https://www.rfi.it/content/dam/rfi/innovazione-etecnologie/progetti/horizon/deliverables/MaDe4Rail_Deliverable_D2.1.zip
- [2] MaDe4Rail D6.1, 2024. Technology Readiness Assessment of Maglev-derived systems.
https://www.rfi.it/content/dam/rfi/innovazione-etecnologie/progetti/horizon/deliverables/MaDe4Rail_Deliverable_D6.1.pdf
- [3] Brans, J.-P., Mareschal, B., 2005. Promethee Methods, in: Multiple Criteria Decision Analysis: State of the Art Surveys. Springer-Verlag, New York, pp. 163–186.
https://doi.org/10.1007/0-387-23081-5_5
- [4] Ferreira H., Stephan R. Air Cushion Vehicle (ACV): History Development and Maglev Comparison // Transportation Systems and Technology. - 2019. - Vol. 5. - N. 1. - P. 5-25. doi: [10.17816/transsyst2019515-25](https://doi.org/10.17816/transsyst2019515-25)
- [5] MaDe4Rail D2.2, 2024. Potential benefits to the railway system derived from maglev and maglev-derived systems.
https://www.rfi.it/content/dam/rfi/innovazione-etecnologie/progetti/horizon/deliverables/MaDe4Rail_Deliverable_D2.2.pdf