

A Collaborative Engineering Framework To Accelerate The Design Of Novel Aircraft Configurations

Research Gap

Need for a methodology to improve collaboration between discipline specialists to automate and accelerate the design process by digitizing it.

Solution: Collaborative Engineering Framework (CPACS ↔ MDAX ↔ RCE)

Digitization and standardization enable the creation of an integrated design process that can significantly reduce integration problems and has the potential to greatly accelerate the exploration of the design space.

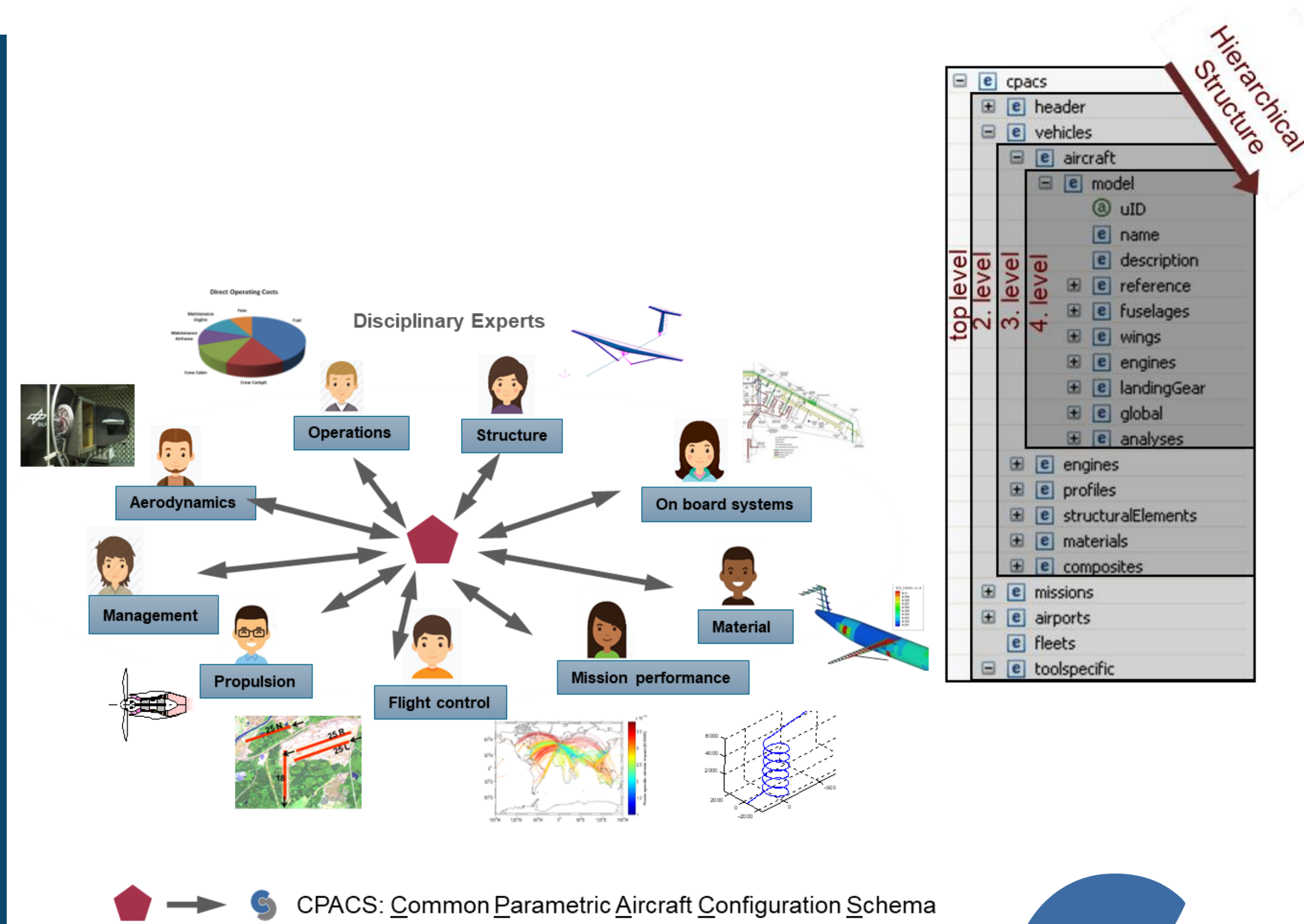

CPACS data exchange model

For more than two decades, the Common Parametric Aircraft Configuration Schema (CPACS) has supported collaborative aircraft design. During this time, CPACS has been continuously enhanced to meet changing design requirements. With the recent interest of the aviation community in alternative **propulsion** and **on-board system** architectures, such as hybrid electric propulsion concepts, the need for an integrated system definition within the CPACS data schema becomes apparent. As part of the recent CPACS 3.5 release, the **system definition** developed in the EXACT project aims for a flexible system definition to enable a multidisciplinary and multifidelity application. It allows the explicit definition of aircraft systems and facilitates the aircraft design process between system experts and overall aircraft designers.

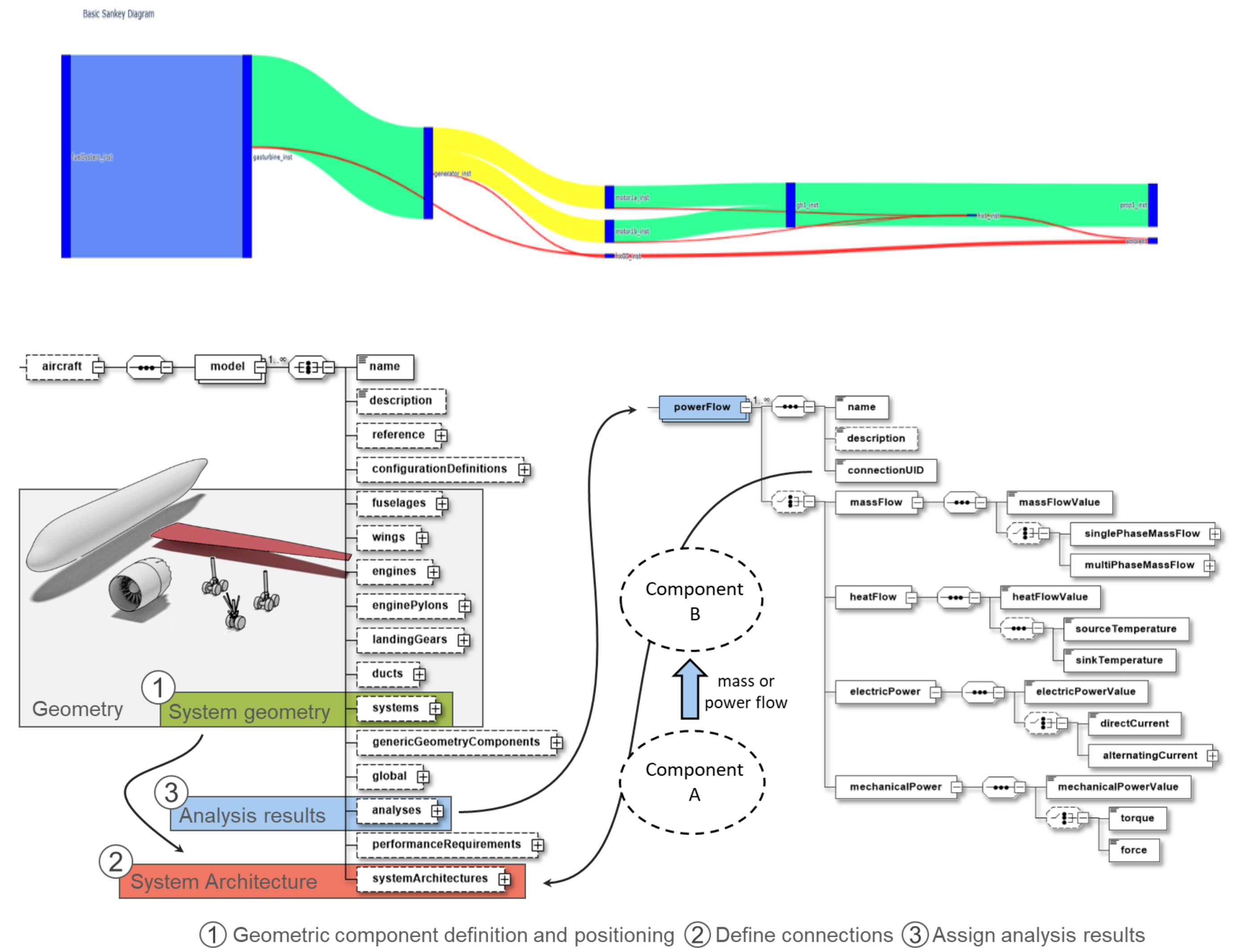
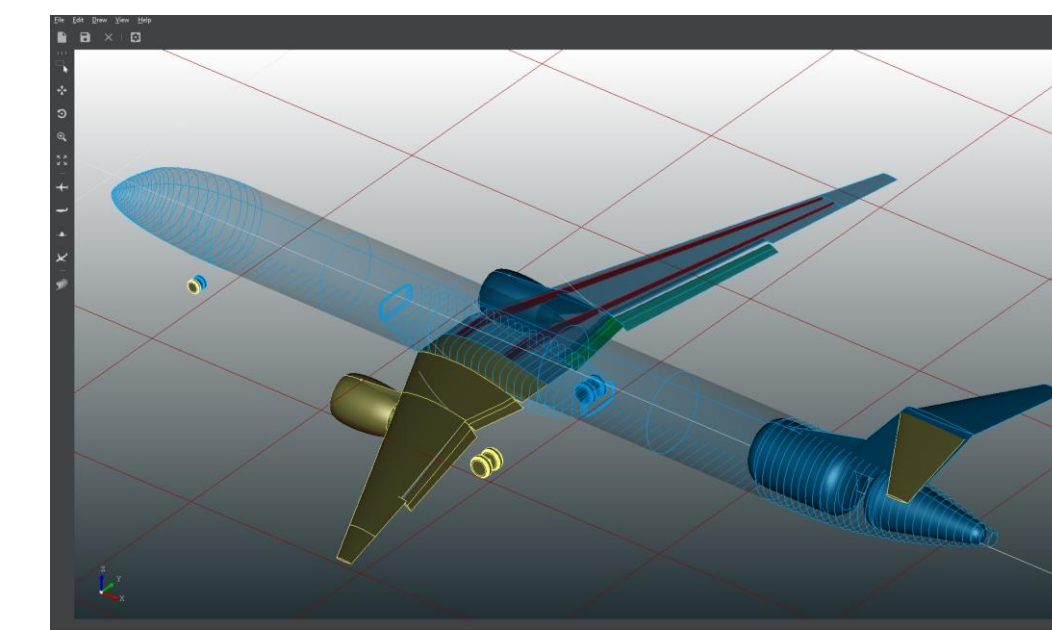

More Info: Marko Alder, Erwin Moerland, Jonas Jepsen, and Björn Nagel. Recent advances in establishing a common language for aircraft design with CPACS. In Aerospace Europe Conference, 2020

Collaborative simulation based on loosely-coupled, multidisciplinary workflows

Collaborative simulation workflows are designed and executed to investigate solutions to regional and short-range air transportation demand in an environmentally and economically sustainable manner by exploring the design space and evaluating a wide range of configurations and interesting concepts.

The platform used is the in-house developed Remote Component Environment (RCE), which in combination with a **server network** allows the disciplinary experts to share their competencies as engineering services, while maintaining control over proprietary software.

The generated results are then stored in a formal and **centralized storage** location, from where they can be retrieved and inspected by all project participants.

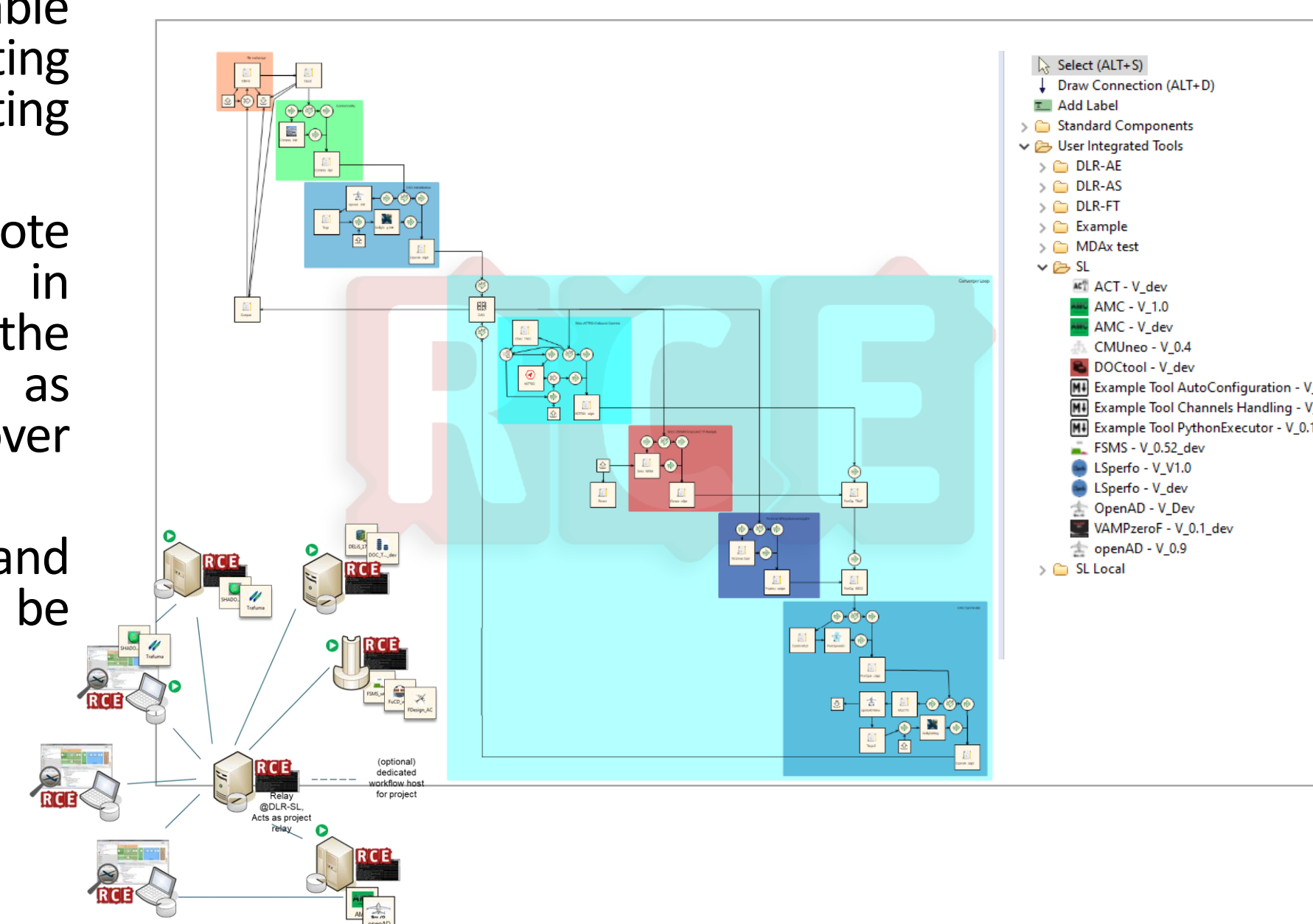
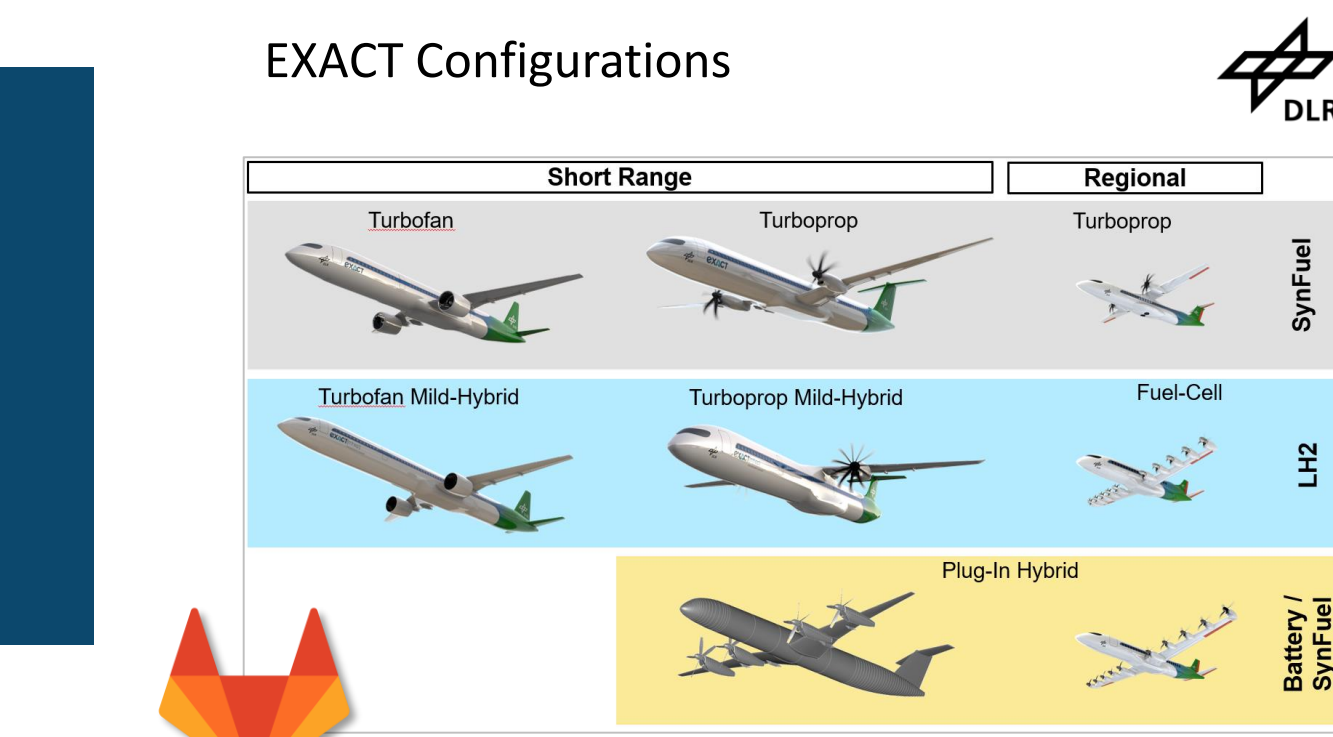

More info: Brigitte Boden, Jan Flink, Niklas Först, Robert Mischke, Kathrin Schaffert, Alexander Weinert, Annika Wohlan, and Andreas Schreiber. RCE: An integration environment for engineering and science. SoftwareX, 2021



- Easy-to-use interface for defining Input and Output of available models
- Intuitive and responsive XDSM-based user interface
- Data connection inspection and editing
- Continuous feedback on workflow status
- RCE** One-click export to RCE

MDAX Workflow Modeler

The design of a complex product like an aircraft involves different disciplines, technical or otherwise, working in conjunction with one another. Integration of such disciplines, their interaction with each other, and the exchange of diverse data-sets leads to time- and resource-intensive workflow development process.

A **collaborative Multidisciplinary Design Optimization (MDO)** workflow designing platform, developed in-house, called MDO Workflow Design Accelerator (MDAX), is used to make the process easier and faster. MDAX uses the extended Design Structure Matrix (XDSM) representation to describe the workflows and provides additional operations resulting in an executable workflow which can be exported to process integration platforms like RCE, OpenMDAO etc. It provides efficient methods to inspect and explore the different disciplinary components of the workflow and their data couplings.

The latest additions to the environment include automatic minimization of feedback, modelling sub-workflows as components, value-based identification of variables and discipline (de)activation.

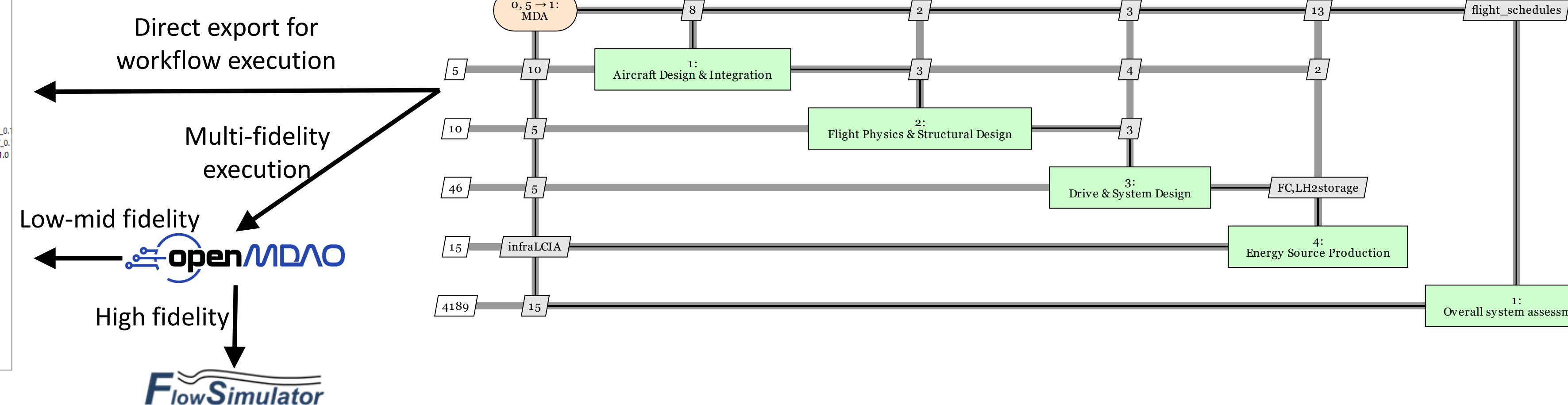

More info: Sparsh Garg, Jasper H. Bussemaker, Luca Boggiero, and Björn Nagel. MDAX: Enhancements In A Collaborative MDO Workflow Formulation Tool. AIAA Aviation, 2024