

## Workshop

AX- Process Simulation – From the current opportunities to a joint identification of future needs



Wissen für Morgen



# Where can simulations support along the process chain?

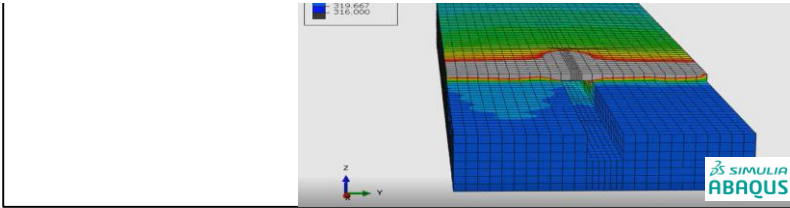
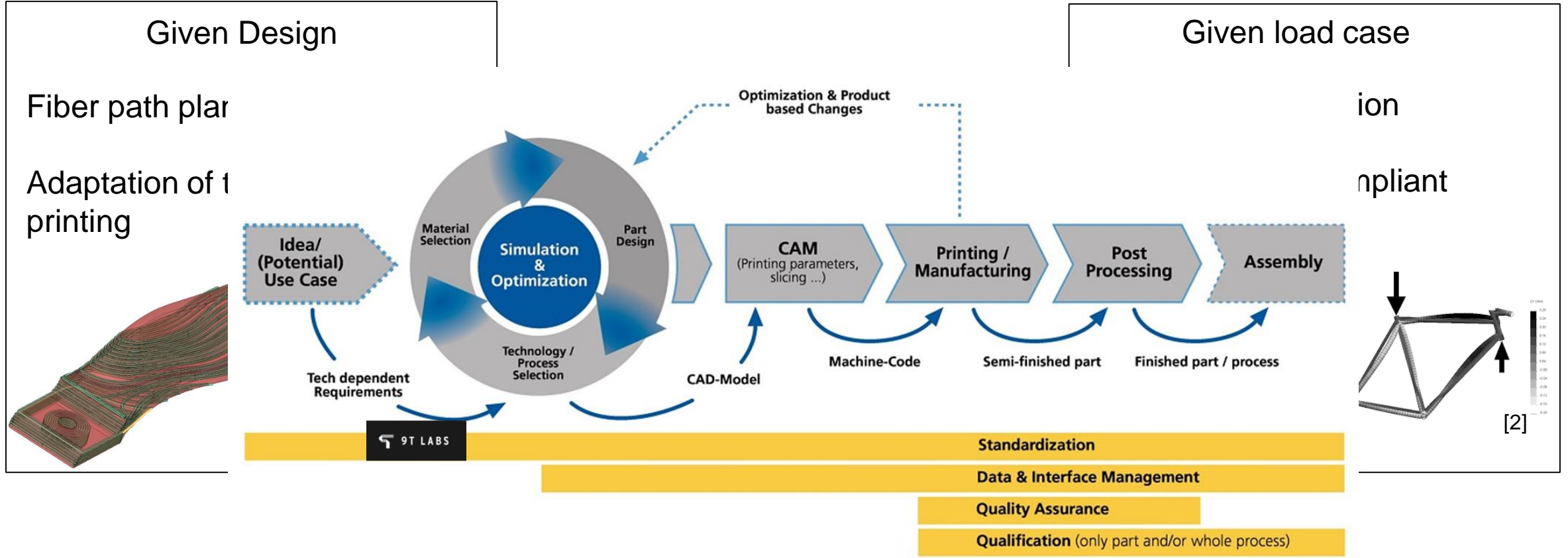

# Motivation

- Right choice of print parameters is the key for parts with suitable properties
- Optimization is often not possible through the many parameters and their interaction
- Process simulations can help to overcome key challenges in AX like Geometric conformity, Residual stress management etc.

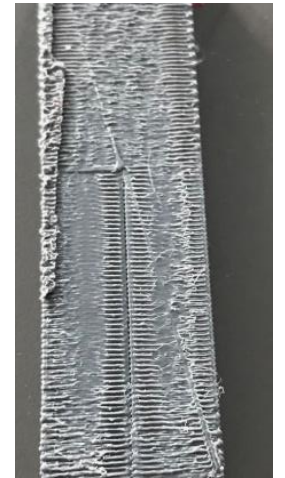
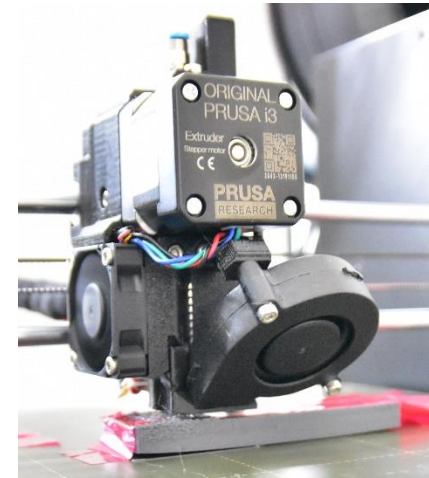

# Introduction

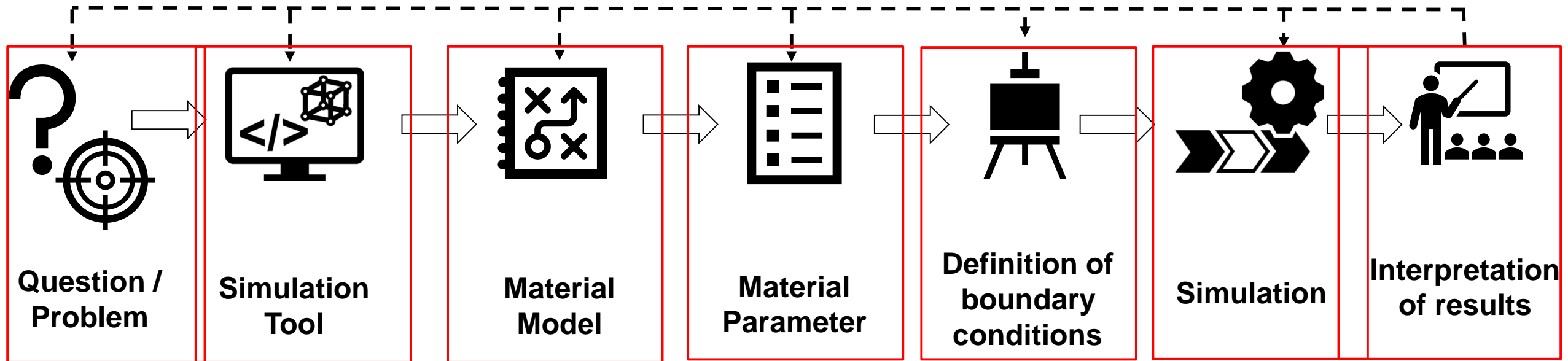

# Process simulation

- Available tool capabilities:
  - Temperature distribution
  - Residual stresses
  - Warpage

- Research:

- Bonding models
- Coupling with structure analysis
- Effects of Crystallization
- Dimensional accuracy
- Analysis of the process parameter - part properties relationship
- Prediction of complex geometries and the build part properties

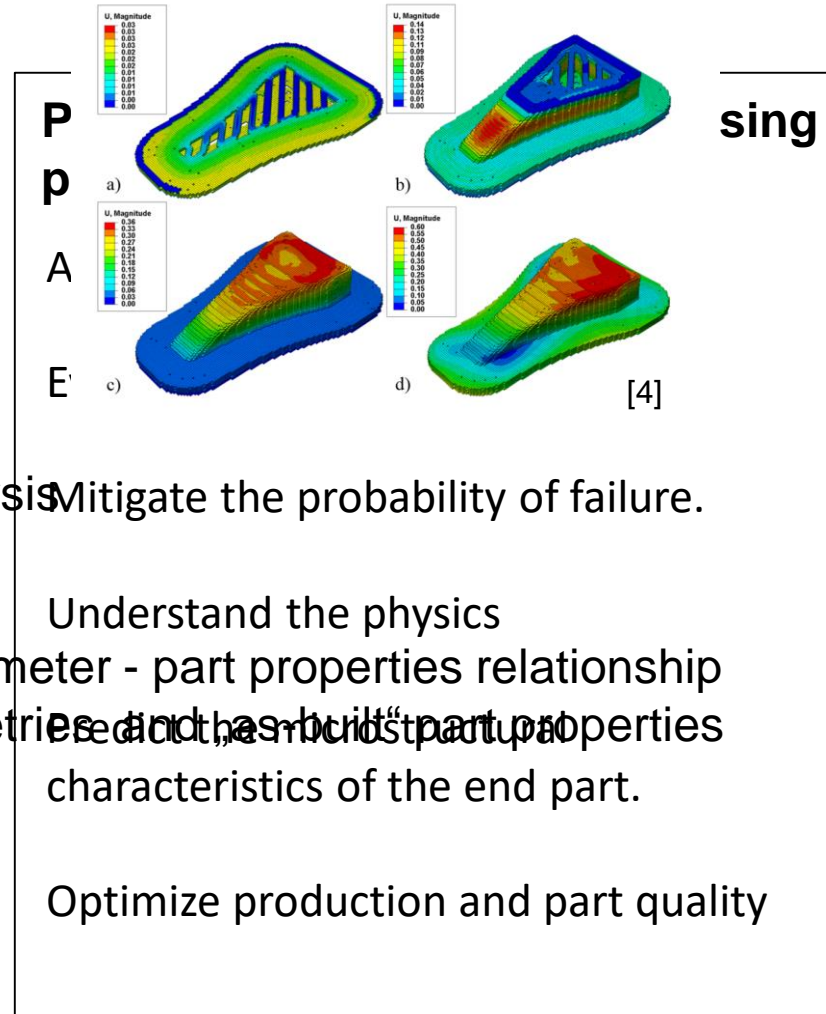

Mitigate the probability of failure.

Understand the physics

parameter - part properties relationship

and the build part properties

characteristics of the end part.

Optimize production and part quality



# Process simulations on different scales

- Influence of process parameters on material properties can be analysed on different scales

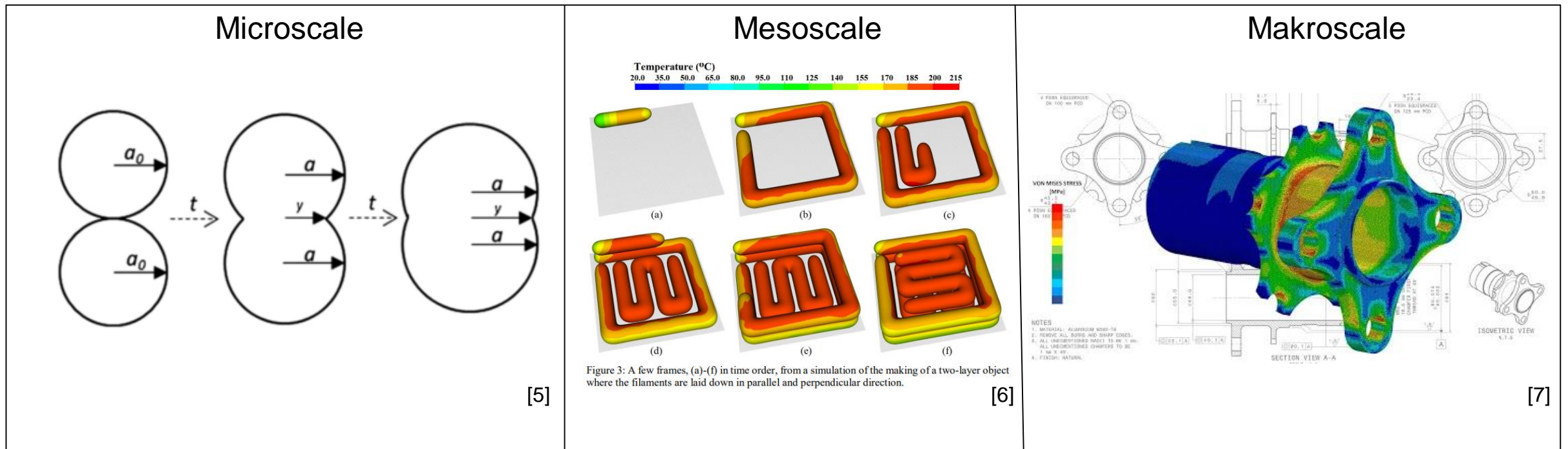

## Example of a process simulation – drone rotor blade

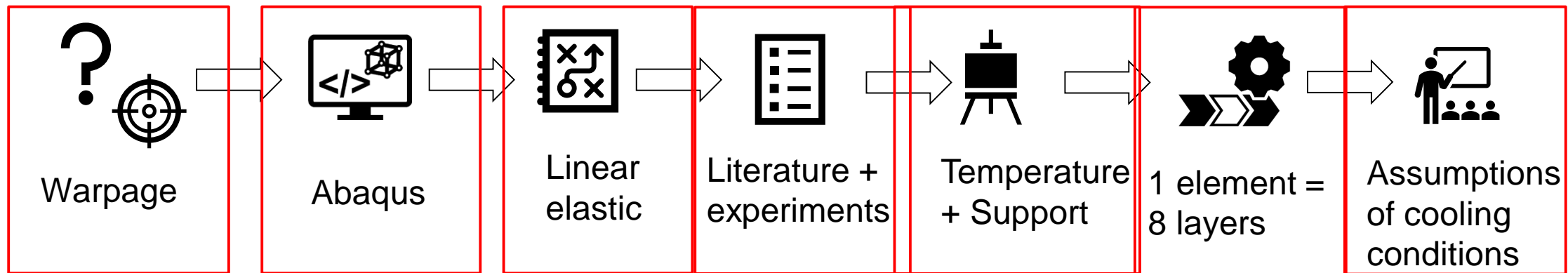
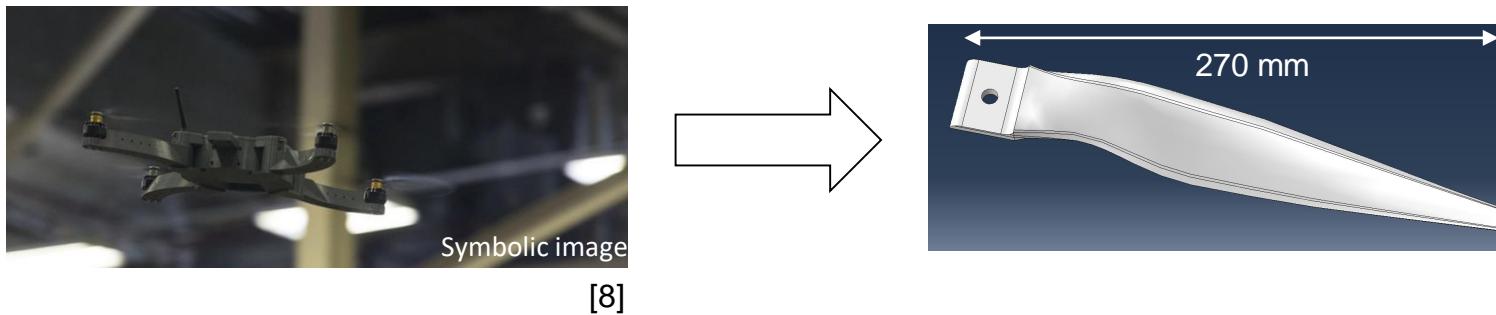

# FDM process simulation – Basic concept

CAD

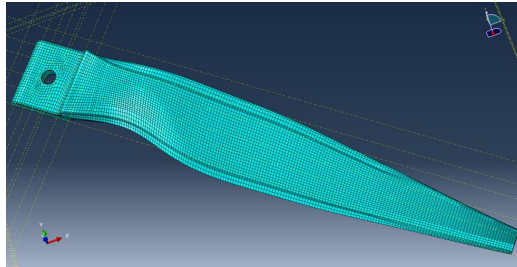

ToolPath  
Conversation  
G-Code->EventSeries

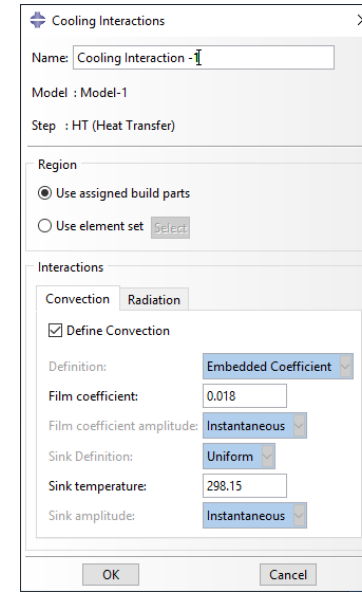

Analysis

Meshing

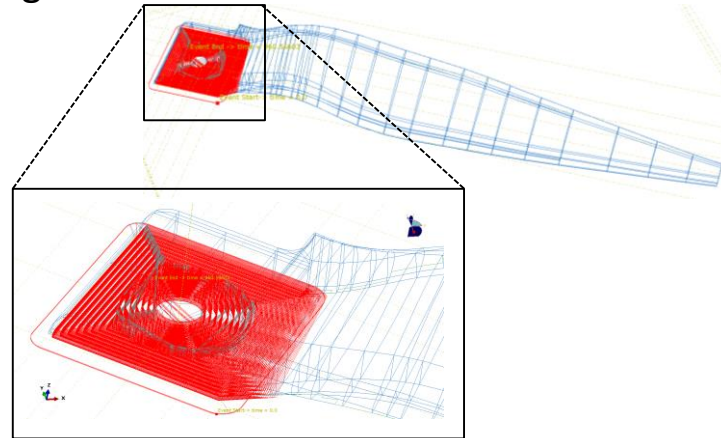

Thermal boundary  
conditions

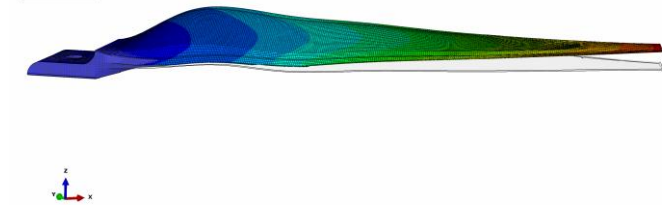
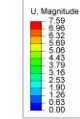

# Example of a process simulation – drone rotor blade



Symbolic image

[8]

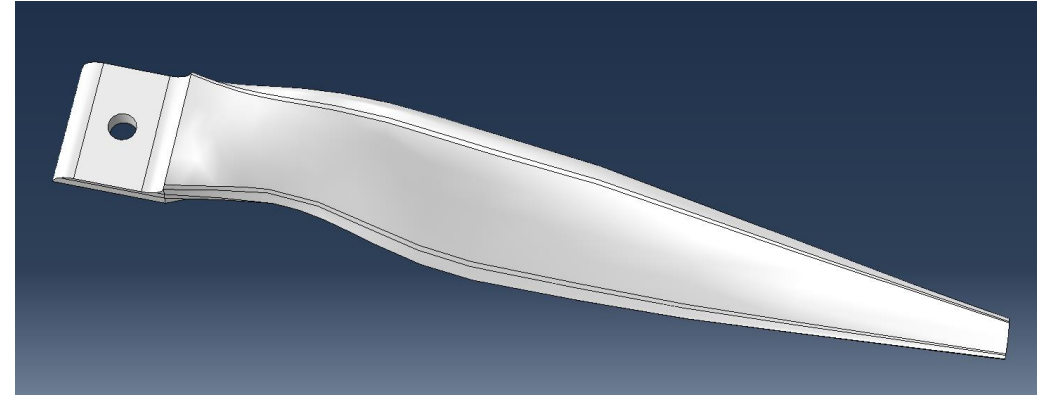
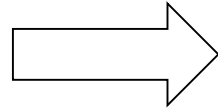

[9]

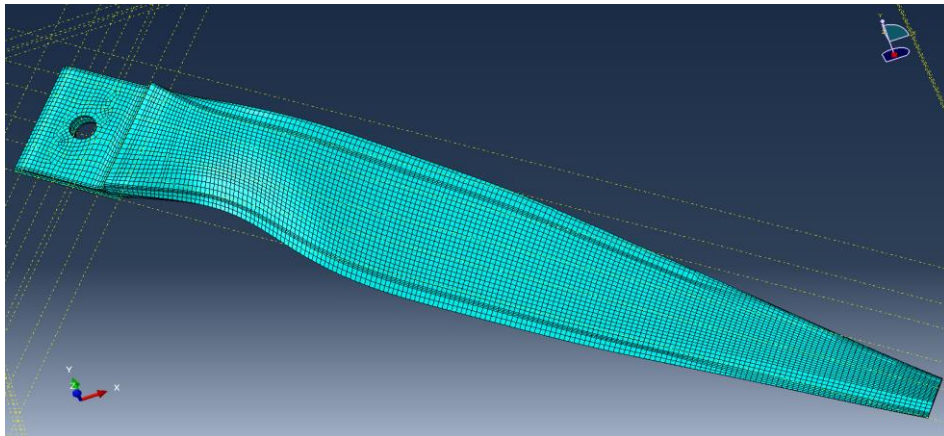
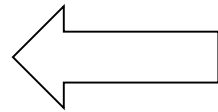
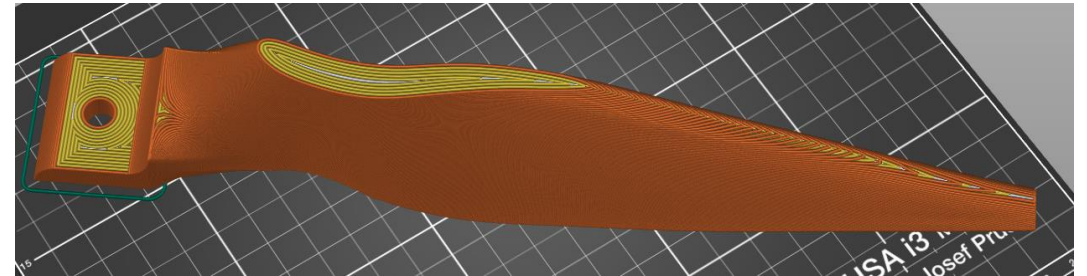
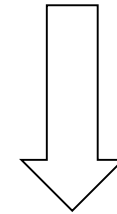

# Example of a process simulation – Process simulation temperature

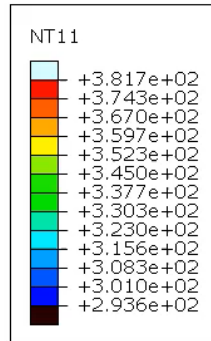

Step: Step-1 Frame: 0  
Total Time: 0.000000

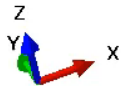

# Example of a process simulation – Process simulation material orientation



Step: Step-1 Frame: 0  
Total Time: 0.000000

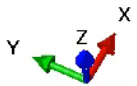

# Example of a process simulation – Temperature analysis

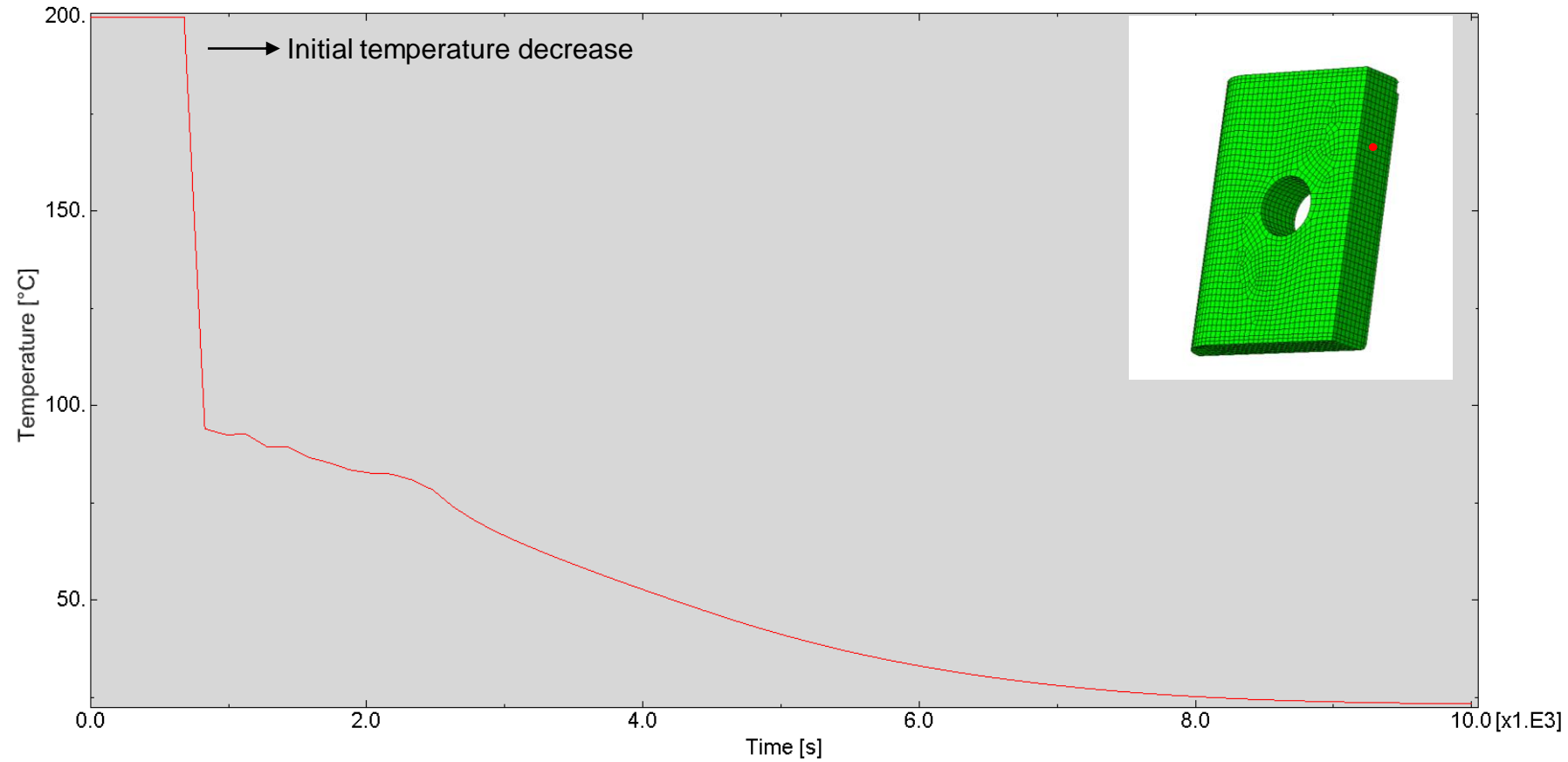

# Example of a process simulation – Warpage analysis

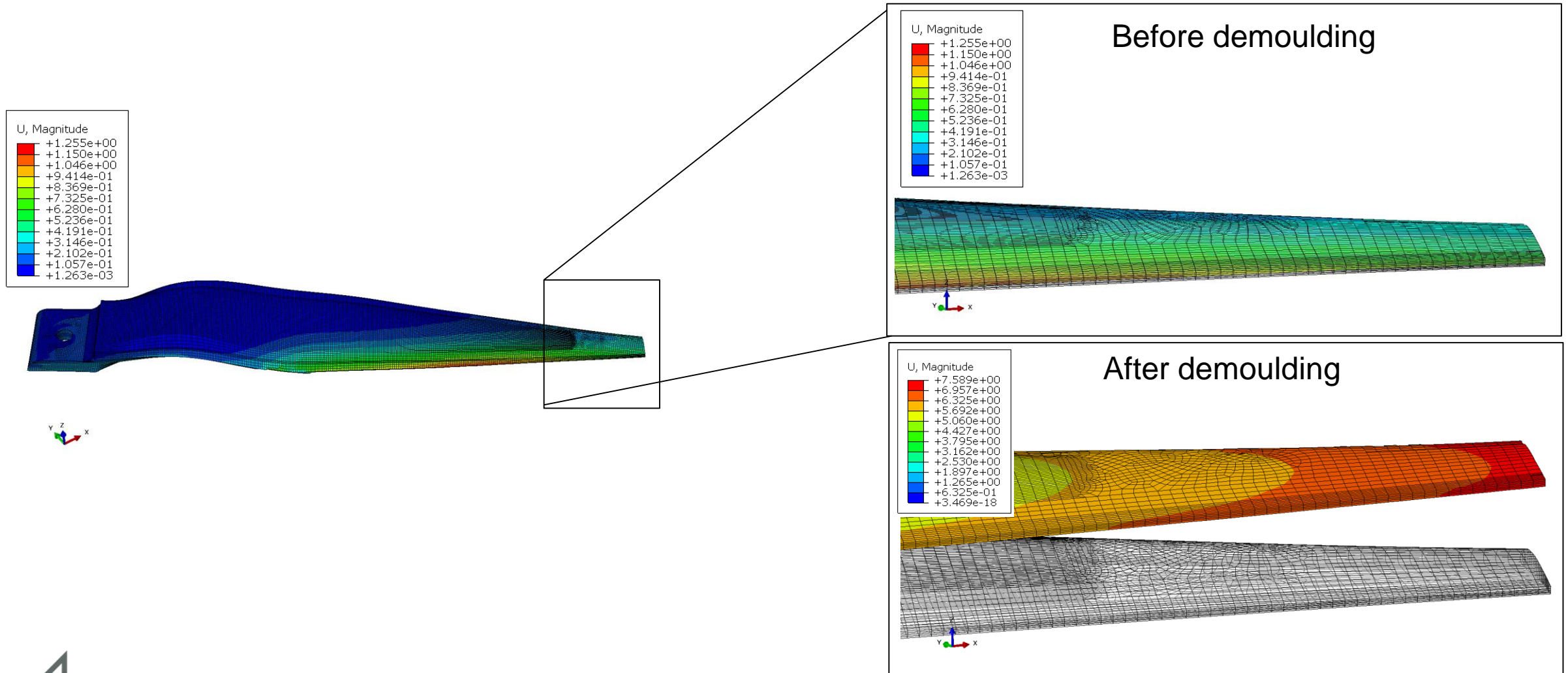

# Workshop overview

## Workshop part 1 (20 min.)

- 1a: Warm up
- 1b: Workshop
  - What are the main obstacles for the implementation of (process) simulations in current workflows?
  - In your opinion, for which of your key challenges can process simulation provide support?
  - In your opinion and for your application: Where do you see the highest benefit of the process simulation?

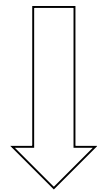

Identify current and future needs for simulation tools

## Workshop part 2 (10 min.)

- Where do you see Empower AX?
- Future Workshops



# References

- [1] [https://paulino.ce.gatech.edu/active\\_research.html](https://paulino.ce.gatech.edu/active_research.html)
- [2] [https://www.researchgate.net/publication/273531612\\_Parametric\\_Finite\\_Element\\_Analysis\\_of\\_Bicycle\\_Frame\\_Geometries/fulltext/5552aa6308ae6943a86d86f5/Parametric-Finite-Element-Analysis-of-Bicycle-Frame-Geometries.pdf](https://www.researchgate.net/publication/273531612_Parametric_Finite_Element_Analysis_of_Bicycle_Frame_Geometries/fulltext/5552aa6308ae6943a86d86f5/Parametric-Finite-Element-Analysis-of-Bicycle-Frame-Geometries.pdf)
- [3] Ponche et al.: „A novel methodology of design for Additive Manufacturing applied to Additive Laser Manufacturing process”, Robotics and Computer-Integrated Manufacturing, Volume 30, Issue 4, August 2014, Pages 389-398
- [4] Brenken, B: „Extrusion Deposition Additive Manufacturing of Fiber Reinforced Semi-Crystalline Polymers”, 2017
- [5] Coogan, T. J. , Kazmer D.: “Modeling of interlayer contact and contact pressure during fused filament fabrication”, Journal of Rheology 63, 655 (2019)
- [6] Xia et al.: „Fully Resolved Numerical Simulations of Fused Deposition Modeling. Part I—Fluid Flow”, Rapid Prototyping Journal, Volume 24, Issue 2, 2018
- [7] <https://blog.spatial.com/additive-manufacturing-process>
- [8] <https://www.3dnatives.com/de/3d-druck-drohnen-140720161/#!>
- [9] DLR project Urban rescue

