

RAW
Internet-Draft
Intended status: Informational
Expires: 8 May 2020

N. Maeurer, Ed.
T. Graeupl, Ed.
German Aerospace Center (DLR)
C. Schmitt, Ed.
Research Institute CODE, UniBwM
5 November 2019

L-band Digital Aeronautical Communications System (LDACS)
draft-maeurer-raw-ldacs-00

Abstract

This document provides an overview of the architecture of the L-band Digital Aeronautical Communications System (LDACS), which provides a secure, scalable and spectrum efficient terrestrial data link for civil aviation. LDACS is a scheduled, reliable multi-application cellular broadband system with support for IPv6.

Status of This Memo

This Internet-Draft is submitted in full conformance with the provisions of [BCP 78](#) and [BCP 79](#).

Internet-Drafts are working documents of the Internet Engineering Task Force (IETF). Note that other groups may also distribute working documents as Internet-Drafts. The list of current Internet-Drafts is at <https://datatracker.ietf.org/drafts/current/>.

Internet-Drafts are draft documents valid for a maximum of six months and may be updated, replaced, or obsoleted by other documents at any time. It is inappropriate to use Internet-Drafts as reference material or to cite them other than as "work in progress."

This Internet-Draft will expire on 8 May 2020.

Copyright Notice

Copyright (c) 2019 IETF Trust and the persons identified as the document authors. All rights reserved.

This document is subject to [BCP 78](#) and the IETF Trust's Legal Provisions Relating to IETF Documents (<https://trustee.ietf.org/license-info>) in effect on the date of publication of this document. Please review these documents carefully, as they describe your rights and restrictions with respect to this document. Code Components extracted from this document must include Simplified BSD License text

as described in Section 4.e of the [Trust Legal Provisions](#) and are provided without warranty as described in the Simplified BSD License.

Table of Contents

1.	Introduction	3
2.	Terminology	3
2.1.	Terms used in this document	3
3.	Motivation and Use Cases	4
3.1.	Voice Communications Today	5
3.2.	Data Communications Today	5
4.	Provenance and Documents	6
5.	Characteristics	7
5.1.	LDACS Physical Layer	7
5.2.	LDACS Data Link Layer	8
5.3.	LDACS Data Rates	8
5.4.	Reliability and Availability	8
5.4.1.	LDACS Medium Access	8
5.4.2.	LDACS Resource Allocation	9
5.4.3.	LDACS Handovers	9
6.	Architecture	10
6.1.	Protocol Stack	10
6.1.1.	Medium Access Control (MAC) Entity Services	12
6.1.2.	Data Link Service (DLS) Entity Services	13
6.1.3.	Voice Interface (VI) Services	13
6.1.4.	Link Management Entity (LME) Services	13
6.1.5.	Sub-Network Protocol (SNP) Services	13
6.2.	LDACS Logical Communication Channels	14
6.3.	LDASC Framing Structure	15
6.3.1.	Forward Link	15
6.3.2.	Reverse Link	15
7.	Security Considerations	16
8.	Privacy Considerations	17
9.	IANA Considerations	17
10.	Acknowledgements	17
11.	Normative References	17
12.	Informative References	17
	Authors' Addresses	19

1. Introduction

One of the main pillars of the modern Air Traffic Management (ATM) system is the existence of a communication infrastructure that enables efficient aircraft guidance and safe separation in all phases of flight. Current systems are technically mature but suffering from the VHF band's increasing saturation in high-density areas and the limitations posed by analogue radio. Therefore, aviation globally and the European Union (EU) in particular, strives for a sustainable modernization of the aeronautical communication infrastructure.

In the long-term, ATM communication shall transition from analogue VHF voice and VDL2 communication to more spectrum efficient digital data communication. The European ATM Master Plan foresees this transition to be realized for terrestrial communications by the development and implementation of the L-band Digital Aeronautical Communications System (LDACS). LDACS shall enable IPv6 based air-ground communication related to the safety and regularity of the flight. The particular challenge is that no new frequencies can be made available for terrestrial aeronautical communication. It was thus necessary to develop procedures to enable the operation of LDACS in parallel with other services in the same frequency band.

2. Terminology

2.1. Terms used in this document

The following terms are used in the context of DetNet in this document:

A/A Air-To-Air
AeroMACS Aeronautical Mobile Airport Communication System
A/G Air-To-Ground
AM(R)S Aeronautical Mobile (Route) Service
ANSP Air traffic Network Service Provider
AOC Aeronautical Operational Control
AS Aircraft Station
ATC Air-Traffic Control
ATM Air-Traffic Management
ATN Aeronautical Telecommunication Network
ATS Air Traffic Service
CCCH Common Control Channel
DCCH Dedicated Control Channel
DCH Data Channel
DLL Data Link Layer
DLS Data Link Service
DME Distance Measuring Equipment
DSB-AM Double Side-Band Amplitude Modulation

FAA Federal Aviation Administration
FCI Future Communication Infrastructure
FDD Frequency Division Duplex
FL Forward Link
GANP Global Air Navigation Plan
GNSS Global Navigation Satellite System
GS Ground Station
GSC Ground-Station Controller
HF High Frequency
ICAO International Civil Aviation Organization
IWF Interworking Function
kbit/s kilobit per second
LDACS L-band Digital Aeronautical Communications System
LLC Logical Link Layer
LME LDACS Management Entity
MAC Medium Access Layer
MF Multi Frame
MIMO Multiple Input Multiple Output
OFDM Orthogonal Frequency-Division Multiplexing
OFDMA Orthogonal Frequency-Division Multiplexing Access
PDU Protocol Data Units
PHY Physical Layer
QoS Quality of Service
RL Reverse Link
SARPs Standards And Recommended Practices
SESAR Single European Sky ATM Research
SF Super-Frame
SNP Sub-Network Protocol
SSB-AM Single Side-Band Amplitude Modulation
SNDCF Sub-Network Dependent Convergence Function
TBO Trajectory-Based Operations
TDM Time Division Multiplexing
TDMA Time-Division Multiplexing-Access
VDL2 VHF Data Link mode 2
VHF Very High Frequency
VI Voice Interface

3. Motivation and Use Cases

Aircraft are currently connected to Air-Traffic Control (ATC) and Airline Operational Control (AOC) via voice and data communications systems through all phases of a flight. Within the airport terminal, connectivity is focused on high bandwidth communications, while during en-route high reliability, robustness, and range is the main focus. Voice communications may use the same or different equipment as data communications systems. In the following the main differences between voice and data communications capabilities are

summarized. The assumed use cases for LDACS completes the list of use cases stated in [RAW-USE-CASES] and the list of reliable and available wireless technologies presented in [RAW-TECHNOS].

3.1. Voice Communications Today

Voice links are used for Air-To-Ground (A/G) and Air-To-Air (A/A) communications. The communication equipment is either ground-based working in the High Frequency (HF) or Very High Frequency (VHF) frequency band or satellite-based. All voice communications is operated via open broadcast channels without any authentication, encryption or other protective measures. The use of well-proven communication procedures via broadcast channels helps to enhance the safety of communications by taking into account that other users may encounter communication problems and may be supported, if required. The main voice communications media is still the analogue VHF Double Side-Band Amplitude Modulation (DSB-AM) communications technique, supplemented by HF Single Side-Band Amplitude Modulation (SSB-AM) and satellite communications for remote and oceanic areas. DSB-AM has been in use since 1948, works reliably and safely, and uses low-cost communication equipment. These are the main reasons why VHF DSB-AM communications is still in use, and it is likely that this technology will remain in service for many more years. This however results in current operational limitations and becomes impediments in deploying new Air-Traffic Management (ATM) applications, such as flight-centric operation with point-to-point communications.

3.2. Data Communications Today

Like for voice, data communications into the cockpit is currently provided by ground-based equipment operating either on HF or VHF radio bands or by legacy satellite systems. All these communication systems are using narrowband radio channels with a data throughput capacity of some kilobits per second. While the aircraft is on ground some additional communications systems are available, like Aeronautical Mobile Airport Communication System (AeroMACS), operating in the Airport (APT) domain and able to deliver broadband communication capability.

The data communication networks used for the transmission of data relating to the safety and regularity of the flight must be strictly isolated from those providing entertainment services to passengers. This leads to a situation that the flight crews are supported by narrowband services during flight while passengers have access to inflight broadband services. The current HF and VHF data links cannot provide broadband services now or in the future, due to the lack of available spectrum. This technical shortcoming is becoming a

limitation to enhanced ATM operations, such as Trajectory-Based Operations (TBO) and 4D trajectory negotiations.

Satellite-based communications are currently under investigation and enhanced capabilities are under development which will be able to provide inflight broadband services and communications supporting the safety and regularity of the flight. In parallel, the ground-based broadband data link technology LDACS is being standardized by ICAO and has recently shown its maturity during flight tests [SCH191]. The LDACS technology is scalable, secure and spectrum efficient and provides significant advantages to the users and service providers. It is expected that both - satellite systems and LDACS - will be deployed to support the future aeronautical communication needs as envisaged by the ICAO Global Air Navigation Plan (GANP).

4. Provenance and Documents

The development of LDACS has already made substantial progress in the Single European Sky ATM Research (SESAR) framework, and is currently being continued in the follow-up program, SESAR2020 [RIH18]. A key objective of the SESAR activities is to develop, implement and validate a modern aeronautical data link able to evolve with aviation needs over long-term. To this end, an LDACS specification has been produced [GRA19] and is continuously updated; transmitter demonstrators were developed to test the spectrum compatibility of LDACS with legacy systems operating in the L-band [SAJ14]; and the overall system performance was analyzed by computer simulations, indicating that LDACS can fulfil the identified requirements [GRA11].

LDACS standardization within the framework of the ICAO started in December 2016. The ICAO standardization group has produced an initial Standards and Recommended Practices (SARPs) document [ICAO18]. The SARPs document defines the general characteristics of LDACS. The ICAO standardization group plans to produce an ICAO technical manual - the ICAO equivalent to a technical standard - within the next years. Generally, the group is open to input from all sources and develops LDACS in the open.

Up to now the LDACS standardization has been focused on the development of the physical layer and the data link layer, only recently have higher layers come into the focus of the LDACS development activities. There is currently no "IPv6 over LDACS" specification; however, SESAR2020 has started the testing of IPv6-based LDACS testbeds. The IPv6 architecture for the aeronautical telecommunication network is called the Future Communications Infrastructure (FCI). FCI shall support quality of service, diversity, and mobility under the umbrella of the "multi-link concept". This work is conducted by ICAO working group WG-I.

In addition to standardization activities several industrial LDACS prototypes have been built. One set of LDACS prototypes has been evaluated in flight trials confirming the theoretical results predicting the system performance [GRA18] [SCH191].

5. Characteristics

LDACS will become one of several wireless access networks connecting aircraft to the Aeronautical Telecommunications Network (ATN). Access to the ATN is handled by the Ground-Station Controller (GSC), while several Ground-Stations (GS) are connected to one GSC. Thus the LDACS access network contains several GS, each of them providing one LDACS radio cell. LDACS can be therefore considered a cellular data link with a star-topology connecting Aircraft-Stations (AS) to GS with a full duplex radio link. Each GS is the centralized instance controlling all A/G communications within its radio cell. A GS supports up to 512 aircraft. All of this is depicted in Figure 1.

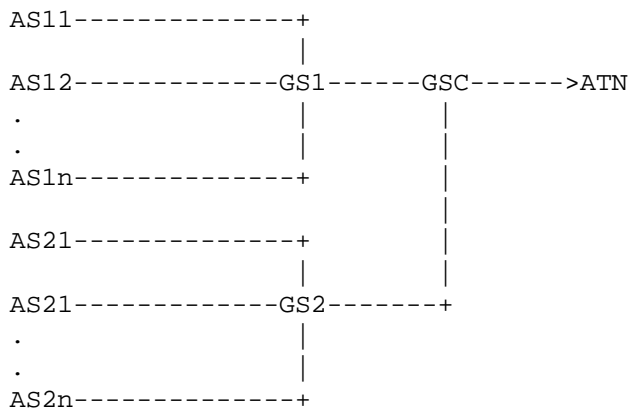

Figure 1: LDACS wireless topology

The LDACS air interface protocol stack defines two layers, the physical layer and the data link layer.

5.1. LDACS Physical Layer

The physical layer provides the means to transfer data over the radio channel. The LDACS GS supports bi-directional links to multiple aircraft under its control. The forward link direction (FL; ground-to-air) and the reverse link direction (RL; air-to-ground) are separated by frequency division duplex. Forward link and reverse link use a 500 kHz channel each. The ground-station transmits a

continuous stream of Orthogonal Frequency-Division Multiplexing (OFDM) symbols on the forward link. In the reverse link different aircraft are separated in time and frequency using a combination of Orthogonal Frequency-Division Multiple-Access (OFDMA) and Time-Division Multiple-Access (TDMA). Aircraft thus transmit discontinuously on the reverse link with radio bursts sent in precisely defined transmission opportunities allocated by the ground-station. LDACS does not support beam-forming or Multiple Input Multiple Output (MIMO) [SCH192].

5.2. LDACS Data Link Layer

The data-link layer provides the necessary protocols to facilitate concurrent and reliable data transfer for multiple users. The LDACS data link layer is organized in two sub-layers: The medium access sub-layer and the logical link control sub-layer. The medium access sub-layer manages the organization of transmission opportunities in slots of time and frequency. The logical link control sub-layer provides acknowledged point-to-point logical channels between the aircraft and the ground-station using an automatic repeat request protocol. LDACS supports also unacknowledged point-to-point channels and ground-to-air broadcast.

5.3. LDACS Data Rates

The user data rate of LDACS is 315 kbit/s to 1428 kbit/s on the forward link, and 294 kbit/s to 1390 kbit/s on the reverse link, depending on coding and modulation. Due to strong interference from legacy systems in the L-band, the most robust coding and modulation should be expected for initial deployment i.e. 315/294 kbit/s on the forward/reverse link, respectively.

5.4. Reliability and Availability

LDACS has been designed with applications related to the safety and regularity of the flight in mind. It has therefore been designed as a deterministic wireless data link (as far as possible).

5.4.1. LDACS Medium Access

LDACS medium access is always under the control of the ground-station of a radio cell. Any medium access for the transmission of user data has to be requested with a resource request message stating the requested amount of resources and class of service. The ground-station performs resource scheduling on the basis of these requests and grants resources with resource allocation messages. Resource request and allocation messages are exchanged over dedicated contention-free control channels.

5.4.2. LDACS Resource Allocation

LDACS has two mechanisms to request resources from the scheduler in the ground-station. Resources can either be requested "on demand" with a given class of service. On the forward link, this is done locally in the ground-station, on the reverse link a dedicated contention-free control channel is used called Dedicated Control Channel (DCCH); roughly 83 bit every 60 ms). A resource allocation is always announced in the control channel of the forward link (Common Control Channel (CCCH); variable sized). Due to the spacing of the reverse link control channels of every 60 ms, a medium access delay in the same order of magnitude is to be expected.

Resources can also be requested "permanently". The permanent resource request mechanism supports requesting recurring resources in given time intervals. A permanent resource request has to be canceled by the user (or by the ground-station, which is always in control). User data transmissions over LDACS are therefore always scheduled by the ground-station, while control data uses statically (i.e. at net entry) allocated recurring resources (DCCH and CCCH). The current specification documents specify no scheduling algorithm. However performance evaluations so far have used strict priority scheduling and round robin for equal priorities for simplicity. In the current prototype implementations LDACS classes of service are thus realized as priorities of medium access and not as flows. Note that this can starve out low priority flows. However, this is not seen as a big problem since safety related message always go first in any case. Scheduling of reverse link resources is done in physical Protocol Data Units (PDU) of 112 bit (or larger if more aggressive coding and modulation is used). Scheduling on the forward link is done Byte-wise since the forward link is transmitted continuously by the ground-station.

5.4.3. LDACS Handovers

In order to support diversity, LDACS supports handovers to other ground-stations on different channels. Handovers may be initiated by the aircraft (break-before-make) or by the ground-station (make-before-break) if it is connected to an alternative ground-station via the same ground-station controller. Beyond this, FCI diversity shall be implemented by the multi-link concept.

6. Architecture

Aircraft-Station (AS), Ground-Station (GS) and Ground-Station Controller (GSC) form the basic LDACS network. 512 aircraft can be served by one GS where the GS sends a continuous data stream in the Forward Link (FL) to the AS. The Reverse Link (RL) consists of individual bursts of data from each AS to GS. This means, for every RL communication the AS first needs to request the respective resource allocation within its cell from the GS before being able to send. Both FL and RL communication, including user and control data, is done via the air gap over the radio link between AS and GS. On the ground a GSC is responsible for serving several GSs on the control plane, forming an LDACS sub-network with its LDACS internal control plane infrastructure. The GSs are linked to an access router in the user plane, which in turn is linked to an Air/Ground router, being now the direct connection to the ground network. The ATN is used for example by Air traffic Network Services Providers (ANSP) and airlines to exchange Air Traffic Service (ATS) or Airline Operational Control (AOC) data between the ground infrastructure and the aircraft. Figure 2 provides a more detailed overview.

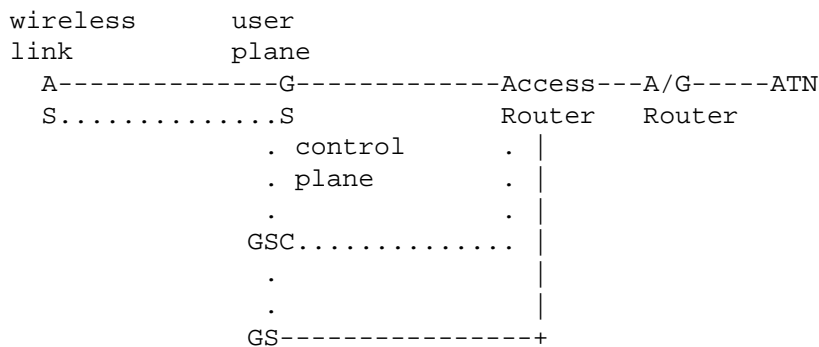

Figure 2: LDACS sub-network with two GSs

6.1. Protocol Stack

The protocol stack of LDACS is implemented in the AS and GS as follows: It consists of the Physical Layer (PHY) with five major functional blocks above it. Four are placed in the Data Link Layer (DLL) of the AS and GS: (1) Medium Access Layer (MAC), (2) Voice Interface (VI), (3) Data Link Service (DLS), (4) LDACS Management Entity (LME). The last entity resides within the sub-network layer: Sub-Network Protocol (SNP).

The LDACS network is externally connected to voice units, radio control units, and the ATN network layer through a Sub-Network Dependent Convergence Function (SNDCF; OSI network layers), Convergence Sub-layer, or Interworking Function (IWF; legacy networks) not discussed here.

The SNP connects the AS and GS DLL providing end-to-end user plane connectivity between the LDACS AS and GS.

The DLL provides Quality of Service (QoS) assurance. Multiplexing of different service classes is possible. Except for the initial aircraft cell-entry and a Type 1 handover, which is not discussed here, medium access is deterministic, with predictable performance. Optional support for adaptive coding and modulation is provided as well. The four functional blocks of the LDACS DLL are organised into two sub-layers, the MAC sub-layer and the Logical Link Control (LLC) sub-layer discussed in the next sections. [GRA19].

Figure 3 shows the protocol stack of LDACS as implemented in the AS and GS.

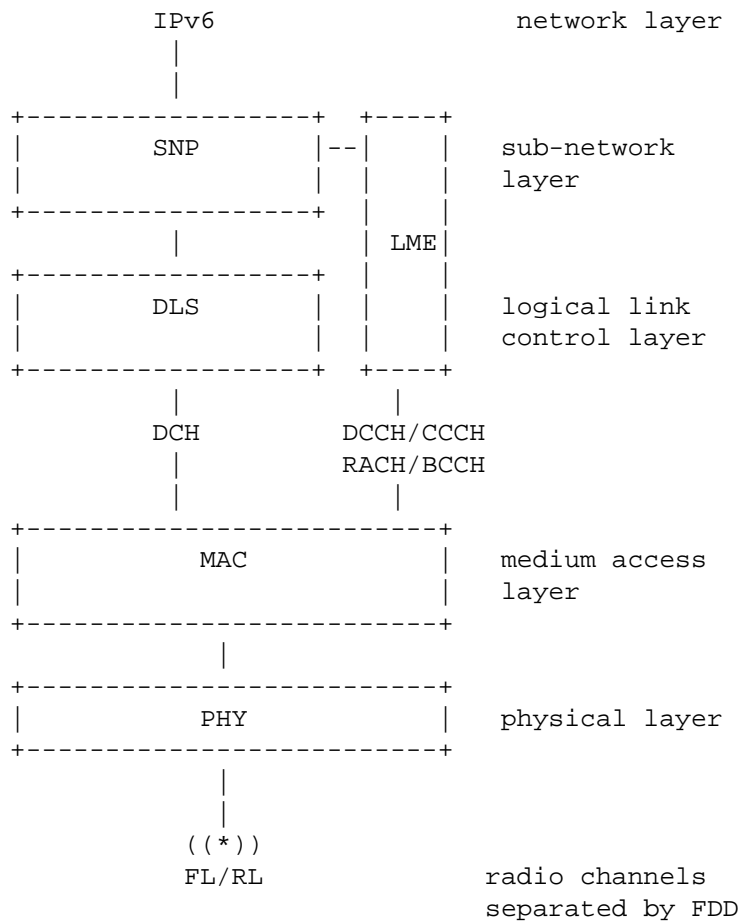

Figure 3: LDACS protocol stack

6.1.1. Medium Access Control (MAC) Entity Services

Time Framing Service: The MAC time framing service provides the frame structure necessary to realise slot-based Time Division Multiplex (TDM) access on the physical link. It provides the functions for the synchronisation of the MAC framing structure and the PHY layer framing. The MAC time framing provides a dedicated time slot for each logical channel. [GRA19]

Medium Access Service: The MAC sub-layer offers access to the physical channel to its service users. Channel access is provided through transparent logical channels. The MAC sub-layer maps logical channels onto the appropriate slots and manages the access to these

channels. Logical channels are used as interface between the MAC and LLC sub-layers. [GRA19]

6.1.2. Data Link Service (DLS) Entity Services

The DLS provides acknowledged and unacknowledged (including broadcast and packet mode voice) bi-directional exchange of user data. If user data is transmitted using the acknowledged data link service, the sending DLS entity will wait for an acknowledgement from the receiver. If no acknowledgement is received within a specified time frame, the sender may automatically try to retransmit its data. However, after a certain number of failed retries, the sender will suspend further retransmission attempts and inform its client of the failure. [GRA19]

6.1.3. Voice Interface (VI) Services

The VI provides support for virtual voice circuits. Voice circuits may either be set-up permanently by the GS (e.g. to emulate voice party line) or may be created on demand. The creation and selection of voice circuits is performed in the LME. The VI provides only the transmission services. [GRA19]

6.1.4. Link Management Entity (LME) Services

Mobility Management Service: The mobility management service provides support for registration and de-registration (cell entry and cell exit), scanning RF channels of neighbouring cells and handover between cells. In addition, it manages the addressing of aircraft/ASs within cells. It is controlled by the network management service in the GSC. [GRA19]

Resource Management Service: The resource management service provides link maintenance (power, frequency and time adjustments), support for adaptive coding and modulation (ACM), and resource allocation. [GRA19]

6.1.5. Sub-Network Protocol (SNP) Services

Data Link Service: The data link service provides functions required for the transfer of user plane data and control plane data over the LDACS sub-network. [GRA19]

Security Service: The security service shall provide functions for secure communication over the LDACS sub-network. Note that the SNP security service applies cryptographic measures as configured by the ground station controller. [GRA19]

6.2. LDACS Logical Communication Channels

Data Link Service: The data link service provides functions required for the transfer of user plane data and control plane data over the LDACS sub-network. [GRA19]

In order to communicate, LDACS uses several logical channels in the MAC layer [GRA19]:

1. The GS announces its existence and several necessary physical parameters in the Broadcast Channel (BCCH) to incoming AS.
2. The Random Access Channel (RACH) enables the AS to request access to an LDACS cell.
3. In the Forward Link (FL) the Common Control Channel (CCCH) is used by the GS to distribute and grant access to system resources.
4. The reverse direction is covered by the Reverse Link (RL), where aircraft need to request resources (in so called resource allocation) in order to be allowed to send. This happens via the Dedicated Common Control Channel (DCCH).
5. User data itself is communicated in the Data Channel (DCH) on the FL and RL.

Figure 4 shows in detail the distribution of each slot. The LDACS super-frame is repeated every 240 ms and carries all control plane and user plane logical channels in separate slots of variable length.

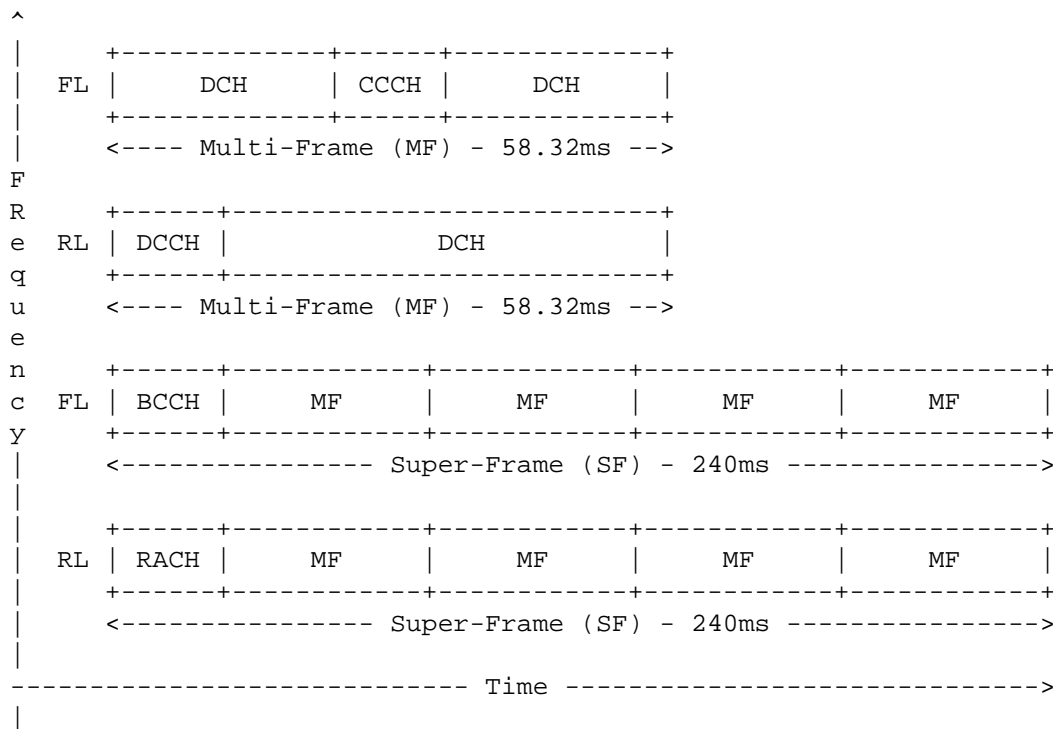

Figure 4: LDACS frame structure

6.3. LDASC Framing Structure

The LDACS framing structure for FL and RL is based on Super-Frames (SF) of 240 ms duration. Each SF corresponds to 2000 OFDM symbols. The FL and RL SF boundaries are aligned in time (from the view of the GS).

6.3.1. Forward Link

In the FL, an SF contains a Broadcast Frame of duration $T_{BC} = 6.72$ ms (56 OFDM symbols), and four Multi-Frames (MF), each of duration $T_{MF} = 58.32$ ms (486 OFDM symbols).

6.3.2. Reverse Link

In the RL, each SF starts with a Random Access (RA) message of length $T_{RA} = 6.72$ ms with two opportunities for sending reverse link random access frames, followed by four MFs. These MFs have the same fixed duration of $T_{MF} = 58.32$ ms as in the FL, but a different internal structure.

7. Security Considerations

Aviation will require secure exchanges of data and voice messages for managing the air-traffic flow safely through the airspaces all over the world. The main communication method for ATC today is still an open analogue voice broadcast within the aeronautical VHF band. Currently, the information security is purely procedural based by using well-trained personnel and proven communications procedures. This communication method has been in service since 1948. Future digital communications waveforms will need additional embedded security features to fulfil modern information security requirements like authentication and integrity. These security features require sufficient bandwidth which is beyond the capabilities of a VHF narrowband communications system. For voice and data communications, sufficient data throughput capability is needed to support the security functions while not degrading performance. LDACS is a mature data link technology with sufficient bandwidth to support security.

Security considerations for LDACS are the official ICAO SARPS [ICA018]:

1. LDACS shall provide a capability to protect the availability and continuity of the system.
2. LDACS shall provide a capability including cryptographic mechanisms to protect the integrity of messages in transit.
3. LDACS shall provide a capability to ensure the authenticity of messages in transit.
4. LDACS should provide a capability for nonrepudiation of origin for messages in transit.
5. LDACS should provide a capability to protect the confidentiality of messages in transit.
6. LDACS shall provide an authentication capability.
7. LDACS shall provide a capability to authorize the permitted actions of users of the system and to deny actions that are not explicitly authorized.
8. If LDACS provides interfaces to multiple domains, LDACS shall provide capability to prevent the propagation of intrusions within LDACS domains and towards external domains.

The cybersecurity architecture of LDACS [ICA018], [MAE18] and its extensions [MAE191], [MAE192] regard all of the aforementioned requirements, since LDACS has been mainly designed for air traffic management communication. Thus it supports mutual entity authentication, integrity and confidentiality capabilities of user data messages and some control channel protection capabilities [MAE192].

More details can be found here [MAE18], [MAE192] and [ICAO18].

From the very beginning of the development process security for LDACS has been addressed by design and thus meets the security objectives as standardized by ICAO [ICAO18].

8. Privacy Considerations

LDACS provides a Quality of Service (QoS), and the generic considerations for such mechanisms apply.

9. IANA Considerations

This memo includes no request to IANA.

10. Acknowledgements

The authors want to thank all contributors to the development of LDACS. Further, thanks to SBA Research Vienna for fruitful discussions on aeronautical communications concerning security incentives for industry and potential economic spillovers.

11. Normative References

12. Informative References

- [MAE191] Maeurer, N., Graeupl, T., and C. Schmitt, "Evaluation of the LDACS Cybersecurity Implementation", IEEE 38th Digital Avionics Systems Conference (DACS), pp. 1-10, New York, NY, USA , November 2019.
- [MAE192] Maeurer, N. and C. Schmitt, "Towards Successful Realization of the LDACS Cybersecurity Architecture: An Updated Datalink Security Threat- and Risk Analysis", IEEE Integrated Communications, Navigation and Surveillance Conference (ICNS), pp. 1-13, New York, NY, USA , November 2019.
- [GRA19] Graeupl, T., Rihacek, C., and B. Haindl, "LDACS A/G Specification", German Aerospace Center (DLR), Germany, SESAR2020 PJ14-02-01 D3.3.010 , 2017.
- [MAE18] Maeurer, N. and A. Bilzhause, "A Cybersecurity Architecture for the L-band Digital Aeronautical Communications System (LDACS)", IEEE 37th Digital Avionics Systems Conference (DASC), pp. 1-10, New York, NY, USA , 2017.

- [GRA11] Graeupel, T. and M. Ehammer, "L-DACS1 Data Link Layer Evolution of ATN/IPS", 30th IEEE/AIAA Digital Avionics Systems Conference (DASC), pp. 1-28, New York, NY, USA , 2011.
- [GRA18] Graeupel, T., Schneckenburger, N., Jost, T., Schnell, M., Filip, A., Bellido-Manganell, M.A., Mielke, D.M., Maeurer, N., Kumar, R., Osechas, O., and G. Battista, "L-band Digital Aeronautical Communications System (LDACS) flight trials in the national German project MICONAV", Integrated Communications, Navigation, Surveillance Conference (ICNS), pp. 1-7, New York, NY, USA , 2018.
- [SCH191] Schnell, M., "DLR Tests Digital Communications Technologies Combined with Additional Navigation Functions for the First Time", November 2019.
- [SCH192] Schnell, M., "Update on LDACS - The FCI Terrestrial Data Link", 19th Integrated Communications, Navigation and Surveillance Conference (ICNS), pp. 1-10, New York, NY, USA , November 2019.
- [ICAO18] International Civil Aviation Organization (ICAO), "L-Band Digital Aeronautical Communication System (LDACS)", International Standards and Recommended Practices Annex 10 - Aeronautical Telecommunications, Vol. III - Communication Systems , 2018.
- [SAJ14] Sajatovic, M., Guenzel, H., and S. Mueller, "WA04 D22 Test Report for Assessing LDACS1 Transmitter Impact upon DME/TACAN Receivers", 19th Integrated Communications, Navigation and Surveillance Conference (ICNS), pp. 1-10, New York, NY, USA , 2014.
- [RIH18] Rihacek, C., Haindl, B., Fantappie, P., Pierattelli, S., Graeupl, T., Schnell, M., and N. Fistas, "LDACS A/G Specification", Integrated Communications Navigation and Surveillance Conference (ICNS), pp. 1-8, New York, NY, USA , 2018.
- [RAW-TECHNOS] Thubert, P., Cavalcanti, D., Vilajosana, X., and C. Schmitt, "Reliable and Available Wireless Technologies", Work in Progress, Internet-Draft, [draft-thubert-raw-technologies-03](https://tools.ietf.org/html/draft-thubert-raw-technologies-03), 1 July 2019, <<https://tools.ietf.org/html/draft-thubert-raw-technologies-03>>.

[RAW-USE-CASES]

Papadopoulos, G., Thubert, P., Theoleyre, F., and C. Bernardos, "RAW use cases", Work in Progress, Internet-Draft, [draft-bernardos-raw-use-cases-00](https://tools.ietf.org/html/draft-bernardos-raw-use-cases-00), 5 July 2019, <<https://tools.ietf.org/html/draft-bernardos-raw-use-cases-00>>.

Authors' Addresses

Nils Maeurer (editor)
German Aerospace Center (DLR)
Muenchner Strasse 20
82234 Wessling
Germany

Email: Nils.Maeurer@dlr.de

Thomas Graeupl (editor)
German Aerospace Center (DLR)
Muenchner Strasse 20
82234 Wessling
Germany

Email: Thomas.Graeupl@dlr.de

Corinna Schmitt (editor)
Research Institute CODE, UniBwM
Werner-Heisenberg-Weg 28
85577 Neubiberg
Germany

Email: corinna.schmitt@unibw.de