

Availability of Maritime Radio Beacon Signals for R-Mode in the Southern Baltic Sea

S. Gewies, L. Grundhöfer & N. Hehenkamp
German Aerospace Center (DLR), Neustrelitz, Germany

ABSTRACT: This paper presents an overview of the development of a terrestrial positioning system called Ranging Mode (R-Mode) in the Southern Baltic Sea region which utilizes already existing maritime radio infrastructure. Here, an R-Mode testbed is planned to be set up until 2020 that meets maritime user needs for resilient PNT. First measurements of radio beacon signals on-board a vessel sailing in the Southern Baltic Sea show the good availability of beacon signals in this region. A comparison of received signals with a coverage prediction based on the nominal range of radio beacons shows the shortcoming of this approach and emphasizes the need for more elaborated coverage predictions which consider all effects of medium frequency wave propagation at day and night. In the measurements results the skywave has a major impact on the beacon signal stability in the night. The time stability of the signal amplitude seems to be a good indicator for disturbed reception conditions.

1 INTRODUCTION

Global Navigation Satellite Systems (GNSS), today the primary source for position, navigation and time (PNT) information for collision avoidance, navigation and communication systems on-board of a vessel, are highly vulnerable to unintentional and intentional interference, e.g. jamming and spoofing. A backup system is needed to overcome this threat and to enable new applications with an increased need for resilient PNT information.

Today only regional terrestrial navigation systems like eLORAN, LORAN-C or Chayka are available. An extension of them on a global scale is unlikely because important countries or regions like USA and Europe stopped the service a few years ago. Therefore, another system is needed.

One option is to use so called Signals of Opportunity (SoOP) broadcasted from existing

maritime radio infrastructure. Under considerations are the signals of maritime radio beacons and land based stations of the Automatic Identification System (AIS) (Oltmann & Hoppe 2008). Both have in common their good distribution of stations along the coastline near the main maritime traffic routes.

The ranging mode (R-Mode) system makes use of these SoOP. By transmitting synchronized ranging signals from modified maritime radio beacons (Johnson & Swaszek 2014a, Johnson et al. 2017) or AIS base stations (Johnson & Swaszek 2014b, Hu et al. 2015) it could be shown that range and position estimation with this approach is feasible.

It is generally assumed that the implementation of additional ranging signal components on the legacy SoOP is a cost effective way to setup a terrestrial navigation system. However, fundamental research, development, validation and standardization activities are necessary to establish R-Mode as a

recognized maritime backup system to GNSS (IALA 2016).

This paper presents the ongoing process of the implementation of an R-Mode testbed in the Baltic Sea and shows results of a signal strength measurement campaign in the destination area.

2 R-MODE TESTBED IN THE SOUTHERN BALTIC SEA

2.1 An area with high demand on resilient PNT

The Southern Baltic Sea is the region between Germany, Denmark, Sweden and Poland which exhibits a very high density of maritime traffic and on the other hand challenging conditions with respect to the risk of collisions and groundings. Tankers, container freighters and bulk carriers cross on their way along the main traffic route from east to west the way of ferries sailing from north to south. Furthermore, vessels have to stay in their lane to prevent collisions with oncoming vessels on the neighboring lane in traffic separation schemes. Additional static infrastructure such as wind farms reduces the maneuvering space nowadays and generates the need for new navigation applications.

The Baltic Sea is generally a shallow water. Especially the navigation in coastal areas, port approaches and ports requires high quality of navigational support (IMO 2002). To prevent any traffic disturbance and environmental harm for this ecological sensitive region resilient PNT information is necessary.

2.2 Precondition of the region

Maritime administrations around the Baltic Sea are aware of the challenges and implemented a dense network of maritime radio beacons to support differential GNSS (DGNSS) for accurate positioning (better than 10 m) with integrity and continuity for operation from coastal region to the berth (IALA 2015). Furthermore, a dense network of AIS base stations allows sea traffic monitoring along the coastline with a range of up to a few 10 kilometers and can support navigation by provision of safety relevant information from ashore.



Figure 1. Southern Baltic Sea surrounded by Poland, Germany, Denmark and Sweden. Radio beacons are indicated by dots and AIS base stations by triangles.

The operational DGNSS and AIS stations today are shown in Figure 1. Due to the different signal main propagation paths for the two systems, groundwave for DGNSS and line of sight for AIS, the range of the two station types differs and the AIS network is denser to compensate for its smaller station service area.

A precondition for the use of the SoOP for ranging and positioning is the visibility of the signals. For this reason the signal coverage was calculated based on the given nominal range of radio beacons which could be found on the IALA website, and for the AIS base stations the calculation considers the height of a base station antenna and a height of a ship antenna of 10 m above sea level. The predictions are shown in Figure 2 and Figure 3.

Obviously the density of available SoOP depends on the location in the Baltic Sea. The main east west traffic route, which is in the middle between the Swedish and German / Polish coast, is well covered with overlapping radio beacon service areas of these three countries and one Danish beacon. Instead the coastline especially at the border of Germany and Poland has highest density of AIS signals.

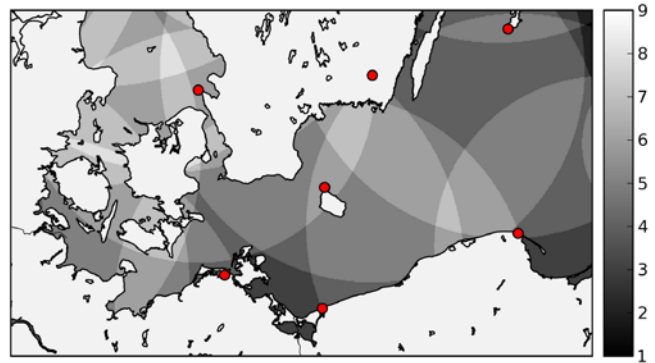

Figure 2. Number of available radio beacon signals calculated with nominal range of beacons.

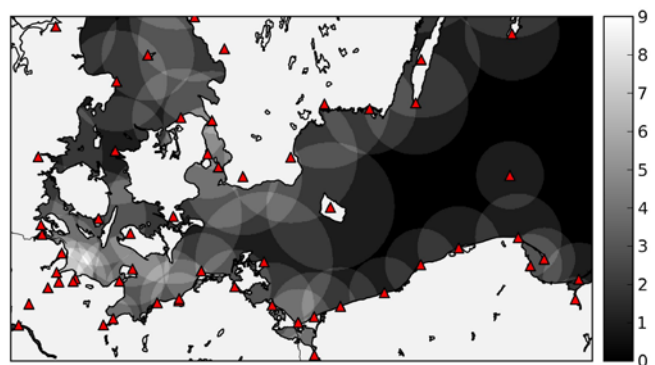

Figure 3. Number of available AIS base station signals calculated with base station antenna height.

Depending on the R-Mode positioning approach three or four SoOP have to be visible at the same time. This number could not be reached by just one SoOP in the entire Southern Baltic Sea. Both SoOP have to be analyzed in more detail. Therefore, the project R-Mode Baltic was initiated that will implement a testbed with both SoOP in the Baltic Sea.

2.3 Project R-Mode Baltic

Considering the results of former R-Mode activities which were summarized by Hoppe (Hoppe 2018), in 2017 a European research and development project of industry, national maritime administrations and research institutions was started. It has the goal to demonstrate that R-Mode is able to meet the maritime user PNT requirement for a backup system in the Southern Baltic Sea. An R-Mode testbed will be implemented until 2020 (Gewies et al. 2018).

The R-Mode technology is in an early development phase. First feasibility studies with different demonstrators are performed but it is still open which is the best way of implementing the ranging signal into the legacy signal of radio beacons and AIS base stations. The project team of R-Mode Baltic will investigate in

- R-Mode signal development for radio beacons which operate in the medium frequency (MF) band and reduction of main error sources,
- R-Mode signal development for AIS base stations which operate in the very high frequency (VHF) band,
- the analysis of the impact of different error components on the position,
- time synchronization methods for the R-Mode transmitter sites,
- the maritime user requirement.

Furthermore, the project team will develop R-Mode MF and VHF receivers and a VHF R-Mode transmitter. To show the benefit of having R-Mode signals available, an existing PNT data processing unit will be extended by additional R-Mode processing channels. This allows for automatically switching to R-Mode based positioning in case of unavailability of GNSS. A portable pilot unit will be adapted so that it continuously provides a position and warn the pilot about the reduced accuracy in case of showing an R-Mode based position.

The findings and developments of the project will be implemented in the R-Mode testbed. Up to six radio beacons and four AIS base stations will be upgraded so that they transmit synchronized R-Mode signals. An R-Mode receiver and a PNT data processing unit will be used for static and dynamic validation of R-Mode.

In the following the focus is on a specific part of R-Mode.

3 MF R-MODE

The MF R-Mode system uses maritime radio beacons as a source for SoOP. The radio beacons operate in Europe in the maritime band between 283.5 kHz and 315 kHz. Here, each radio beacon uses a channel of 500 Hz bandwidth and transmits data via MSK modulated RCTM messages with a data rate of 100 or 200 bits per second.

To enable ranging using the MF signal, two continuous wave (CW) signals are added to the transmission, one 225 Hz below and one 225 Hz above the carrier frequency. Thus, the original capability of legacy receivers to use the beacon is not

impeded since the MSK DGNSS messages can still be received.

Through phase estimation of each CW signal, the time of arrival (TOA) can be determined. Due to the relatively small wavelength of approximately 1 km in comparison with the intended transmission range of 300 km, ambiguities in the phase estimate have to be resolved. This can be achieved by using the beat frequency of both CW signals. On top of that, the MSK data transmissions can be used to assist ambiguity resolution and error correction.

The ranging through phase estimation requires a high time and oscillator stability as well as synchronization of all R-Mode transmitters to determine the TOA precisely. Thus, the transmitter hardware has to be updated by using a precise source of UTC.

The intended ranging accuracy of the R-Mode system lies below 10 m. To achieve that, various errors have to be mitigated.

Aside from the error introduced by clock instabilities, the largest source of error is caused by skywave propagation of the MF signal. The MF signal propagates both as groundwave and skywave which is reflected in a height of about 100 km at the E layer of the ionosphere. Since the skywave takes a different path on its way to the receiver it interferes with the groundwave with a different phase at the receiver antenna. This causes incorrect phase and thus distance estimation. The effect is especially present at night due to a weaker attenuation of the skywave by lower layers of the ionosphere. The mitigation of skywave interference is one of the main challenges on the way to the implementation of MF R-Mode.

4 RADIO BEACON SIGNAL AVAILABILITY IN THE SOUTHERN BALTIC SEA

A measurement campaign was performed to analyze the availability of SoOP in the Southern Baltic Sea. While sailing in the area between Poland, Germany, Denmark and Sweden, measurements of the field strength of all radio beacon signals in the maritime band reserved for the DGNSS service were conducted using the setup shown in Figure 4.

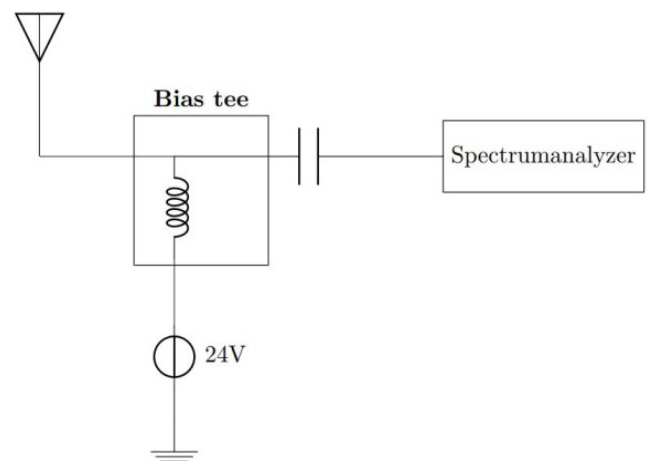

Figure 4. Used setup for field strength measurement.

For the measurements an R&S HE010E monitor antenna, which was fed with 24 V using a bias tee, and an R&S FS1000 spectrum analyzer were used. In order to enable a direct field strength measurement, corrections for the bias and a conversion factor (antenna factor) were stored in the FS1000. Each minute the GNSS position and a spectrum, which was calculated as the average over five spectra, were recorded. In post-processing, signal peaks were detected in the spectrum and assigned to known MF radio beacons. The number of received beacons is assigned to each measurement.

Figure 5 shows the track derived from the measured position data of the polish research vessel Navigator XXI for four days in September. Here, the track itself is drawn in grayscale with the intensity indicating the number of received beacons from 0 (black) to 19 (light gray) at that location.

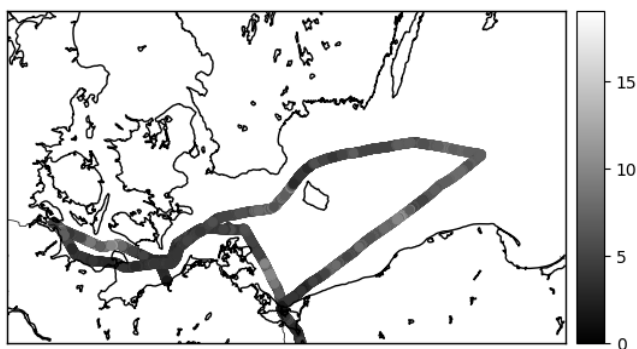

Figure 5. Track of Navigator XXI drawn in grayscale, which indicate the number of available radio beacon signals at that position.

Figure 5 indicates that most of the time more than four transmitters are visible, which is the minimum value of required signals when using the TOA positioning approach. Furthermore, the comparison with Figure 2 reveals that the number of identified beacons in the received spectrum deviates from the number in the coverage prediction. Especially in the western part of the track when the vessel was sailing along the German coastline at daytime, the number of received beacon signals is lower than the predicted number. This can be explained with the stronger attenuation of the signal caused by the lower ground conductivity of the surrounding mainland and islands which is not sufficiently reflected in the given nominal range of the radio beacons.

Furthermore, Figure 5 shows a section with a significantly increased number of received signals several times in the track. This coincides with times between sunset and sunrise. This can be explained with the impact of the skywave. During the day only those radio beacons were visible which were received as groundwave within the range of the beacon. During nighttime signals from radio beacons were additionally received which are outside the groundwave range but within the range of a reflection at the ionosphere (skywave). This effect is not considered in the coverage prediction of Figure 2.

Another way to look at the data is to plot the distance and measured field strength over time for the signal of one radio beacon. Figure 6 shows this in (a) and (b) for the German transmitter Groß Mohrdorf.

The dotted lines indicate sunset and sunrise for these days.

The effect of stronger attenuation of the signal is clearly visible for larger distances. Furthermore, there is an increase of the variance in the field strength during nighttime. This is caused by the second effective propagation path during the night, the skywave. Because the ionosphere is stable for only a few minutes, the phase and amplitude of the skywave change frequently which cause a rapidly changing superimposed signal at the receiver site.

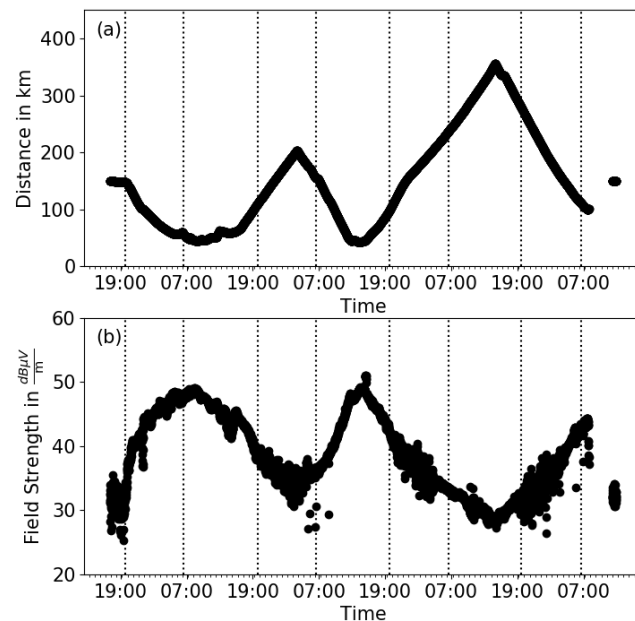

Figure 6. Distance over time (a) and field strength over time (b) for the German transmitter station Groß Mohrdorf. The dotted lines indicate times of sunrise or sunset.

For times when the vessel was near the radio beacon, the skywave has lesser impact as can be seen in Figure 6 (a) and (b) for the first night. This could be explained with the higher amplitude of the groundwave and the unfavorable characteristic of the signal propagation through the sky with respect to the transmitter and receiver antenna pattern.

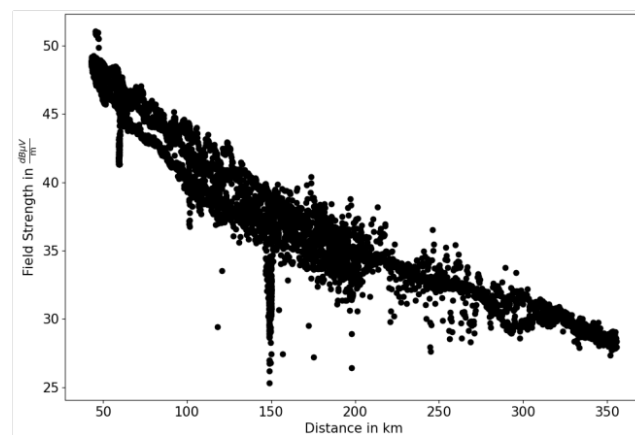

Figure 7. Field strength over distance for the German transmitter station Groß Mohrdorf.

Figure 7 shows the field strength over the distance for Groß Mohrdorf. As expected it has a linear behavior for the field strength on a logarithmic scale. For smaller distances, the variance is higher since

more measurements have been conducted at shorter distances but at different locations. Here, different propagation paths cause different attenuation of the groundwave as described comprehensively by ITU-R (ITU-R 2007).

Figure 8 shows the results for the Swedish radio beacon Holmsjö. Again the subplot (a) shows the distance from the beacon to the vessel and (b) shows the field strength over time. Times at which no signal was received appear as a gap in Figure 8 (a) and (b). Figure 9 presents the relation between field strength and distance.

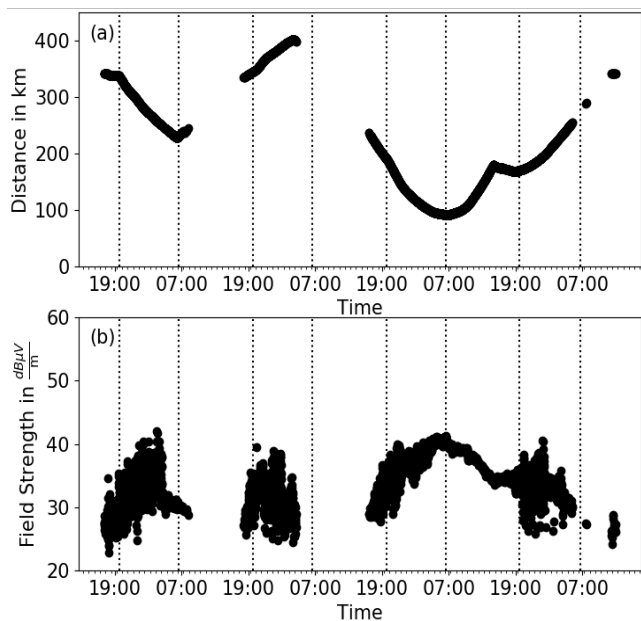

Figure 8. Distance over time (a) and field strength over time (b) for the Swedish transmitter station Holmsjö. The dotted lines indicate times of sunrise or sunset.

The main difference between the German and Swedish radio beacon is, that the Swedish is mostly at a larger distance to the vessel. It is clearly visible in Figure 8 that the signal can be received during day only at distances below 250 km. But at nighttime the visibility increases up to beyond 400 km which is caused by the skywave (first and second night).

In the morning after the first night a drop in field strength can be observed when the sky wave vanishes. As Figure 7 already indicated, the skywave effect becomes more relevant at larger distances. This is also shown in Figure 9 where a large variation in field strength appears when the field strength is plotted over the distance. For lower distances up to 250 km there is continuous reception. For larger distances the field strength does not follow the linear behavior shown in Figure 7. This confirms the static measurements presented by Hoppe (Hoppe 2018).

What does this mean for the R-Mode system? Due to the fact that a CW superimposes with a delayed copy of itself to a CW with the same frequency but different phase the occurrence of the skywave is difficult to determine. But these measurements can help to develop an indicator for skywave disturbance. As shown in Figure 6 and Figure 8 the scatter of field strength in undisturbed conditions at the day is significantly smaller than 10 dB whereas between sunset and sunrise it is typically in the order of 10 dB.

The measurements were conducted with the legacy MSK signal. They have to be repeated when complete R-Mode signals with two CW are available in the Southern Baltic Sea.

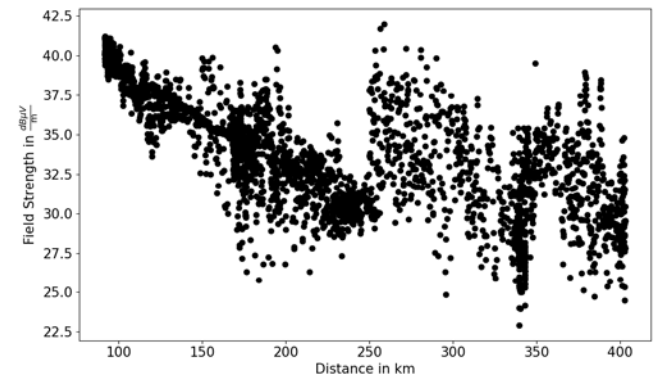

Figure 9. Field strength over distance for the Swedish transmitter station Holmsjö.

5 CONCLUSIONS

This paper introduces R-Mode as a terrestrial backup system for GNSS which can support mariners with resilient PNT information for applications which require continuous PNT data provision. The Southern Baltic Sea is a predestinated area to implement R-Mode on existing maritime radio infrastructure of radio beacons and AIS base stations. Until 2020 a testbed will be available that enables the demonstration of the R-Mode system.

A measurement campaign was performed to analyze the availability of radio beacon signals in the testbed area. The comparison of measurement results with the coverage prediction based on the nominal range reveals deviation between the number of visible radio beacons and the predicted number at day time. This is a clear indicator that this approach for the coverage prediction is insufficient. All different ground types have to be considered for adequate calculation of attenuation of the groundwave on the way to the mariner and thus the signal availability.

During the night the skywave as additional propagation path of the transmission disturbs the measurement of the groundwave. Clearly visible is the much higher number of available radio beacon signals compared to the coverage prediction and an increased scatter of the measured field strength. Monitoring the scatter can help to identify time periods of disturbed receiving conditions. One can assume that at those times MF R-Mode has a reduced performance.

ACKNOWLEDGEMENT

We thank the Maritime University of Szczecin for letting us use the Nawigator XXI for the signal strength measurements in the Baltic Sea. The R-Mode Baltic project is co-financed by the European Union through European Regional Development Fund within the Interreg Baltic Sea Region Programme.

REFERENCES

- Gewies, S., Dammann, A., Ziebold, R., Bäckstedt, J., Bronk, K., Wereszko, B., Rieck, C., Gustafson, P., Eliassen, C. G., Hoppe, M. & Tycholiz, W. 2018. R-Mode Testbed in the Baltic Sea. *Proceedings of 19th IALA Conference 2018, 27 May – 2 June 2018*. Incheon. Republic of Korea.
- Hoppe, M., Grant, A., Hargreaves, C. & Williams, P. 2018. R-Mode: The Story so far. *Proceedings of 19th IALA Conference 2018, 27 May – 2 June 2018*. Incheon. Republic of Korea.
- Hu, Q., Jiang, Y., Zhang, J., Sun, X. & Zhang, S. 2015. Development of an Automatic Identification System Autonomous Positioning System. *Sensors* 2015, 15: 28574-28591.
- IALA 2015. IALA Guideline No. 1112 on Performance and Monitoring of DGNSS Services in the Frequency Band 283.5 – 325 kHz. Edition 1 May 2015.
- IALA 2016. R-Mode Mind Map, Mind map format. *Input document to IALA ENAV19*. ENAV19-13.9.2.
- IMO 2002. Resolution A.915(22) REVISED MARITIME POLICY AND REQUIREMENTS FOR A FUTURE GLOBAL NAVIGATION SATELLITE SYSTEM (GNSS). 22 January 2002.
- ITU-R 2007. Recommendation ITU-R P.368-9 - Ground-wave propagation curves for frequencies between 10 kHz and 30 MHz. Edition 02/2007.
- Johnson, G.W. & Swaszek, P. F. 2014a. Part II - Feasibility Study of R-Mode using MF DGPS Transmissions. *ACCSEAS project report*. March 2014.
- Johnson, G.W. & Swaszek, P. F. 2014b. Part III - Feasibility Study of R-Mode using AIS transmissions. *ACCSEAS project report*. May 2014.
- Johnson, G.W., Swaszek, P. F., Hoppe, M., Grant, A. & Šafář, J. 2017. Initial Results of MF-DGNSS R-Mode as an Alternative Position Navigation and Timing Service. *Proceedings of ION GNSS+ Conference 2017*. 25-29 September 2017. Portland. USA.
- Oltmann, J.-H. & Hoppe, M. 2008. Contribution to the IALA World Wide Radio Navigation plan (IALAWWRNP) / Recapitalization of MF DGNSS Systems. *Input document to IALA ENAV4*. ENAV4-7.10 A and B.