

Reference Power Vectors for the Optical LEO Downlink Channel

Dirk Giggenbach
Inst. of Communications and Nav.
German Aerospace Center (DLR)
Wessling, Germany
dirk.giggenbach@dlr.de

Amita Shrestha
Inst. of Communications and Nav.
German Aerospace Center (DLR)
Wessling, Germany
amita.shrestha@dlr.de

Florian Moll
Inst. of Communications and Nav.
German Aerospace Center (DLR)
Wessling, Germany
florian.moll@dlr.de

Christian Fuchs
Inst. of Communications and Nav.
German Aerospace Center (DLR)
Wessling, Germany
christian.fuchs@dlr.de

Karen Saucke
Tesat Spacecom
Backnang, Germany
karen.saucke@tesat.de

Abstract—The synthesis of numerical power vectors for optical satellite data downlinks through the atmosphere to optical ground stations is described. A set of standard time series is defined and their further application for estimation of transmission performance is shown.

Keywords—optical satellite downlinks, fading and scintillation, received power, direct to earth

I. INTRODUCTION

Optical Low-Earth-Orbit satellites direct-to-Earth data downlinks (OLEODTE) [1] [2] [3] are becoming a major technological asset in future Earth-Observation (EO) missions, since the amount of data generated by the sensor payloads exceeds the available conventional RF-downlink capacity by orders of magnitude, and GEO-relays links - as an alternative repatriation option - may not be suitable for smaller EO-missions. To enable global implementation and compatible utilization of optical ground stations for direct-to-Earth (DTE) links, standardization of data formats is required. This work is currently performed inside the CCSDS (Consultative Committee for Space Data Systems) [4] [5]. Specifically, the subgroup for “Optical On/Off Keying” (O3K) is defining the physical layer (optical frequencies, modulation format, symbol-rates) and the Synchronization and Coding for O3K DTE links.

The downlink intensity of DTE links involving an atmospheric path shows fluctuations in the millisecond time scale, caused by Index-of-Refraction Turbulence (IRT) [6] and pointing jitter of the narrow beam transmitted from the satellite [7]. Therefore, the forward error correction coding and inter-leaver technique of the data stream must not only enhance overall reception sensitivity in Gaussian noise [8], but also cope with such fluctuations that eventually cause frequent and strong fading events. To enable comparable performance investigations by simulation of different channel-coding and inter-leaver schemes, a set of representative received power vectors has been defined, based on models and measurements on the respective signal parameters. It is of uttermost importance for further evaluation of different FEC schemes, that always exactly the same fading received power vectors are employed, since subtle variations in absolute fading behaviour can otherwise cause to misleading evaluation results.

We show here the method to estimate the needed channel parameters, the simulation method, and describe the characteristics of the reference received power vectors (PV). Application in estimating the performance of a Forward Error Correction (FEC) scheme is shown, as well as necessary further steps.

II. CHANNEL PARAMETERS ESTIMATION

A. Parameters for OLEODTE-Channel estimation

Necessary channel parameters for describing the received signal time behavior in an optical satellite downlink include:

- Power Scintillation Index „PSI“ (variance of signal scintillation, normalized to mean power), to model the lognormal atmospheric scintillation distribution. This must regard aperture averaging from an accordingly sized receiver telescope.
- Scintillation time-behavior, i.e. estimating its bandwidth, also reasonably well defined by its auto-covariance Half-Width at Half-Maximum $ACOV_{HWHM}$.
- The laser beam’s residual pointing jitter and jitter angle behavior result in fades. By estimating a Gaussian intensity profile and normal pointing error with equal deviation in all directions, this results in a beta-distributed fading component.
- The time-behavior of this pointing jitter, again denoted by its bandwidth or $ACOV_{HWHM}$.

The first two components are elevation-dependent, and measured values are found in [9] for 847 nm wavelength or [10] for 1550 nm, and in [11] a comparison of measured with modelled values is shown. Further measurement data are given in [12].

The latter two components only depend on system parameters of the space terminal and the ground station in a simplified approach, and slower behavior is assumed mainly to insert a slower fading component which shall challenge the further error-correction algorithms.

B. Chosen Parameter Values

For the relevant scaling parameters (fading-bandwidth, scintillation indices, jitter-strength) we assume a signal

wavelength of 1550 nm and a ground station with a receiver aperture of 40 cm being located at medium altitudes (600 m a.s.l.). One PSI value is 0.4 as found for 5° elevation, other is 0.1 as typically found at 15° elevation. For scintillation-speed we pick 1 ms $ACOV_{HWHM}$ as typically measured with KIODO-downlinks (referring to 120 Hz 3 dB scintillation bandwidth), and as second value we use 3 ms, since slower variations have to be assumed for the longer wavelength 1550 nm (referring to 40 Hz bandwidth).

We assume a jitter such, that $\beta = \theta^2 / (4 \cdot \sigma^2)$, where θ is $1/e^2$ radius of the Gaussian beam, and σ is the rms-value of the pointing jitter in one plane. With this definition, the distribution function (PDF) of the received power fading due to pointing jitter becomes $p(I) = \beta \cdot I^{(\beta-1)}$.

For one set of parameters, no pointing jitter was assumed, for another we assumed a β of 3.

Temporal jitter behavior was assumed as 10 Hz bandwidth or ~ 8.5 ms $ACOV_{HWHM}$, estimated as a compromise between high performance and less complex system.

These three pairs of parameter values thus define eight different cases or reference vectors.

III. SIMULATION TOOL PVGET

The simulation tool PVGeT (Power Vector Generation Tool) developed by DLR is based on numerical generation of scaled random variables for the lognormal atmospheric intensity (power) scintillation process, as well as for the β -distributed pointing-jitter process - where the algorithm assumes a Gaussian beam profile and equal jitter in both angular directions. Both of these processes are assumed independent and thus are multiplied for generating the final received power time series. The algorithm is described in detail in [13], and Fig. 1 repeats its principle functionality.

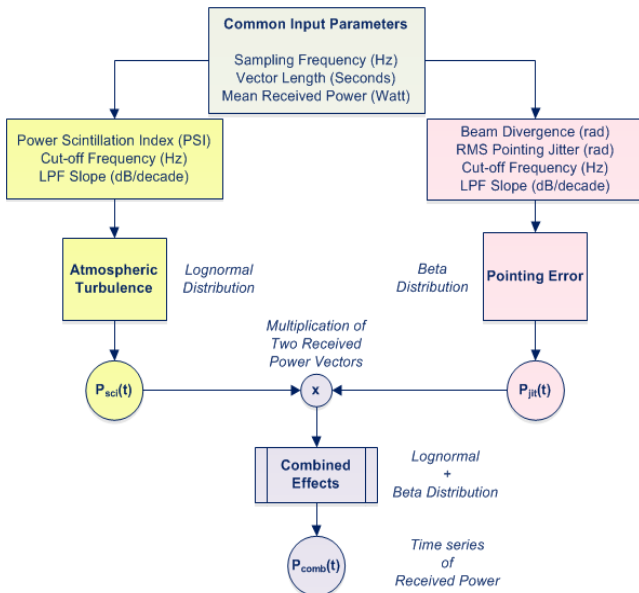

Fig. 1. The PVGeT algorithm

IV. STANDARD DOWNLINK VECTORS

A. Chosen Set of Reference Vectors

Eight vectors are generated using the PVGeT script that emulates different conditions of OLEODL scenario like weak or strong scintillation, with or without pointing error, highly or less temporally correlated channel. All vectors are of lengths 100 seconds and sampling rate of 10,000 values per second. Other parameters used for these vectors are listed in Table I. The name of the power vectors uses the atmospheric PSI, the atmosphere correlation time, and the β -value.

TABLE I. INPUT (IN) AND OUTPUT (OUT) PARAMETERS

(Name) PSI-HWHM- β^a	BW-IN atmos / β	PSI- OUT	ACOV _{HWHM} (OUT)	β (OUT)
(A) 0.1-1-inf	120 Hz / NA	0.1	1.05 ms	977
(B) 0.4-1-inf	120 Hz / NA	0.4	0.95 ms	1021
(C) 0.1-3-inf	40 Hz / NA	0.1	3.15 ms	961
(D) 0.4-3-inf	40 Hz / NA	0.4	3.05 ms	990
(E) 0.1-1-3	120 Hz / 10 Hz	0.17	1.65 ms	3.06
(F) 0.4-1-3	120 Hz / 10 Hz	0.49	1.15 ms	3.02
(G) 0.1-3-3	40 Hz / 10 Hz	0.17	4.25 ms	3.04
(H) 0.4-3-3	40 Hz / 10 Hz	0.5	3.25 ms	3.02

^a. PSI-HWHM- β values used in the name of the power vectors are input parameters.

B. Detailed description of one selected vector

We selected one vector '(E) 0.1-1-3' to describe in detail. It bears moderate scintillation with PSI = 0.1 and $ACOV_{HWHM}$ of 1 ms and includes residual pointing jitter. Detailed parameters of vector (E) are listed in Table II.

TABLE II. PARAMETERS OF VECTOR '(E) 0.1-1-3'

Parameters	Values
Vector length	100 s
Sample Rate	10,000 samples per second
Mean Vector Power	0.749 [-]
PSI of combined vector	0.17 [-]
HWHM of combined vector	1.65 ms
HWHM of atmosphere only	1.05 ms
LowPass atmosphere only	120 Hz
HWHM Pointing only	8.35 ms
LowPass Pointing only	10 Hz

The vector is further analyzed and corresponding figures are presented below. Fig. 2 and 3 shows a 1s excerpt of the power vector (E) and depict how the signal fluctuates in terms of the running min, max and mean value. Fig. 4 and 5 are PDFs of the underlying lognormal distribution (without pointing error) and pointing error distribution respectively. The figures also confirm that the generated PDFs match with the analytical ones. Fig. 6 and 7 show PDF and spectrum of the combined vector respectively. The lognormal vectors without pointing errors are normalized to the mean power of 1. Once the pointing error is introduced, mean power of the vector is not equal to 1. Therefore, the vectors (A), (B), (C) and (D) have mean value almost equal to 1 (negligible pointing error), and vectors (E), (F), (G) and (H) do not have mean power of 1. However, for the fading analysis (Section C) of the vectors (Fig. 2, 3, 8 and 9), they are re-normalized to mean power of 1. Since OLEODL channel is a

scintillating and fading channel, various error correcting codes can be employed for compensation, and they can be dimensioned using channel information like fade length, number of fades, and fractional fade time etc. as presented in Fig. 8 and 9 for vector (E).

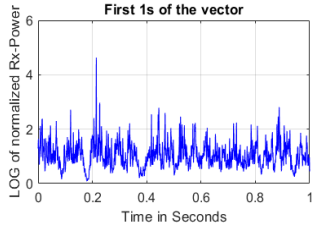

Fig. 2. First 1s of the power vector E

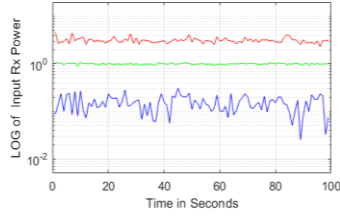

Fig. 3. min, max and mean of vector (E) using sliding window of 1s

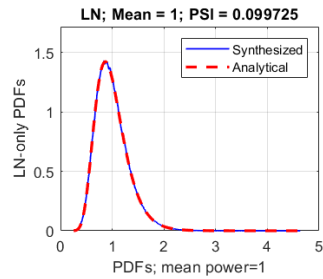

Fig. 4. PDF of the atmos. scint., compared with the analytical curve

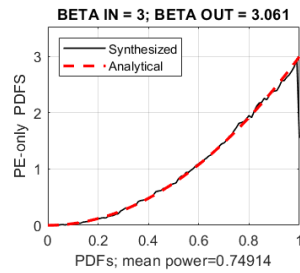

Fig. 5. PDF of the pointing error only compared with the analytical curve

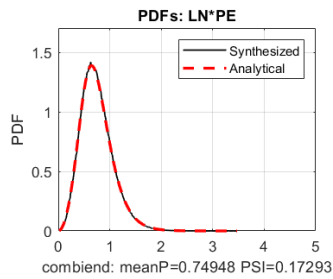

Fig. 6. PDF of the combined vector

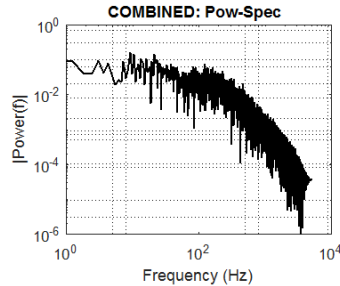

Fig. 7. Spectrum of combined vector

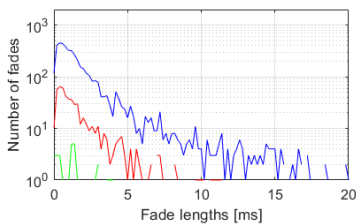

Fig. 8. Histogram of the fade length of the PV (E). Blue line is for 3dB, red for 6dB and green for 10dB fades.

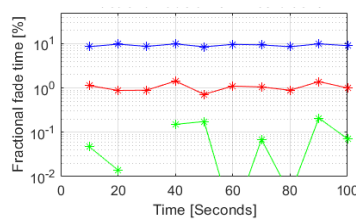

Fig. 9. Fractional fade time calculated in 10s blocks. Blue line is for 3dB, red for 6dB and green for 10dB fades.

C. Fading Statistics of all Vectors

Fading statistics of the channel represents important features of the channel. The statistics here include fade length (duration of fades), number of fade and fractional fade time. Each parameter is calculated for 3dB, 6dB and 10dB fades, and is listed in Table III. These values provide knowledge about the channel and help dimensioning error correcting codes to compensate fades.

TABLE III. FADING STATISTICS

Name	FadeLength /ms 3dB/6dB/10dB	No. of Fades 3dB/6dB/10dB	Fract. FadeTime /% 3dB/6dB/10dB
(A)	0.81/ 0.46/ 0	2187/ 3/ 0	1.7/ 0/ 0
(B)	1.36/ 0.79/ 0.38	13458/ 2168/ 17	18.34/ 1.7/ 0
(C)	2.43/ 1.7/ 0	787/ 1/ 0	1.9/ 0/ 0
(D)	3.9/ 2.3/ 1.7	4623/ 789/ 4	18.27/ 1.82/ 0
(E)	2.1/ 1.9/ 2.1	4374/ 534/ 34	9.2/ 1.05/ 0.07
(F)	1.78/ 1.28/ 1.13	12734/ 3509/ 272	22.66/ 4.49/ 03
(G)	5.45/ 4.37/ 3.5	1691/ 230/ 16	9.2/ 1/ 0.05
(H)	4.87/ 3.5/ 2.7	4857/ 1240/ 115	22.36/ 4.35/ 0.31

V. APPLICATION FOR CODE PERFORMANCE SIMULATION

Main motivation for using a measured/synthesized power vector is to emulate the real OLEODL channel so that various error correcting schemes can be evaluated and the most appropriate ones can be selected. Currently, one is working on the CCSDS standardization of coding and synchronization layer for LEO to ground optical link scenarios (O3K physical layer and S&C blue book). These vectors are being used by various CCSDS affiliated space agencies to simulate their proposed schemes. In addition to the power vectors, the receiver noise model (shot-noise limited, thermal-noise limited, or realistic avalanche photodiodes) is also necessary to be used in the simulations [14]. Also, absolute link budget calculations must provide values of received mean power, which would be dependent on further parameters like elevation, aperture sizes, signal divergence, or atmospheric transmission, etc. However, link budgets, receiver model, and simulation results are out of the scope of this paper. A general block diagram of the bit-wise simulation process for coding and interleaving schemes is shown in Fig 10. At first, bit-stream (b_{frame}) of zeros and ones is generated, encoded and interleaved, then interleaved codewords are transmitted through the optical channel (in this case defined by the power/fading vectors). These distorted signals arrive at the receiver and depending on various receiver parameters; output currents (I_{Rx}) are calculated and stored. The I_{Rx} vector is then decided using threshold level (I_{th}), and the output bit-stream (b_{out}) is generated. Output codewords are then de-interleaved, followed by decoding, where decoding fails when too many erroneous bits are recovered. Finally, input and output bit-streams are compared to calculate number of bit errors, symbol error rates, and codeword error rates, for different coding schemes. Simulations can be performed for different receiver types.

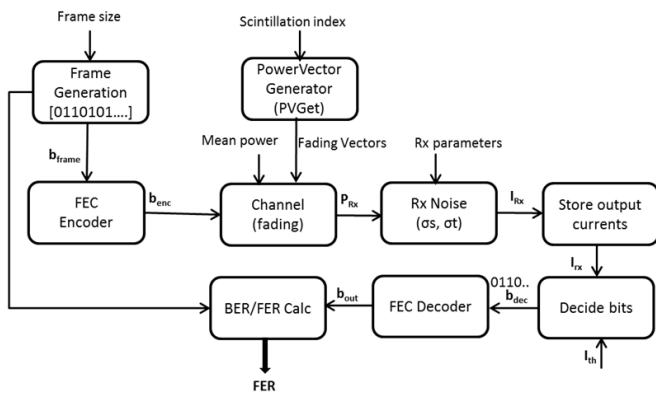

Fig. 10. Simple Block diagram for simulating various error correcting techniques using power/fading vectors and receiver models. FEC: Forward error correction, Rx: Receiver, FER: Frame Error Rate, BER: Bit Error Rate, Calc: Calculation.

VI. OUTLOOK TO APPLICATION

We have defined eight vectors of received power variations for the O3K-scenario in CCSDS standardization, to enable simulative comparison of Error Correction Schemes. These are available for download, upon request to the authors. Further work will include the definition of a suitable receiver frontend modelling, which translates the received optical power into an electrical signal value. This conversion depends on the receiver technology employed, namely if *thermal-noise limited* detectors, or *coherent* receivers, or *receivers with signal-dependent noise components* are employed. In the scenario for O3K it has to be assumed that avalanche photodiodes are used, which practically exhibit partly signal-dependent noise behavior.

Another important step would be the numerical derivation of a set of *uplink* power vectors, since these will be necessary to estimate the return channel e.g. in ARQ-algorithms.

REFERENCES

[1] D. Giggenbach, F. Moll, C. Fuchs, C. Schmidt, A. Shrestha, "Optical on-off keying data links for low Earth orbit downlink applications",

Chapter 11 in 'Satellite Communications in the 5G Era', Editors S. K. Sharma, S. Chatzinotas, P.-D. Arapoglou

[2] C. Fuchs, C. Schmidt, J. Keim, F. Moll, B. Roediger, M. Lengowski, S. Gaißer, D. Giggenbach, "Update on DLR's OSIRIS Program and first results of OSIRISv1 on Flying Laptop", Proceedings of SPIE 10910, 2019.

[3] D. Giggenbach, A. Shrestha, C. Fuchs, C. Schmidt, F. Moll, Florian, "SYSTEM ASPECTS OF OPTICAL LEO-TO-GROUND LINKS", Int. Conf. on Space Optics (ICSO), 18-21 Oct. 2016, Biarritz, France

[4] CCSDS-website <https://public.ccsds.org/Publications/default.aspx>

[5] B. Edwards, K.-J. Schulz, J. Hamkins, et al, "An Update on the CCSDS Optical Communications Working Group", 2017 IEEE Int. Conf. on Space Optical Systems and Applications, ICSOS 2017, Naha, Japan

[6] L.C. Andrews, R.L. Phillips, C. Young Hopen, "Scintillation model for a satellite communication link at large zenith angles" Optical Engineering 39 (12), 2000

[7] M. Toyoshima and K. Araki, "Effects of time averaging on optical scintillation in a ground-to-satellite atmospheric propagation," Appl. Opt., vol. 39, no. 12, pp. 1911–1919, 2000

[8] TM SYNCHRONIZATION AND CHANNEL CODING — SUMMARY OF CONCEPT AND RATIONALE", CCSDS 130.1-G-2, 2012

[9] T. Jono, Y. Takayama, N. Perlot, D. Giggenbach, et al, "Report on DLR-JAXA Joint Experiment: The Kirari Optical Downlink to Oberpfaffenhofen (KIODO)", Book by JAXA and DLR, April 2007, ISSN 1349-1121

[10] F. Moll, D. Kolev, M. Abrahamson, C. Schmidt, R. M. Calvo and C. Fuchs, "LEO-ground scintillation measurements with the optical ground station Oberpfaffenhofen and SOTA/OPALS space terminals", Proceedings of SPIE 9991, 2016

[11] D. Giggenbach and F. Moll, "Scintillation Loss in Optical Low Earth Orbit Data Downlinks with Avalanche Photodiode Receivers", IEEE-Xplore, Int. Conf. on Space Optical Systems 2017 (ICSOS), 14-16 Nov 2017, Naha, Japan.

[12] H.T. Yura and D.A. Kozlowski, "Low Earth orbit satellite-to-ground optical scintillation: comparison of experimental observations and theoretical predictions", Optics Letters, Vol. 36, No. 13, July 2011)

[13] D. Giggenbach, S. Parthasarathy, A. Shrestha, F. Moll, R. Mata Calvo, "Power Vector Generation Tool for Free-Space Optical Links – PVGeT", IEEE-Xplore, Int. Conf. on Space Optical Systems 2017 (ICSOS), 14-16 Nov 2017, Naha, Japan

[14] D. Giggenbach, R. Mata-Calvo, "Sensitivity Modeling of Binary Optical Receivers", Applied Optics, Vol. 54, No. 28, pp 8254-8259 / October 1, 2015