

# AN INTERNAL INSTRUMENT CALIBRATION SIMULATOR FOR MULTI-CHANNEL SAR

Marwan Younis, Felipe Queiroz de Almeida, Sigurd Huber, Christopher Laux, Michele Martone, Michelangelo Villano, and Gerhard Krieger

German Aerospace Center (DLR), Oberpfaffenhofen, Germany

## ABSTRACT

The increasing complexity of multi-channel SAR sensors and the real-time on-board phase/amplitude correction requirement pose new challenges for the calibration, which cannot rely on state-of-the-art calibration techniques. On the other hand, the digital hardware utilized in multi-channel SAR systems, offer new opportunities for the calibration such as on-board error correction and digital calibration. This paper addresses the internal calibration strategy for future digital beamforming SAR instruments and details the implementation of a dedicated calibration simulator software.

**Index Terms**— calibration, multi-channel calibration, internal SAR calibration, SAR internal errors

## 1. BASELINE INSTRUMENT

A multi-channel SAR instrument utilizing digital beamforming similar to the Sentinel-1 Next Generation instruments [1, 2] is considered here. The planar direct radiating SAR antenna consists of multiple antenna elements in along-track (azimuth) and across-track (elevation) direction, where each antenna element is equipped with Transmit/Receive Modules (TRM) as shown in Fig. 1. In principle, the calibration approach can equally be applied to the digital feed array of a reflector based system, however a reflector system behaves different and the calibration performance may be different [3].

On-transmit, phase spoiling is applied to get an antenna beam wider than what would normally be the case for a large antenna; this is because all the TRMs are active, i.e. transmitting. The reflected echo signal is received by the antenna elements, amplified, TRM outputs partially combined, and the resulting  $N_{az}N_{el}$  signals filtered, down-converted and digitized, forming a total of  $N_{az}N_{el}$  data streams, respectively. First, digital beam-forming is applied on-board through Scan-On-REceive (SCORE) in elevation [4]. Second, MACS (Multiple Azimuth Channels) requires reconstructing the Doppler spectrum from the undersampled azimuth channels data [5], which is applied on-ground.

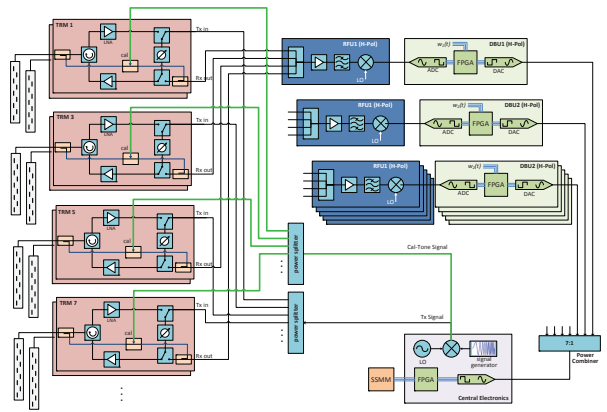

**Fig. 1.** Instrument and calibration schematic of multiple elevation channels corresponding to a single azimuth tile and being combined through SCORE. The cal-tone injection path is shown in green.

The instrument schematic for one azimuth channel is shown in Fig. 1. Focusing on the receive case, the reflected radar echo excites the antenna elements and the received signals are then passed through the TRMs for amplification and possible phase/amplitude setting. The signals comprising one elevation channels are combined in the Radio Frequency Units, thus  $N_{el}$  RFUs per azimuth channel and polarization are used, where the signals are further amplified, filtered, and down converted to IF. The output signal of each RFU is then digitized in the Digital Beamforming Unit which also applies the digital time varying weights necessary for SCORE operation. The output signals of each DBU are, however, analog (see DAC within DBU) which are then combined and, again, digitized within the CE so that it can be stored in the SSMM.

## 2. CALIBRATION CONCEPT

The main characteristic of the suggested calibration concept is that it avoids the typical interruption of SAR operation when injecting the calibration signal –which would cause lost imaging pulses or a reduction in swath width–, and that it allows for on-board channel correction [1, 6].

The work is carried out under a contract with the European Space Agency (ESA/ESTEC) ESA ITT AO/1-8469/15/NL/FE

## 2.1. Cal-Tone

A single tone (i.e. single frequency) signal outside the SAR signals chirp bandwidth, which can be injected into the receive path of the SAR echo signal without disturbing SAR operation. Using these single tone calibration signals the calibration methodology for the instrument including the front-end TRMs, the radio frequency unit (RFU), the digital beam-forming unit (DBFU), and the CE as shown in Fig. 1. It should be noted that the calibration concept is of limited sensitivity to variations within the chirp bandwidth, but the frequency of the cal-tone can be varied on a pulse-to-pulse basis to successively characterize the transfer function at various frequencies. It is suggested that even if the cal-tone falls within the spectrum of the chirp signal, it can be extracted within the DBFU unit, thus not affecting SAR image quality.

## 2.2. Transmit/Receive Module Calibration

As shown in Fig. 2 a separate TRM-injection point, which is different from the Tx-signal input, is chosen for the cal-tone. The TRMs allow routing the cal-tone through two different paths: As shown in Fig. 2, to characterize the receive path the cal-tone is routed through the output coupler into the receive path including the LNA, phase shifter, attenuator (analog phase/amplitude setting) and the remaining Rx path. The Short-Cal path on the other hand is used to measure the receive path excluding the contribution of the TRM itself, which allows extracting the individual TRM contribution to the instrument drift.

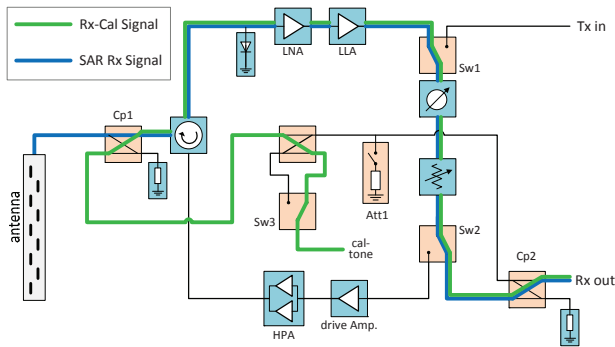
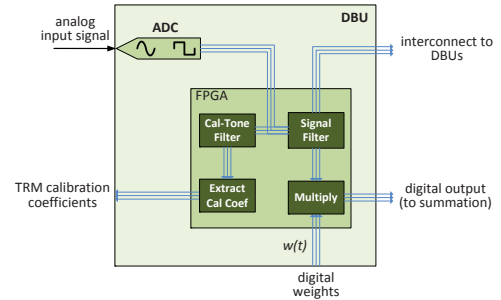

**Fig. 2.** Schematic of TRM showing the cal-tone injection for measurement of the receive path (Rx-Cal).

Advantages of the calibration concept are: it simplifies the TRM design and increases reliability by reducing the number of switches in the signal path; it allows for simultaneous SAR operation and calibration, i.e. uninterrupted SAR operation; and the concept makes extensive use of the on-board digital processing capabilities to measure and correct the instrument drifts in real time

## 2.3. Digital Beam-Forming Unit

In the following the required functionality of the Digital Beamforming Unit (DBU) is addressed, c.f. Fig. 1. Each DBU represents one digital channel of the system; its input is the IF output signal of the RFU which is digitized, filtered, and multiplied by a complex (digital) time varying weight, Fig. 3 shows the schematic of the DBU.



**Fig. 3.** Schematic DBU showing the FPGA and the various input/output lines.

The outputs of all DBUs within one antenna column are summed yielding a single data stream. In addition, the FPGA (or ASIC) of the DBU needs to do the computations necessary to calibrate the system. This includes the extraction of the cal-tone (filter) and computing correction coefficients by comparing the cal-tone to a reference tone or to the cal-tones of the other DBUs utilizing the interconnection lines between the DBUs. The phase and amplitude correction coefficients are passed to the respective TRMs. In addition, the DBUs need to generate calibration signals, which are passed through the subsequent stages in order to calibrate the hardware implementing the SCORE (i.e. up to the CE). Last but not least, the correction of these subsequent hardware is done in-advance within the DBU.

## 3. CALIBRATION SIMULATION TOOL

The calibration of a multi-channel SAR instrument with mixed analog (i.e. Tx/Rx-Modules) and digital beam-forming is a complex task. The be able to assess and optimize the performance of different calibration strategies and schemes a calibration simulator CalSim is being designed and implemented.

The simulator is implemented in a generic object oriented programming approach, where each unit of the system is described by a set of parameters characterizing its behavior over frequency (frequency transfer function), time, and temperature (drift). The signal path is sub-divided into layers such that each layer contains one or more similar components (or sub-units), which are described through classes, cf. Fig. 4.

Each component may have individual parameters set during the initialization of the objects instance. For example an

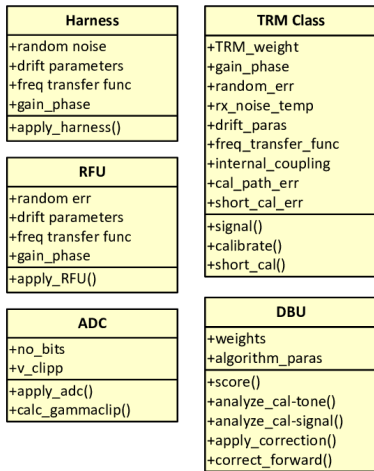

Fig. 4. Modeling the units through object-oriented classes

ADC may be described through its number of bits and the clipping voltage. The components affect the signals passing through it, which is modeled as methods of the class.

The implementation models the instrument hardware including its imperfections affecting the SAR signals in addition to the calibration sequence itself and the algorithms used to extract the correction factors. The aim is to estimate the effect of the instruments imperfections on the final SAR performance. For some special cases this can be determined analytically [7], however, specifically in the case of a real-time on-board calibration the processes are no longer stationary and the assessment of the residual error is better done using simulations.

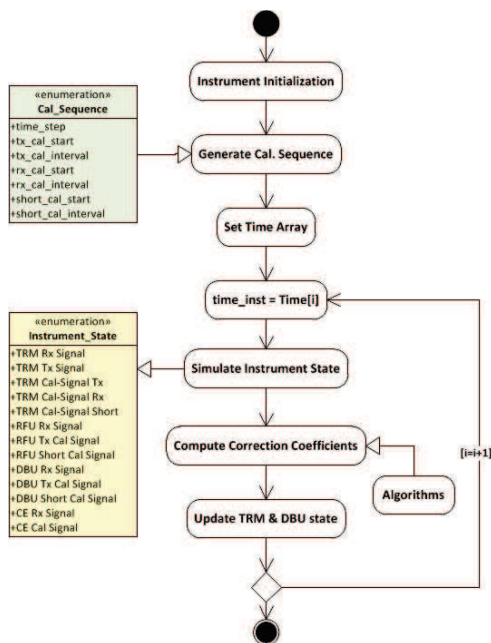

Fig. 5. Top-level flow chart of the calibration simulator.

With a realistic set of parameters based on measurements the simulation can be used to calculate the phase and amplitude errors for any time instance of the complete system. Moreover, as shown in Fig. 5, the CalSim is implemented so as to account the real-time correction algorithms, c.f. Section 2.3, and by this assess the error performance of the complete system after calibration.

#### 4. REFERENCES

- [1] "Calibration and data reduction for digital beam forming instruments – concept discussion," European Space Agency (ESA/ESTEC), technical report D1, ESA ITT AO/1-8469/15/NL/FE, Mar. 2017.
- [2] G. Adamiuk, C. Heer, and M. Ludwig, "DBF technology development for next generation of ESA C-Band SAR mission," in *Proc. European Conference on Synthetic Aperture Radar EU-SAR'2016*, Hamburg, Germany, June 2016.
- [3] M. Younis, S. Huber, A. Patyuchenko, F. Bordoni, and G. Krieger, "Performance comparison of reflector- and planar-antenna based digital beam-forming SAR," *Int. Journal of Antennas and Propagation*, vol. 2009, June 2009. [Online]. Available: <http://www.hindawi.com/journals/ijap/2009>
- [4] M. Süß and W. Wiesbeck, "Side-looking synthetic aperture radar system," European Patent EP 1 241 487, Sept., 2002.
- [5] G. Krieger, N. Gebert, and A. Moreira, "Unambiguous SAR signal reconstruction from non-uniform displaced phase centre sampling," *IEEE Geoscience and Remote Sensing Letters*, vol. 1, no. 4, pp. 260–264, Oct. 2004.
- [6] M. Younis, C. Laux, N. Al-Kahachi, P. López-Dekker, G. Krieger, and A. Moreira, "Calibration of multi-channel spaceborne SAR – challenges and strategies," in *Proc. European Conference on Synthetic Aperture Radar EUSAR'2014*, Berlin, Germany, June 2014.
- [7] F. Almeida, M. Younis, G. Krieger, and A. Moreira, "An analytical error model for spaceborne SAR multichannel azimuth reconstruction," *IEEE Geoscience and Remote Sensing Letters*, Mar. 2018.