

E.DEORBIT MISSION: OHB DEBRIS REMOVAL CONCEPTS

Gerrit Hausmann⁽¹⁾, Matthias Wieser⁽¹⁾, Richard Haarmann⁽¹⁾, André Brito⁽²⁾, Jan-Christian Meyer⁽²⁾,
Steffen Jäkel⁽³⁾, Michèle Lavagna⁽⁴⁾, Björn Jakobsson⁽⁵⁾, Robin Biesbroek⁽⁶⁾

⁽¹⁾ OHB System AG, Wolfratshauer Str. 48, 81379 Munich, Germany, gerrit.hausmann@ohb.de

⁽²⁾ OHB System AG, Universitätsallee 27-29, 28359 Bremen, Germany, marc.scheper@ohb.de

⁽³⁾ DLR Robotics and Mechatronics Center, Oberpfaffenhofen, 82234 Weßling, Germany, steffen.jaekel@dlr.de

⁽⁴⁾ Politecnico di Milano Aerospace & Science, Via La Masa 34, 20156 Milano, Italy, michelle.lavagna@polimi.it

⁽⁵⁾ OHB Sweden AB, Viderögatan 6, 164 40 Kista, Sweden, bjorn.jakobsson@ohb-sweden.se

⁽⁶⁾ ESA ESTEC, Keplerlaan 1, 2200 AG Noordwijk, Netherlands, robin.biesbroek@esa.int

ABSTRACT

To stabilize the space debris problem in low Earth orbit (LEO), the performance of active debris removal missions is required. To prepare for such missions, the European Space Agency (ESA) has initiated the e.Deorbit mission as part of its Clean Space activities, with ENVISAT as a sizing case for a potential removal target.

For the phase A of e.Deorbit, OHB System has led a team with strong heritage in the key fields of mission design, space robotics, and guidance, navigation and control (GNC).

In this paper, the mission concepts for removing space debris with a rigid or flexible capture mechanism are presented. While re-orbiting was also studied, it is not addressed in this paper.

A key focus of the study has been the creation of a cost-effective design, allowing the high number of future removal missions needed for the stabilization of the space debris environment while not sacrificing the necessary levels of reliability and safety.

1. BACKGROUND

As analyses in recent years have shown, the space debris environment in LEO can likely be stabilized if at least 5 large objects are removed from these orbits every year [1]. To prepare for such a scenario, in 2013 ESA initiated three parallel industrial studies to investigate technical concepts and business models to commercially offer active debris removal (ADR).

Following this, the Agency has started three parallel phase A studies to further investigate the technical specifics of a first operational mission. To cover a wider range of the possible mission concept options, three different concepts were sketched and analysed all along the project: one for deorbiting space debris by means of a rigid connection (Mission Option 1), one for deorbiting via a flexible connection (Mission Option 2) and one for re-orbiting the target to a graveyard orbit (Mission Option 3). The first two concepts are described in this paper.

2. TEAM AND EXPERTISE

The team assembled by OHB System has relevant heritage in all key fields of this study. OHB System's Munich site has a long heritage in robotics missions, including the robotic arm qualification project ROKVISS, the on-orbit servicing mission DEOS (phase B1 and B2), the VIBANASS camera system, the OLEV commercial space tug for geosynchronous Earth orbit (GEO) and the Active Debris Removal Service (ADRS) study for a service-based approach to ADR. OHB System's Bremen site adds the necessary expertise and heritage in the design and realization of cost-effective platforms. GNC aspects were covered by OHB Sweden, who have exceptional heritage from their PRISMA mission. For rigid capture methods, the DLR Robotics and Mechatronics Center was part of the team and detailed work on flexible capture mechanisms was performed by Politecnico di Milano.

3. REFERENCE TARGET

As sizing case for the e.Deorbit mission, the defunct ESA satellite ENVISAT was selected. Following an anomaly on 8 April, 2012 leading to the end of ENVISAT's mission, this satellite today is drifting in near sun-synchronous orbit (SSO) at an altitude of approximately 800 km. It is assumed that the satellite is in the state indicated in Figure 1, with the solar panel rotated in front of the launcher interface [2].

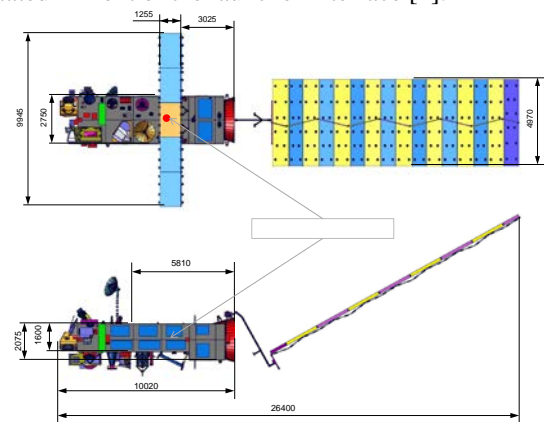

Figure 1: ENVISAT dimensions (figure: ESA)

It is further assumed that while ENVISAT's batteries have been depleted after the anomaly, the solar generator is still functioning and the harness leading into the spacecraft is still powered. ENVISAT's tanks are expected to still contain 36 kg of frozen residual propellant, as they did shortly before the anomaly.

The events of the anomaly on 8 April 2012 indicate that ENVISAT's power subsystem is defective and that its batteries are depleted. Furthermore, no signs of an active Attitude and Orbit Control Subsystem (AOCS) could be detected after the anomaly [2, 3]. We therefore assume that ENVISAT's AOCS is inactive and that the satellite will not actively resist its capture. The assumed dimensions of ENVISAT are given in Figure 1. Unless otherwise specified, all values are in mm. These assumptions are based on References 4, 5, 6, 7, and on engineering experience.

The mass of ENVISAT is estimated to be approximately 7828 kg [5]. Based on recent measurements of ENVISAT's attitude, we assume that at the time of the removal mission, the target will rotate with up to 5° per second [3]. Regarding interfaces, ENVISAT's launcher interface ring has been identified as its most suitable grapple point.



Figure 2. ENVISAT's launch adapter ring (image: ESA)

4. CAPTURE WITH RIGID CONNECTION

4.1. Investigated Capture Mechanisms

For capturing ENVISAT with a rigid connection, several combinations of robotic arms, tentacles and simple clamping mechanisms have been investigated. The trade-off reveals that concept with one arm and a fixation device is the most suitable solution for a rigid capture. The trade-off also shows that arm concepts in general are best suitable to capture uncooperative objects in space. This is mainly due to their versatility. The numerous DoF allow reacting on various situations and thus leading to moderate risk for the mission. The fixation device can either be a dedicated development or similar to one of the tentacle concepts investigated under a separate ESA contract [8].

4.2. Selected Capture Mechanism

The rigid capture system is composed of the robotic arm for capturing and stabilizing the target satellite as well as a clamping mechanism for achieving stiff force closure during the de-orbit manoeuvre. The following chapter presents the design of the arm including the attached gripper, camera system and required software. Subsequently the clamping mechanism will be presented.

The manipulator arm has stretched length of 4.2 m measured from the axis going through its base to the tip of the Gripper in closed configuration. The arm is composed of Aluminium cylindrical tubes that provide the structure for the kinematics and deal as housing for the integrated joint motor/gears, required sensors and wiring. A short base cylinder provides the interface to the Chaser platform by a bolted flange connection. The elbows of the manipulator arm are specially welded housings, providing access from the side to the interior via removable cover plates fixed on the sides.



Figure 3: Robotic arm in zero (stretched) configuration with gripper and stereo camera system attached.

The current joint design for the space-robotic manipulator is built upon heritage from the ROKVISS mission, where similar joints were tested in orbit for five years outside the Russian service module on the International Space Station (ISS). However, the designs are not identical as there has been further development and adaptations with regard to on-orbit servicing requirements. The main differences between the ROKVISS and the current robotic joints are the following:

- Integrated Electronic Blocks (EBs) in the arm, one block is controlling two joints each, the last EB is controlling one joint and the gripper
- An output position sensor has been added
- EtherCAT bus system instead of SERCOS ring
- Internal motor brake has been added

For analyzing the suitability of the chosen length configuration of the robotic arm, a reachability analysis has been conducted. For this purpose, a so-called reachability map was calculated (Figure 4). The reachability map is a discretized structure that describes the reachable poses of a robot's end-effector. For the presented kinematics, the reachability of the targeted upper side of the adapter ring is optimal from both relative satellite positions. Moreover, the chosen kinematics allows a maximum relative positioning error of 1 m to be still in the optimal reachability area. Thus, the chosen capture approach is feasible.

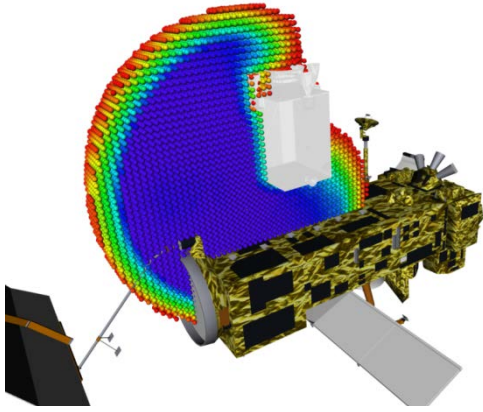

Figure 4. Robotic arm capability map with Chaser satellite in arm delivery position and all seven joints or their respective redundancy counterpart working.

The design of the gripper for e.Deorbit is very target-oriented, as the adapter ring is a structure where effective force closure must be achieved between gripper and the object to be captured. The gripper must at least support the forces and torque specification of the arm joint in order to be in line with the general arm design.

Figure 5 shows on the bottom left the gripper in initial grasp position. Due to the form of the brackets, the design is robust to possible positioning error up to ± 20 mm in x and ± 30 mm in y , while z is irrelevant through the radial form of the adapter ring. With the arm being in compliant mode during the grasp, it is pulled into the right position upon gripper closure. During de-orbit and after ENVISAT is secured using the clamping mechanism, the arm is repositioned and the round-shaped fingertips of the moving bracket can be used to hold onto the solar panel boom for position measurement and active damping of occurring oscillations.

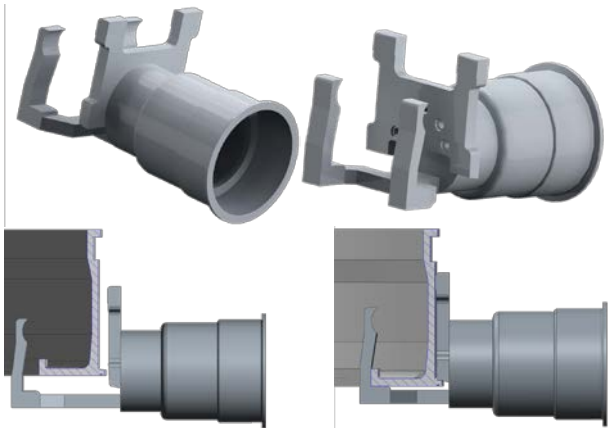

Figure 5. Different views of the designed gripper with linear moving bracket

The robotic arm features a stereo-camera system located above the arms tool center point (TCP). The following figure shows the gripper together with the camera.

Continuous grasp point observation throughout approach and grasping is achieved using the following visual features:

- Solar panel motor structure and adapter ring edges as features allowing six degree-of-freedom (6-DoF) tracking,
- Adapter ring edges in the last phase of approach allowing 5-DoF tracking.

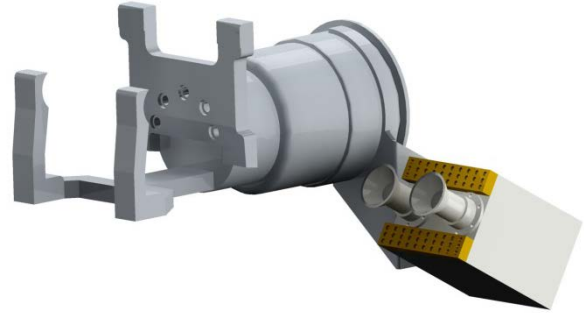

Figure 6. TCP stereo camera system with illumination units attached onto the gripper with mounting bracket

After successful synchronization between Chaser and Target satellite there will still be residual motion due to expected errors of the AOCS and vision-based sensor (VBS) pose estimation. When the target is captured with the robotic arm, this leads to occurring forces and torques in the arm joints in order to stabilize relative motion to bring it to zero.

The fixation device (Figure 7) is required to fix the Chaser satellite onto the Target satellite in seated position above the CoG, so that the de-orbit burn (450 N) can be issued in line with the CoG leading only to a translational force and dismissing the insertion of any rotational forces. The aim is to achieve stiff force closure through the clamp mechanism, as the arm is only used for re-positioning if the clamp is open. The clamp secures the fixation in lateral direction by form closure.

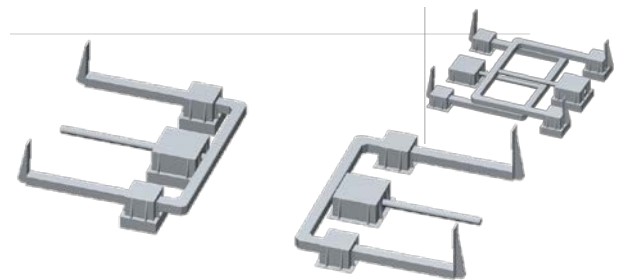

Figure 7. Clamping mechanism in opened (bottom) and closed (top) configuration

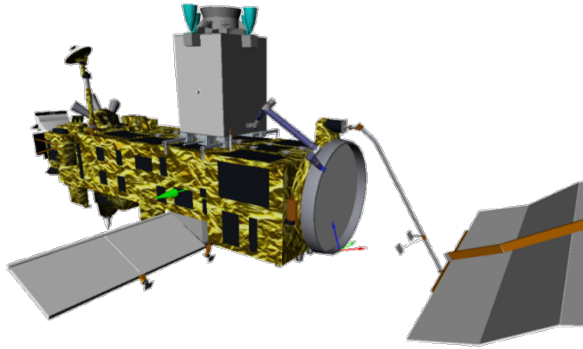

Figure 8. Chaser satellite with clamp mechanism closed positioned on top of ENVISAT

4.3. Chaser for Rigid Capture

For the robotic arm mission one liquid apogee engine is used. It is accommodated inside the launcher adapter ring. The robotic arm and clamping mechanism payload are accommodated on the opposite side of the satellite. This concept makes use of a shear-panel structure concept. Four propellant tanks are accommodated in the bottom-half of the platform. The other platform units are mounted on the top-half of the platform.

This chaser is compatible with a launch on VEGA, albeit with low margins.

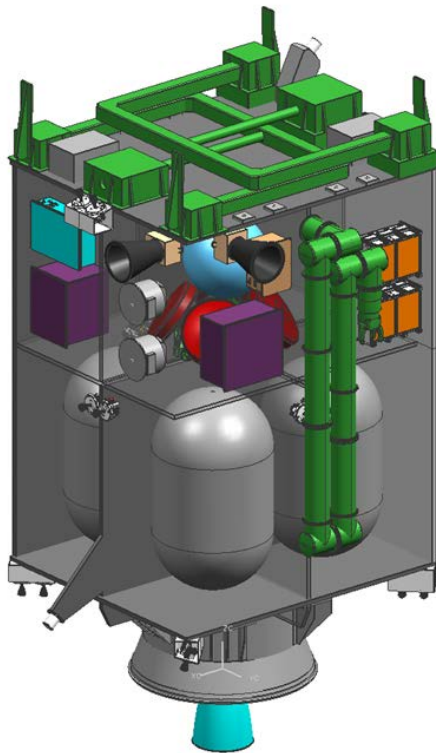

Figure 9. Accommodation of payload and platform units for rigid capture

5. CAPTURE WITH FLEXIBLE CONNECTION

5.1. Investigated Capture Mechanisms

To capture ENVISAT with flexible connections, both nets and harpoons have been investigated. The performed trade-off clearly reveals the net concept as preference for a flexible deorbit mission option. The net concept has clear advantages, especially its low costs and low demands on the chaser as well as the operation.

5.2. Selected Capture Mechanism

The main subsystems of the flexible payload are:

- a net, to create a connection between the target and the chaser
- a set of bullets to lead the net dynamics from the release to the wrapping on the target.
- a closure mechanism to increase the target retain robustness and speed of the target capture
- a tether, to create and keep the target\chaser connection during manoeuvres to dispose
- a tether service pack, to stow the tether in the chaser before the capture starts, to ensure the mechanical connection of the end of the tether with the chaser, to provide the accomplishment of emergency procedures if ever the tether detaching from the chaser is required
- an ejection mechanism, to give the net the correct relative dynamics to leave the chaser, deploy and approach the target
- a sensors and electronics pack, to monitor and control the payload behaviour.

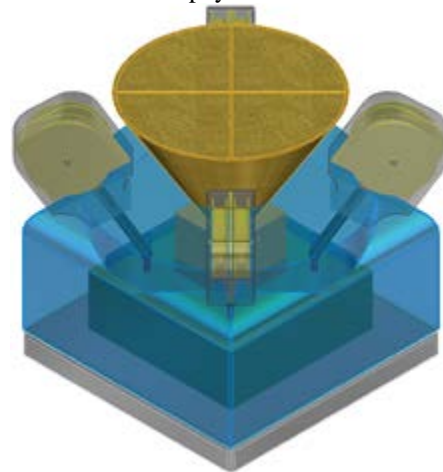

Figure 10. P/L net housing concept: isometric view

The net is the system part devoted to capturing the target and to be the interface between the target and the mechanical connection with the chaser, here represented by the tether. To ensure a complete target wrapping the net size is here assumed to be 60 m × 60 m.

The bullets represent the massive element of the net subsystem. They provide the functionalities of:

- changing the net configuration from folded on the

- chaser to deployed in space
- driving the net from the chaser to the target
- collaborating to the net closure around the target

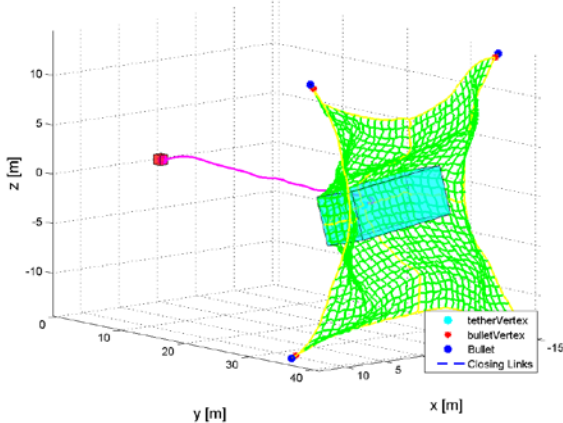

Figure 11. Image of net capture simulation

The closure mechanism has been considered and inserted in the design to answer the current requirements and functionalities:

- support the target wrapping in presence of a significant target spinning condition
- increase the clamping robustness avoiding slippages of the net on the target, if any
- speed up the wrapping phase after the net impacted the target

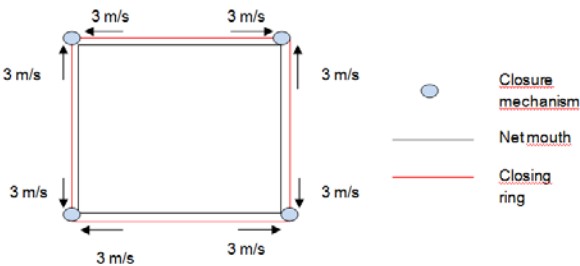

Figure 12. Net closure concept

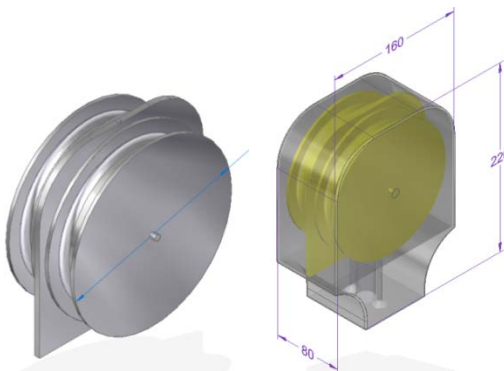

Figure 13. Double winch mechanism configuration (left) and integration within the bullet (right)

The net ejection system is the core of the net dynamics. The requirements the design must respect are:

- to impart the net the correct impulse to

- Completely deploy the net at its maximum extension before meeting the target
- To deploy the net within a minimum safe distance imposed by CAM specifications to protect the chaser in not-nominal conditions
- to ensure a limited ejection lag among the bullet detachment from the chaser, driven by the net dynamics to ensure a correct and complete deployment
- to be safe and reliable
- to be technologically ready
- to limit the payload integration and operation complexity
- to ask for a limited amount of mass, power, volume, and data handling.

For the implementation of the aforementioned functionalities two main elements have been considered: the pressurized chamber here called the barrel, which supports also the bullets, and the actuators. As actuator, Cold gas generation (CGG) technology has been here preferred to limit the high operational temperatures: CGG can be described as pressure cartridges that are activated through an initiation electrical circuit. The gas is stored in a solid form inside the pressure cartridge: providing power to the cartridge the chemical reactions that produces gas with an elevated purity is activated.

The tether design parameters include the material, the rope diameter and the length. The tether length depends on the disposal control strategy applied as it plays a fundamental role in the dynamic evolution of the composite. The selected tether length has also to be cross checked with the operational distance, along the V-bar, to assure the net completely deploys before impacting on the target; the distance, in its turn, depends on the size of the net, which is affected by the target size.

Due to the thermal conditions in the proximity of the chaser's thruster, it is planned to use silicon carbide fiber for the first 5 m of the tether's length in combination with an additional 65 m Technora fiber, bringing the overall tether length to 70 m. Analyses have shown this length to lead to a controllable system, assuming the inclusion of an adequate oscillation control strategy.

5.3. Chaser for Flexible Capture

While largely similar to the chaser with a rigid connection to the target, the chaser for the flexible capture method requires a four-engine concept due to the puller-configuration of the overall stack.

The net-equipped chaser is also compatible with a launch on VEGA.

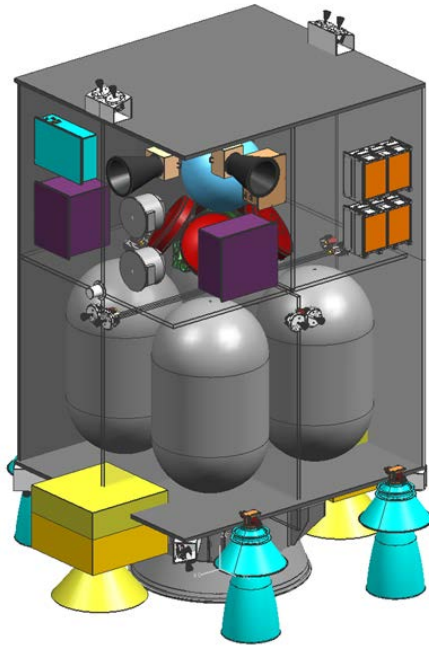

Figure 15. Accommodation of payload and platform units on net-equipped chaser

6. WAY FORWARD

6.1. Selection of Preferred Variant

A System Concept Trade-Off has been performed as the final trade-off between the two presented mission options, which have been investigated during the e.Deorbit Mission Phase A study. Its objective is to determine the most promising concept for the mission, considering costs and risks.

For the final trade-off between the three mission options only risk and costs have been considered.

The operational costs have not been considered in the final trade-off. They are assumed to be nearly equal as the mission durations of both mission options are nearly equal, too.

The Risk criterion is weighted more than Costs. From the view of the study team it is more important to focus on the risk level, than on costs. For that reason the risk and cost numbers are first normalized and then a weighting factor of 2 is applied to the risk-credits while the Cost-credits are weighted with a factor of 1. For each criterion 1 to 5 credits are given. The trade-off reveals that Mission Option 2 “Arm Capture + De-orbit” is the preferred concept for the e.Deorbit Mission.

6.2. Potential Commercial Applications

While being more favourable with respect to development risk, the robotic arm’s flexibility offers later applications of this concept for different mission types, including servicing missions in LEO and in GEO. Such applications have already been investigated in the scope of the ADRS study.

However, due to the long development time and the

resulting development cost, the potential commercial promises apparent today are not sufficient to raise the necessary capital for an industry-led and privately funded development of operational ADR systems. Therefore it is critical for European industry that publicly-funded and relevant mission such as e.Deorbit are implemented to allow a preparation of the key technologies for a later realization of large-scale ADR.

7. ACKNOWLEDGEMENTS

DEOS was funded by the German DLR Space Administration.

ADRS, the tentacle-based clamping mechanisms and the e.Deorbit mission phase A have been funded by ESA.

The development of OLEV was performed with internal financing and co-funding from ESA and the DLR Space Administration

VIBANASS was funded internally and co-funded by the DLR Space Administration (50RA1001) and carried out in cooperation with the DLR Institute for Mechatronics and Robotics and the DLR Institute for Space Operations and Astronaut Training.

8. REFERENCES

1. 6th IAASS Conference, “The Space Debris Environment and its Evolution”, H. Klinkrad, ESA Space Debris Office, 21.05.2013
2. ‘ENVISAT – The End of a Successful Earth Observation Mission’ presentation by Frank-Jürgen Diekmann and Holger Krag at the Workshop on Active Space Debris Removal, ESOC, Darmstadt, Germany, 17 September 2012
3. ESA Memo ‘Evolution of ENVISAT’s Attitude State’, GSP-ENV-TN-00121-HSO-GR, 12.12.2013
4. e.Deorbit CDF Study Report, CDF-135 (A), Issue 5
5. ESA Bulletin 106, June 2001
6. ENVISAT-1 Mission & System Summary, ESA, March 1998
7. ENVISAT-1 Mission & System Summary, ESA, March 1998
8. IAC-14,A6,5,1 “Clamping mechanism – a tentacles-based capture mechanism for active debris removal”, J-C. Meyer, M. Scheper, R. Janovksy, J. Vazquez Mato, G. Taubmann, J. Cavia Eguen, R. Le Letty, 29 Sep – 3 Oct 2014