

# Development of a molten salt system for thermal energy storage at elevated temperatures

Nicole Pflieger, Thomas Bauer, Markus Braun, Markus Eck, Doerte Laing



# Overview

- Characterization of salt systems:
  - thermal stability
  - thermodynamical properties ( $C_p \sim$  costs)
  - availability
  - handling
- Optimization of salt system:
  - reducing the melting temperature for increased storage capacity:
    - traditional approach
    - new method



# Definition of salt system

cations:

single element cations:

-> no decomposition for cations takes place

anions:

- sulfate

- carbonate

- fluoride/ chloride/ bromide/ iodide





## Extent of theoretical research:

anion groups	:	6
single salts	:	50
salt mixtures	:	180

## Result of anion groups:

Fluoride  $F^-$   
Bromide  $Br^-$   
Iodide  $I^-$  }

→ toxic/ corrosive

→ expensive

Carbonate  $CO_3^{2-}$   
Chloride  $Cl^-$   
Sulfate  $SO_4^{2-}$  }

→ suitable



## Carbonate



- High thermal stability  
>1200 °C
- High heat capacity  
>1.5 J/gK
- Not corrosive

## Chloride

- High thermal stability  
> > 1200 °C
- Cheap

## Sulfates

- High thermal stability  
>1000 °C
- High heat capacity  
>1.2 J/gK



- High melting point  
>800 °C

- Low heat capacity  
(~1 J/ gK)
- Quite corrosive
- High melting point

- High melting point  
>880 °C



# Reduction of melting point

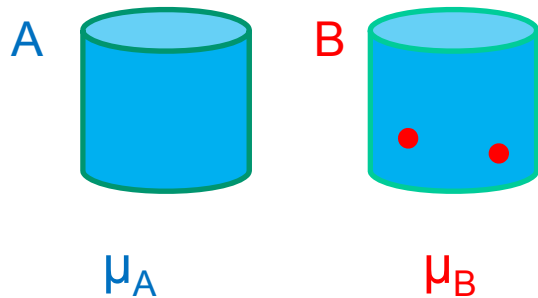

$x :=$  ratio of second component

$$(d\mu/dT)_p = -S$$

$$\mu_B - \mu_A = RT \ln(1-x);$$

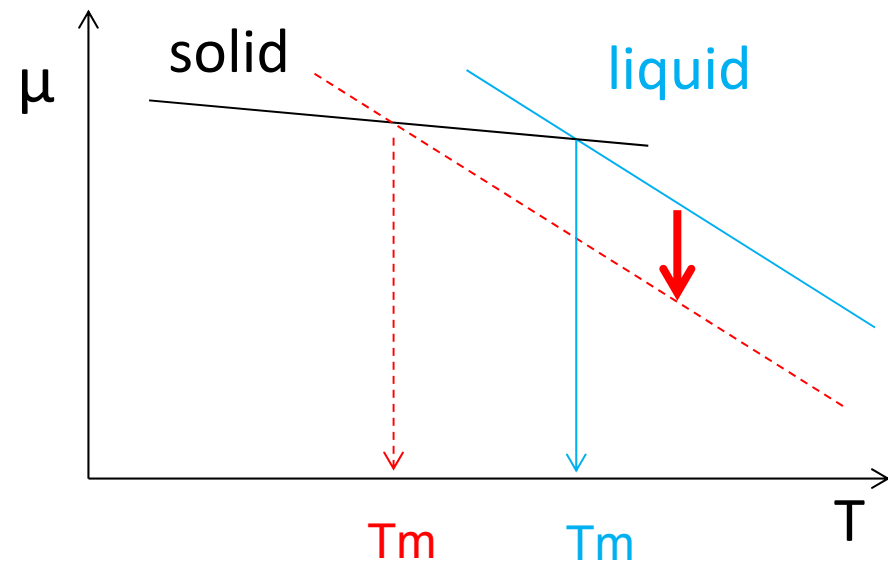

→ Mixing reduces  $T_m$  (if component is insoluble in the solid)



# Reduction of melting temperature by high throughput screening

Determination of melting temperatures of samples by DSC (differential scanning calorimetry)

- Advantage:
  - Applicable to all conceivable salt mixtures
- Disadvantage:
  - For every system numerous salt compositions have to be analyzed

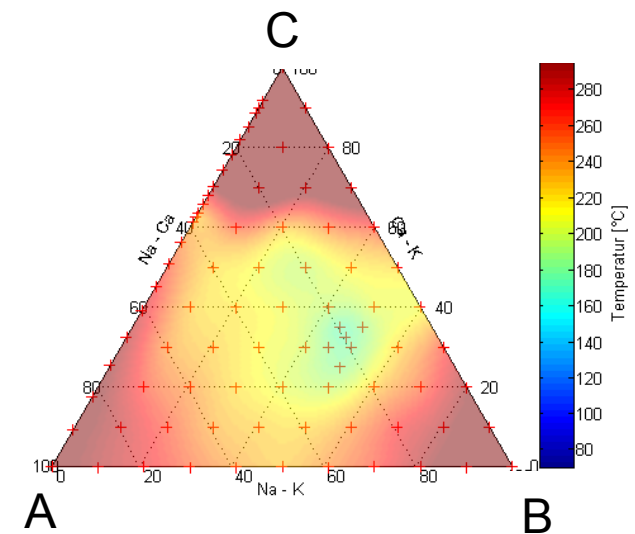



# Binary systems

Temperature dependency and composition dependency: - number and type of phases

- ratio  $^{liquid}/_{solid}$

- ratio  $^{[A]}/_{[B]}$

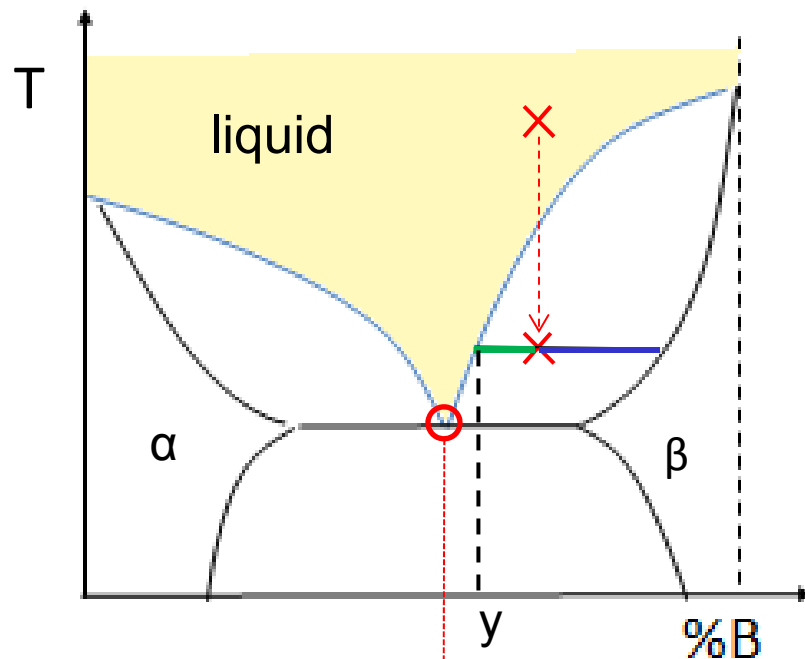

→ Reduction of the temperature  
changed composition of liquid phase

composition with lowest melting temperature



# Innovative synthesis

- Preparation of pellet with A and B

- Slow heating

$$T \approx T_{\text{melt}}$$

- Liquid phase formation

+ detection

(by electric resistance)

- extraction

(by applying vacuum)

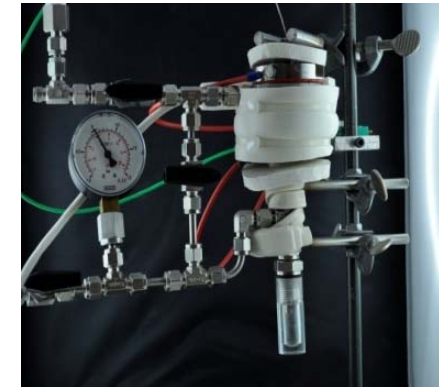
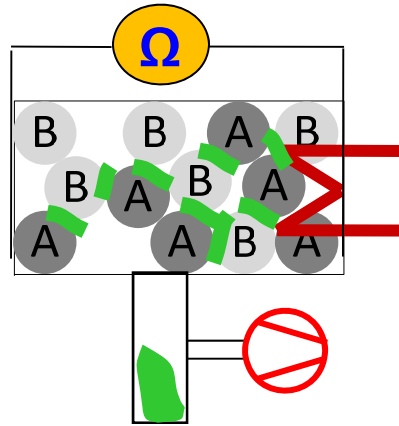

container 1

container 2

evacuation system

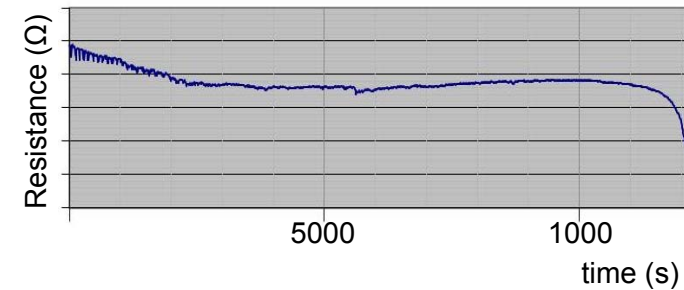

# Validation for low temperature system

- Known System<sup>1</sup> of K,Li,Na//NO<sub>2</sub>,NO<sub>3</sub>
- Starting with non-eutectic mixture (red DSC line)
- Heating to “start of melting temperature” (solidus)
- Extraction of liquid phase
- Composition of extracted mixture is eutectic (blue DSC line)

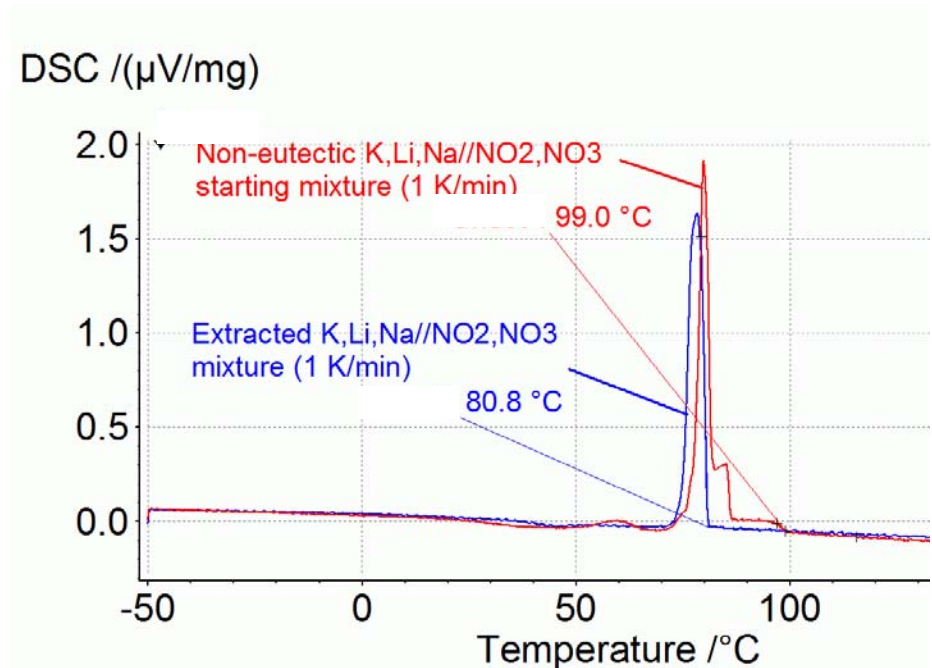

-J.G. Cordaro, N.C. Rubin, M.D. Sampson, R.W. Bradshaw (2010) *Multi-Component Molten Salt Mixtures based on*

-*Nitrate/Nitrite Anions*, Paper presented at the Solar Paces, 21.-24. Sep., Perpignan, France



## Results for high temperature systems:

- Chloride :NaCl-KCl-MgCl<sub>2</sub> (24-21-55) <sup>(1),(2)</sup>

Melting temperature	Heat capacity	Thermal conductivity	density
393°C	1 J/gK	0.95 W/ mK	1 800 kg/m <sup>3</sup>

- Carbonate: Li<sub>2</sub>CO<sub>3</sub>-Na<sub>2</sub>CO<sub>3</sub>-K<sub>2</sub>CO<sub>3</sub> (43.5-31.5-25) <sup>(3)</sup>

Melting temperature	Heat capacity	Thermal conductivity	density
397°C	1.63 J/gK	2.02 W/ mK	2140 kg/m <sup>3</sup>

- (1) Murat M. Kenisarin (2010) High-temperature phase change materials for thermal energy storage
- (2) G.J. Janz, R.P.T. Tomkins: Physical Properties Data Compilations Relevant to Energy Storage. IV. Molten Salts: Data on Additional Single and Multi-Component Salt System
- (3) M.Geyer (1990) A feasibility study on thermal energy storage for commercial applications



# Conclusions

Storage media for high temperature applications:

- Chloride systems/ Carbonate systems (400 °C - 800 °C)
- Further investigations required for lower  $T_{\text{melt}}$

$\text{Cl}^-$

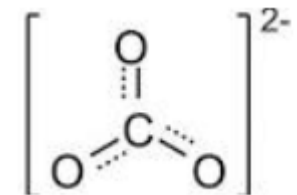

Methods for reducing melting temperature:

- High throughput method
- Extraction-by-vakuum method (to be extended for high T)

