

Digital Beamforming And Multidimensional Waveform Encoding for Spaceborne Radar Remote Sensing

Gerhard Krieger, Nicolas Gebert, Alberto Moreira

Microwaves and Radar Institute, German Aerospace Center (DLR), 82234 Oberpfaffenhofen, Germany

Gerhard.Krieger@dlr.de

Abstract— This paper introduces the innovative concept of multidimensional waveform encoding for space-borne synthetic aperture radar (SAR). The combination of this technique with digital beamforming on receive enables a new generation of SAR systems with improved performance and flexible imaging capabilities. Examples are high-resolution wide-swath radar imaging with compact antennas, enhanced sensitivity for applications like along-track interferometry and moving object indication, or the implementation of hybrid SAR imaging modes which are well suited to satisfy hitherto incompatible user requirements. Implementation specific issues will be discussed and performance examples demonstrate the potential of the new technique for different remote sensing applications.

I. INTRODUCTION

Digital beamforming on receive is a promising technique to overcome fundamental limitations of conventional radar systems [1]. For example, the unambiguous swath width and the achievable azimuth resolution pose contradicting requirements on SAR system design. This limitation can be overcome by splitting the receiving antenna into multiple sub-apertures [2-4]. In contrast to analog beamforming, the signals of each sub-aperture element are separately amplified, down-converted, and digitized. This enables an a posteriori combination of the recorded sub-aperture signals to form multiple beams with adaptive shapes. The additional information about the direction of the scattered radar echoes can then be used to (1) suppress spatially ambiguous signal returns from the ground, (2) to increase the receiving gain without a reduction of the imaged area, (3) to suppress spatially located interferences, and (4) to gain additional information about the dynamic behaviour of the scatterers and their surroundings.

This paper complements the technique of digital beamforming on receive by the concept of multidimensional radar waveform encoding. The combination of both techniques has high potential to improve the performance and flexibility of future SAR systems [5]. For this, we analyse in Sect. II the signal reception in a multi-aperture SAR from an information theoretic point of view. Sect. III introduces then the concept of multidimensional radar waveform encoding. The paper is closed in Sect. IV with a short discussion about application potentials of the new technique.

II. MULTI-APERTURE SIGNAL RECEPTION

A promising application of digital beamforming on receive is high resolution wide swath SAR imaging [2-4]. This technique uses a small transmit antenna to illuminate a large footprint on the ground. The scattered signal is then received by a large antenna array which allows for a combination of the displaced phase centre technique in azimuth with

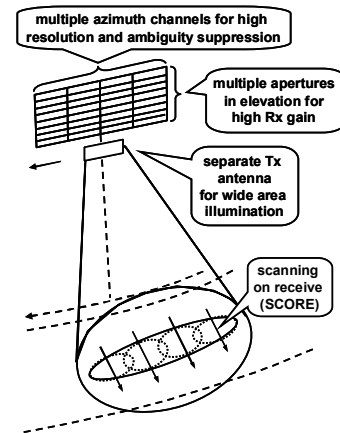

Fig. 1: High resolution wide swath (HRWS) SAR [4].

beamsteering in elevation (Fig. 1). The displaced phase centre technique is used to gain additional samples along the synthetic aperture which enables an efficient suppression of azimuth ambiguities. The beamsteering in elevation is used to improve the SNR without a reduction of the swath width by following the radar pulses in real time as they travel on the ground.

A. Multi-Channel SAR Processing

The application of the classical displaced phase centre (DPC) technique in a high resolution wide swath (HRWS) SAR system puts a stringent requirement on the pulse repetition frequency (PRF): the PRF has to be chosen such that the SAR platform moves just one half of the total antenna length between subsequent radar pulses. This requirement is due to the fact that the phase centres of the additional samples from the multi-aperture antenna must exactly fit in between the satellite's travelled distance between two transmit pulses to yield a uniformly sampled synthetic aperture. However, such a rigid selection of the PRF may be in conflict with the timing diagram and it will furthermore exclude the opportunity to increase the PRF for improved azimuth ambiguity suppression. To avoid such restrictions, a new reconstruction algorithm has been developed in [6] which allows for the recovery of the unambiguous Doppler spectrum even in case of a non-uniform DPC sampling. The derivation of this reconstruction algorithm is based on modelling the raw data acquisition in a multi-aperture SAR by a linear multi channel systems model where each channel describes the SAR data acquisition of one antenna element. The reconstruction assumes a limitation of the Doppler bandwidth $B_{\text{Dop}} \leq N \cdot \text{PRF}$, where N is the number of receiver channels. A violation of this condition causes again ambiguous returns as detailed in

[7]. Such residual ambiguities can be mitigated by an additional beamforming prior to signal recording. For example, beamforming on transmit can be used to obtain refined antenna patterns with a better limitation of the Doppler spectrum. Another opportunity is pre-beam shaping on receive. Here, the basic idea is to form multiple beams by combining the signals from overlapping sub-groups of receiving antenna elements prior to A/D conversion. This enables again a better sidelobe suppression and furthermore an adaptation of the position of the effective phase centers, thereby improving the signal reconstruction [8].

B. Information Content and Data Compression

An independent recording of the signals from a large antenna array with multiple sub-aperture elements results in a huge amount of data samples which exceeds in general by far the number of independent pixels in the final image. The recorded signals will hence be redundant, and their mutual information can be regarded as being composed of two components (Fig. 2). The first component arises from the short duration of the transmitted radar pulse which limits the extension of the instantaneous scattering field on the ground. This area restriction causes a strong spatial correlation among the signals from the different antenna elements. The second component is an additional temporal correlation which can be understood if we imagine the formation of a narrow beam covering only a part of the instantaneous scattering field. Assuming now a radar pulse with linear frequency modulation, only a part of the total range bandwidth will be visible at each instant of time, thereby introducing a temporal correlation among the samples of the recorded signal.

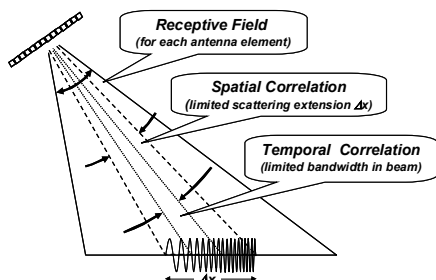

Fig.. 2: Redundancy of recorded multi-aperture data

Both the temporal and the spatial correlation can in principle be exploited by sub-sampling the signals from the antenna array. However, a mere sub-sampling in space and time would increase the noise level due to noise aliasing (but no signal alias!), thereby losing the opportunity for coherent averaging. An efficient exploitation of the redundancies requires hence a spatio-temporal transformation of the recorded antenna signals which projects the useful signal energy onto a sub-space of the total data volume. An example for such a transformation is scanning on receive (SCORE) as suggested for the HRWS system in [4]. This technique combines the signals from all antenna elements in elevation to form a narrow beam which follows the radar pulse as it travels on the ground. This is achieved by selecting the scan angle as a function of range time. The drawback of this direct coupling is that important information may irreversibly be lost during data recording. For example, iso-range elevation changes in

mountainous terrain will cause a reduced antenna gain due to erroneous beam pointing. A simple calculation shows that this effect may not be neglected for a spaceborne X-band system with an antenna height exceeding one to two meters (Fig. 3).

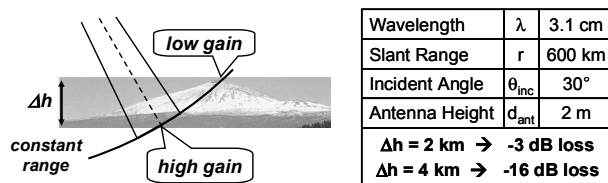

Fig.. 3: Gain loss from topography during pulse chasing

A first solution to this problem is the formation of multiple narrow beams and an adaptive selection of the data from the beam with maximum output power, but this poses still the problem that there may exist strong topography changes within the extension of the azimuth footprint. An alternative is partial beamforming which combines only a subset of the antenna elements. The outputs are then combined by predictive coding and/or a joint (polar) quantization exploiting residual redundancies between the signals from the beams. Optimized quantizers with minimum data rate can be derived from a rate distortion analysis and a multi-beam vector quantization could even use a dynamic bit assignment with variable bit rate which reflects the actual information content recorded by the large antenna array.

III. MULTIDIMENSIONAL WAVEFORM ENCODING

The applications in the previous section assume a wide area illumination by a dedicated transmit antenna. This enables an independent optimization of the transmit and receive paths, but it requires also an additional antenna and reduces the flexibility to operate the radar system in different modes like ultra-wide swath ScanSAR, high SNR spotlight, or new hybrid modes to be discussed later. It is hence worth to consider also the application of digital beamforming techniques in radar systems which use the same large antenna array for both transmit and receive, taking advantage of the already existing T/R modules technology. The use of a large Tx aperture for a high resolution wide swath imaging system poses in turn the question of how to distribute the signal energy on the ground. The trivial solution would be amplitude tapering, or as an extreme case, the use of only a part of the transmit antenna, but this causes a significant loss of efficiency. Another solution is phase tapering, but the derivation of appropriate phase coefficients is a complex task requiring in general numerical optimization techniques [9,10].

A completely different approach to exploit the large antenna array is the use of spatio-temporally non-separable waveforms for each transmitted pulse. Such multi-dimensional waveforms can e.g. be obtained by dividing long transmit pulses into multiple sub-pulses and switching the sub-aperture phase coefficients between the sub-pulses. An alternative is the use of separate waveform generators for the sub-apertures (Fig.4).

A simple example for a non-separable waveform encoding in space and time is a mere switching between different antenna beams during *each* single transmit pulse. The overall PRF remains unaltered in this case. Since many of the

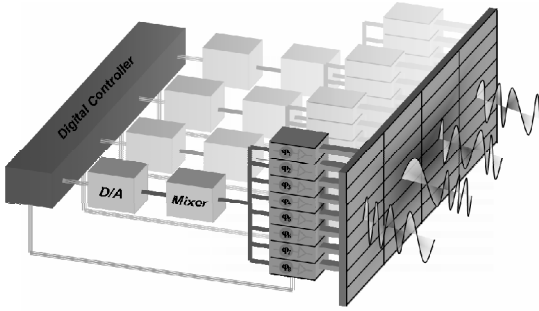

Fig. 4: Transmitter for 3-D spatio-temporal radar pulse encoding with four azimuth waveform generators and intra-pulse elevation beam-steering.

previously mentioned applications rely on a rather low PRF, the concatenation of multiple sub-pulses to a long pulse poses no technical problem. Full range resolution within each beam is achieved by concatenating multiple chirp signals in a sawtooth like temporal modulation (or any other sequence of full bandwidth and possibly orthogonal waveforms). The advantage of such a scheme is that it may allow the staggered illumination of a large footprint during one pulse, thereby supporting a systematic distribution of the available signal energy among the footprint (Sect. III.A). A further advantage is the opportunity for improved ambiguity suppression due to the reduced antenna beamwidth for each sub-pulse (Sect. III.B). The concept can of course be extended to an arbitrary spatio-temporal radar illumination where each direction has its own temporal transmit signal with different power, bandwidth, and phase code. The selection of the spatiotemporal excitation coefficients could even be made adaptive by evaluating previously recorded samples. By this, a closed loop will be formed between the sensor and the environment, which allows for a maximization of the information content (or “radar channel” capacity) for a given RF power budget. The following subsections illustrate some opportunities arising from such a spatio-temporal radar signal encoding.

A. Intra-Pulse Beamsteering in Elevation

One example for multi-dimensional waveform encoding is intra-pulse beam steering in elevation. This enables an illumination of a wide image swath with a sequence of narrow and high gain antenna beams. The illumination sequence can in principle be arranged in any order. An interesting opportunity arises if we start from a far range illumination and proceed subsequently to near range. As a result, the radar echoes from different sub-swaths will overlap in the receiver (Fig. 5). The overall receiving window can hence be shortened, thereby reducing the amount of data to be recorded on the satellite. On the other hand, the spatial data redundancy discussed in Sect. II is substantially reduced, since the receiver obtains now radar echoes from multiple directions simultaneously. The staggered illumination enables hence an efficient data compression without the necessity of expensive on-board processing. The overlapping radar echoes from the different sub-swaths are then separated in the spatial domain by digital beamforming on receive. This a posteriori processing can be performed on the ground, which has the further advantage that no information about the spatial structure of the recorded data will be lost, thereby enabling e.g. a suppression of directional interferences and avoiding the mountain clipping problem of real-time beam scanning.

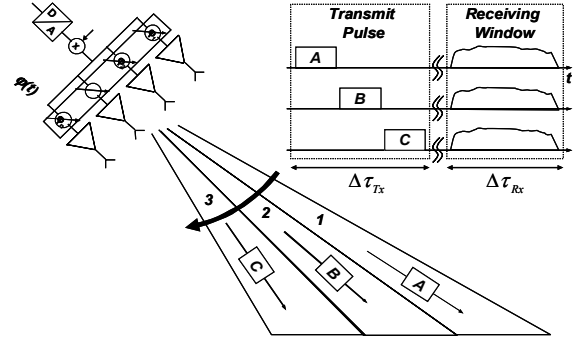

Fig. 5: Intra-pulse beamsteering in elevation

There exist several opportunities to implement the required Tx beamsteering in elevation. One solution would be to use different parts of the long antenna array for each beam, thereby ensuring a low duty cycle for each T/R module notwithstanding the long transmit pulse. In the limit, each T/R module needs only one preloaded phase coefficient, and the beamsteering is implemented by a mere on/off switching between different T/R modules. Another solution is to use the full antenna array for the total pulse length, which has the advantage to reduce the peak power requirements for each T/R module. The illumination is then achieved either by switching between phase tapered beams or via a continuous beamsteering from far range to near range. The latter requires appropriate temporal modulation such that each scatterer receives sufficient bandwidth for full range resolution.

B. Non-Separable Azimuth Waveforms

Spatial modulation diversity in the radar transmitter can increase the information about the direction of a given scatterer. A simple example is a multi-aperture antenna where each aperture transmits its own orthogonal waveform (Fig. 4). The orthogonality of the signals facilitates a separation of the radar echoes for a given scatterer on the ground and the spatial diversity of the transmit phase centers causes a relative phase shift between the received waveforms. This additional information can then be used to suppress ambiguous returns from point targets or to increase the sensitivity to object movements by evaluating systematic phase changes between the orthogonal radar echoes. On a first sight, such a modulation may also be well suited to reduce the azimuth ambiguities in a SAR system. However, the mere use of orthogonal waveforms will only disperse the ambiguous energy, thereby making this approach only suitable for the attenuation of ambiguous returns from point-like targets.

A suppression of ambiguous returns from distributed targets can be obtained by combining the spatial transmit diversity with digital beamforming on receive. For this, multiple narrow azimuth beams will be formed in the transmitter, thereby reducing the associated Doppler bandwidth in the receiver channels. A sequence of chirp signals is then transmitted while switching between the azimuth beams from sub-pulse to sub-pulse (Fig. 6, left). This results in a relative time shift of the radar echoes from each azimuth beam, which translates to a difference in elevation if one considers the simultaneously arriving signals from different sub-pulses. This beam vs. range ambiguity can now be resolved by digital beamforming on receive in elevation, thereby enabling a clear separation of the

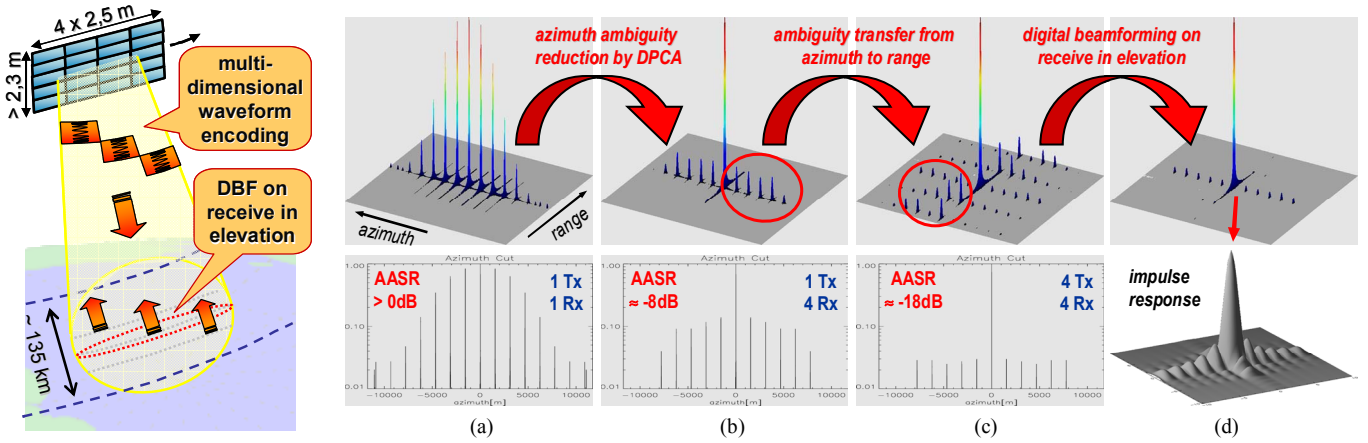

Fig. 6: Multidimensional waveform encoding in azimuth. Left: Staggered illumination by multiple narrow azimuth beams. Right: Transfer of ambiguous energy from azimuth to range. (a) impulse response from one transmitter and one receiver. (b) azimuth ambiguity suppression by four receive channels. (c) ambiguity transfer from azimuth to range by intra-pulse azimuth beamsteering. (d) range ambiguity suppression by digital beamforming on receive.

received echoes from different azimuth beams [5]. The echoes from multiple azimuth beams can now be combined to recover the full Doppler spectrum for high azimuth resolution. This processing is equivalent to a signal reconstruction from a multi-channel bandpass decomposition.

As an example we consider an X-band system with a spatial resolution of 1.5m and a swath width of 135km, which enables a ‘continuous’ observation of the Earth with a 20 days repeat cycle at an altitude of 576km. A continuous observation is e.g. desired for permanent scatterer interferometry. Assuming an incident angle range of 30° to 40° and a transmit pulse with three azimuth beams of $3 \times 50\mu\text{s}$, the PRF has to be lower than 1220Hz and the antenna height has to be in the order of 2.5m to ensure a reliable separation between the multiple radar echoes by digital beamforming on receive. The right hand side of Fig. 6 shows the transfer of the ambiguous energy from azimuth to range assuming a $4 \times 2.5\text{m}$ antenna with four azimuth channels and a processed bandwidth of 5000 Hz. It becomes clear that the ambiguity suppression is significantly improved by using non-separable transmit waveforms, thereby allowing for wide coverage and/or smaller antennas.

IV. CONCLUSIONS

The combination of spatio-temporal radar waveform encoding and digital beamforming on receive is an innovative concept which enables new and very powerful SAR imaging modes for a wide range of remote sensing applications. Examples are improved performance and ambiguity suppression, moving object indication, as well as redundancy reduction in large receiver arrays. The opportunity for beamforming on transmit enables furthermore a flexible distribution of the transmitted RF signal energy on the ground, which allows for the combination of different imaging modes like a simultaneous high resolution spot-light like mapping of areas of high interest in combination with a simultaneous wide swath mapping (Fig. 7). Such a hybrid mode is well suited to satisfy otherwise contradicting user requirements like e.g. the conflict between a continuous interferometric background mission and a high resolution data acquisition request within a wide incident angle range. The data acquisition could even be made adaptive where more system resources are devoted to areas of high interest and/or low SNR, thereby maximizing the

information content for a given RF power budget. This can be regarded as a first step towards a cognitive radar which directs its resources to areas of high interest in analogy to the selective attention mechanisms of the human visual system with its saccadic eye movements. The interest in such systems is also well documented in the recent literature [11].

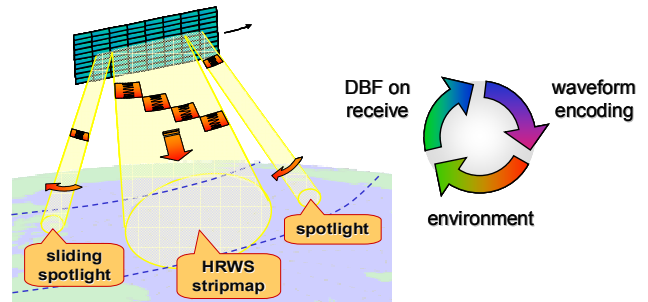

Fig. 7: Hybrid and adaptive SAR imaging modes.

REFERENCES

- [1] W. Wiesbeck, *SDRS: software-defined radar sensors*, IGARSS 2001, Sydney, Australia.
- [2] N. Goodman, D. Rajakrishna, J. Stiles, *Wide swath, high resolution SAR using multiple receive apertures*, IGARSS 1999, Hamburg, Germany.
- [3] G. Callaghan, I. Longstaff, *Wide-swath space-borne SAR using a quad-element array*, IEE Radar Sonar Navig., vol. 146, pp. 159-165, 1999.
- [4] M. Suess, B. Grafmueller, R. Zahn, *A novel high resolution, wide swath SAR system*, IGARSS 2001, Sydney, Australia.
- [5] G. Krieger, N. Gebert, A. Moreira, *Multidimensional Waveform Encoding: A New Digital Beamforming Technique for Synthetic Aperture Radar Remote Sensing*, to appear in IEEE Trans. Geoscience and Remote Sensing, 2007.
- [6] G. Krieger, N. Gebert, A. Moreira, *Unambiguous SAR signal reconstruction from nonuniform displaced phase center sampling*, IEEE Geosc. Remote Sens. Letters, vol. 1, pp. 260-264, 2004.
- [7] N. Gebert, G. Krieger, A. Moreira, *High Resolution Wide Swath SAR Imaging with Digital Beamforming - Performance Analysis, Optimization and System Design*, EUSAR 2006, Dresden, Germany.
- [8] N. Gebert, G. Krieger, A. Moreira, *Digital Beamforming on Receive: Techniques and Optimization Strategies for High Performance SAR Imaging*, submitted to IEEE Trans. Aerospace Science and Technology, 2007.
- [9] G. Kautz, *Phase-only shaped beam synthesis via technique of approximated beam addition*, IEEE Trans. Ant. Prop., vol. 47, pp. 887-894, 1999.
- [10] A. Trastoy, F. Ares, E. Moreno, *Phase-only control of antenna sum and shaped patterns through null perturbation*, IEEE Ant. ennas and Propagation Magazine, vol. 43, pp. 45-54, 2001.
- [11] F. Gini, "Knowledge-Based Systems for Adaptive Radar [Guest Editorial]," IEEE Signal Processing Magazine, vol. 23, pp.14-17, 2006.