



IOMAC'17

7th International Operational Modal Analysis Conference
2017 May10-12 Ingolstadt - Germany

NEW CONCEPTS FOR GROUND AND FLIGHT VIBRATION TESTING OF AIRCRAFT BASED ON OUTPUT-ONLY MODAL ANALYSIS

M. Böswald¹, J. Schwochow², G. Jelacic², Y. Govers³

¹ Head of Department Structural Dynamics and System Identification, DLR - German Aerospace Center, Institute of Aeroelasticity, Göttingen, Germany, marc.boeswald@dlr.de

² Research Assistant, Department of Structural Dynamics and System Identification, DLR - German Aerospace Center, Institute of Aeroelasticity, Göttingen, Germany

³ Team Leader Modal Testing and Model Validation, Department of Structural Dynamics and System Identification, DLR - German Aerospace Center, Institute of Aeroelasticity, Göttingen, Germany

ABSTRACT

In this paper, recent advances in ground vibration testing and flight vibration testing of aircraft as applied at DLR, the German Aerospace Center, are presented. The new methods are based on output-only modal analysis and have been developed with specific focus on efficient certification of experimental aircraft operated by DLR. Quite often these aircraft are modified to fulfill scientific missions, e.g. installation of equipment for atmospheric research in wing stores, modification of aircraft aerodynamics or aircraft systems for drag and weight reduction, etc. For this reason, DLR is interested in the development, maturation and application of advanced test methods for ground vibration testing and flight vibration testing, because the selection of the test method has strong impact on the cost for certification and the availability of the aircraft for the intended scientific missions.

Keywords: ground vibration testing, taxi vibration testing, flight vibration testing, online monitoring, parameter-varying systems

1. INTRODUCTION

DLR is the German governmental research establishment for aeronautics, space, energy and transport. To support research activities, DLR is operating a fleet of research aircraft shown in Figure 1, which is used for the development, demonstration and maturation of aircraft technology but also for conducting atmospheric research with flying measurement platforms. To fulfill scientific missions, the DLR research aircraft quite often are modified by installation of scientific equipment on the aircraft. For the certification of such modifications, DLR has its own Design Organization taking care of demonstrating compliance of the modified research aircraft with existing airworthiness requirements.



Figure 1. Fleet of DLR research aircraft based in Braunschweig (left) and in Oberpfaffenhofen (right).

For obtaining a permit to fly of a newly developed aircraft or a modified aircraft, it is required that natural frequencies and mode shapes be determined in a ground vibration test (GVT). Furthermore, it has to be shown by rational analysis that the aircraft is free from aeroelastic instability such as flutter, divergence or control reversal within the whole flight envelope. Finally, absence of flutter is verified in a flight vibration test (FVT) by demonstrating sufficient amount of damping of the aircraft modes of vibration at any point within the flight envelope.

The balance between cost and effort is always involved when demonstrating compliance with certification requirements for modifications of existing aircraft. Does every modification require a full GVT as if a new aircraft prototype is being certified? Is a cross-check of the variation of some eigenfrequencies and damping ratios to a reference dataset of the unmodified aircraft sufficient? The certifying staff of the DLR Institute of Aeroelasticity is quite often confronted with such questions. Therefore, a systematic research for efficient test procedures for demonstrating compliance with certification requirements for research aircraft with modifications was proposed in the year 2006 and has been followed since then.

2. EFFICIENT METHODS FOR GROUND VIBRATION TESTING OF AIRCRAFT WITH MODIFICATIONS

The core of the research campaign started in 2006 was to provide experimental modal parameters of modified aircraft in an equivalent way but with application of completely different test processes and analysis methods compared to a conventional GVT. The benefits of using of output-only modal analysis came quite early into the focus of the research, inspired by the publication of James, Carne and Lauffer in [1] and taking into account the 2005 state-of-the-art of methods in operational modal analysis applied in time- and frequency-domain as reported by Zhang, Brinker and Andersen in [2].

The Taxi-Vibration-Test (TVT) method was one of the milestones in the research for alternative procedures for GVT. The basic idea of TVT is to make use of the natural excitation as the aircraft is rolling on uneven pavement (i.e. taxiway). This is illustrated, for example, in the sketch on the left hand side of Figure 2. Provided that acceleration sensors are installed on the airframe and that a data acquisition system is available e.g. inside the cabin of the aircraft, the dynamic response of the airframe excited by the unknown forces induced by driving on the taxiway can be used in an output-only modal analysis scheme to extract eigenfrequencies, damping ratios and mode shapes of the aircraft. Even though it is not possible to identify a mathematical forecast model of the test object (i.e. scaled modes will not be available), the results obtained are sufficient for correlation with numerical models and for validation afterwards.

2.1. First Laboratory Tests on a Replica of the GARTEUR Benchmark Structure

This idea has first been investigated in the year 2006 on a rather low technology readiness level (TRL) on laboratory scale. A landing gear has been designed for a replica of the GARTEUR benchmark structure SM-AG19. The replica of this well-known structure is named AIRMOD and is used within DLR e.g. for the validation of methods. This structural model of an aircraft with landing gear has been placed on a conveyor belt equipped with artificial bumps and potholes. This is illustrated on the right hand side of Figure 2. The major research objective was to find out whether or not a complete set of mode shapes with corresponding eigenfrequencies and damping ratios can be identified compared to a

regular GVT on that structure. Another research objective was to determine the influence of the driving speed on the magnitude of the responses and also on the upper frequency limit sufficiently excited. The results of these laboratory tests are summarized in [3]. As reported there, an almost complete set of modes had been identified from TVT and compared to GVT results. In fact, 28 modes have been identified from the conveyor belt TVT setup compared to a GVT conducted by shaker testing in the frequency range up to 400Hz. Just one mode could not be identified from the TVT which has been identified in the GVT. The frequency-spatial domain decomposition technique has been applied for operational modal analysis, see e.g. [4]. This is a variant of the frequency domain decomposition (FDD) method presented in [5]. It uses the matrix of power-spectral densities (PSD matrix) as an input calculates spectra of singular values of that matrix to be used for identification of eigenfrequencies and mode shapes. Damping ratios are identified by employing frequency-domain single degree of freedom (DoF) curve-fitting techniques applied to the PSD matrix of the recorded operational responses.

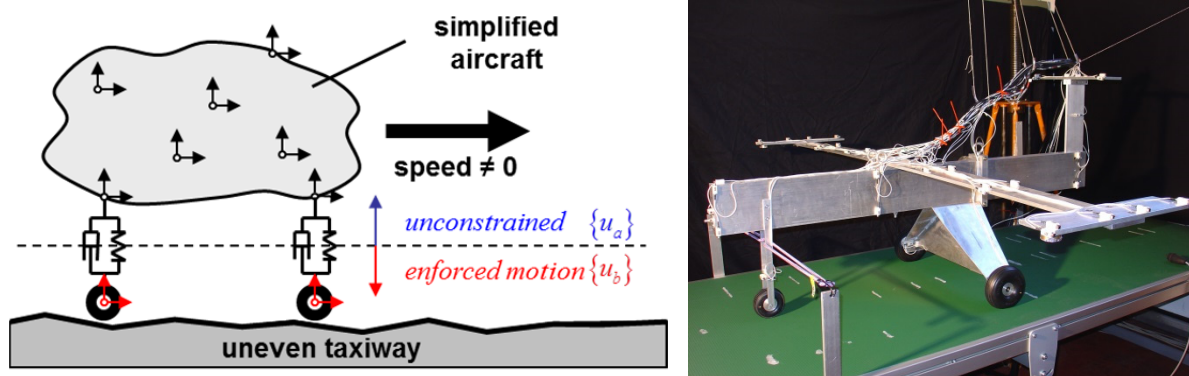

Figure 2. Aircraft simplified as a dynamic system with enforced motion at base DoF (left), AIRMOD with landing gears on conveyor belt to investigate the TVT approach for the first time (right).

2.2. Verification of the TVT approach on the Commuter Class Aircraft Do228

The amount and the quality of the results obtained from the TVT on the GARTEUR structure were quite promising, so that further investigation of the method on a representative application was envisaged. Consequently, in the year 2008, a TVT has been performed on a Do228 commuter class aircraft – one of DLR's research aircraft, see Figure 3.



Figure 3. Taxi vibration test on Do228 commuter class aircraft pulled by a tractor in front of the old DLR flight operations hangar in Braunschweig, Germany

One of the key objectives of that campaign was to study under which test conditions (driving speed, fuel configuration, artificial bumps on the taxiway, distance between artificial bumps, engines on/off, nitrogen pressure in shock absorbers, etc.) the method performs well and yields acceptable results in terms of accuracy and quantity. To this end, an approach for the mathematical modelling of an aircraft rolling on uneven taxiway was developed in order to assess the influence of structural parameters

(mass distribution, landing gear properties) and test parameters (driving speed, obstacles) on the response of the aircraft and on the observability of mode shapes and eigenfrequencies. The principle of dynamic response analysis of structures with base excitation as used in earthquake engineering has been adopted here and is sketched on the left hand side of Figure 4.

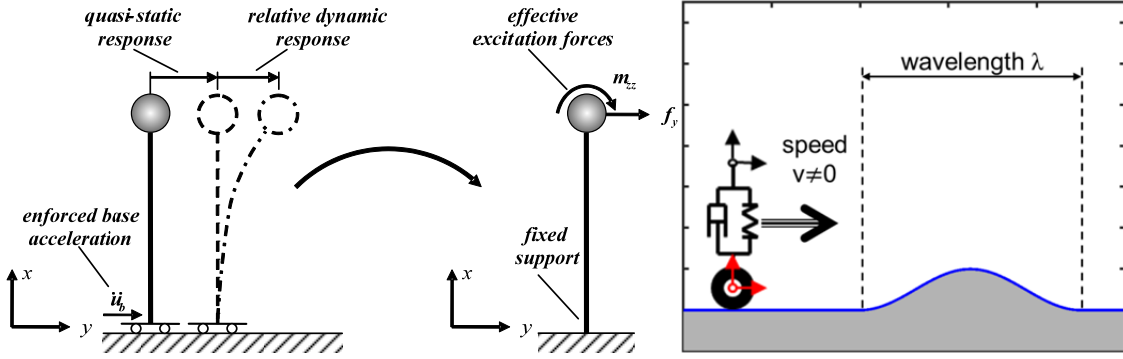

Figure 4. Modelling of base excitation of dynamic structures (left) and bump on taxiway (right)

The key element in the modelling approach is that the total response is separated into quasi-static response due to deflection of the support DoFs plus a relative dynamic response excited by equivalent effective excitation forces. The relative dynamic response can be considered as if the effective excitation forces were acting on a system with fixed support DoFs. The analysis requires the partitioning of the whole system into unconstrained DoFs (index a) and DoFs with enforced motion (index b); see for example the sketch on the left hand side of Figure 2.

$$\begin{bmatrix} M_{aa} & M_{ab} \\ M_{ba} & M_{bb} \end{bmatrix} \begin{Bmatrix} \ddot{u}_a \\ \ddot{u}_b \end{Bmatrix} + \begin{bmatrix} C_{aa} & C_{ab} \\ C_{ba} & C_{bb} \end{bmatrix} \begin{Bmatrix} \dot{u}_a \\ \dot{u}_b \end{Bmatrix} + \begin{bmatrix} K_{aa} & K_{ab} \\ K_{ba} & K_{bb} \end{bmatrix} \begin{Bmatrix} u_a \\ u_b \end{Bmatrix} = \begin{Bmatrix} 0 \\ 0 \end{Bmatrix}$$

The quasi-static response $\{u_a\}^{static}$ can be determined from the enforced base motion $\{u_b\}$ when the stiffness matrix of the overall system is known.

$$\{u_a\} = \{u_a\}^{static} + \{u_a\}^{rel}$$

$$\{u_a\}^{static} = -[K_{aa}]^{-1}[K_{ab}]\{u_b\} = [T_G]\{u_b\}, \quad \{\dot{u}_a\}^{static} = [T_G]\{\dot{u}_b\}, \quad \{\ddot{u}_a\}^{static} = [T_G]\{\ddot{u}_b\}$$

The relative dynamic response is calculated for the unconstrained DoFs by using the equivalent effective excitation forces. It can be seen that the properties of the landing gears are represented in the coupling matrices $[M_{ab}]$, $[C_{ab}]$, and $[K_{ab}]$, respectively.

$$[M_{aa}]\{\ddot{u}_a\}^{rel} + [C_{aa}]\{\dot{u}_a\}^{rel} + [K_{aa}]\{u_a\}^{rel} = \{f_{eff}\}$$

$$\{f_{eff}\} = \left([M_{aa}][K_{aa}]^{-1}[K_{ab}] - [M_{ab}] \right) \{\ddot{u}_b\} + \left([C_{aa}][K_{aa}]^{-1}[K_{ab}] - [C_{ab}] \right) \{\dot{u}_b\}$$

Next to the mathematical modelling of the system, an approach for the modelling or understanding of the unknown excitation was developed. In general, the surface roughness of the taxiway is unknown. However, when considering that just one taxiway is being used, the spectrum of the unknown excitation can be influenced by the driving speed v . When considering a taxiway with a single 1-cos bump passed at driving speed v , the equivalent excitation frequency Ω can be introduced and the time domain equation of motion can be transferred into the frequency domain (neglecting non-linearities).

$$\{\hat{f}_{eff}(j\Omega)\} = \left[-\Omega^2 \left([M_{aa}][K_{aa}]^{-1}[K_{ab}] - [M_{ab}] \right) + j\Omega \left([C_{aa}][K_{aa}]^{-1}[K_{ab}] - [C_{ab}] \right) \right] \{\hat{u}_b(j\Omega)\}$$

$$\lambda = vT = v \frac{1}{f} = v \frac{2\pi}{\Omega} \rightarrow \Omega = \frac{1}{2\pi} \frac{v}{\lambda}$$

The equivalent frequency of excitation Ω is a function of the driving speed v and the wavelength λ representing the size of a typical 1-cos obstacle on the taxiway. It can be seen, that the higher the driving speed, the higher the equivalent frequency excited. However, when taking into account that the energy of the excitation is limited, it becomes obvious that the broader the spectrum of the excitation (i.e. the higher the equivalent frequency), the lower the magnitude of that spectrum.

With the mathematical modelling of the dynamic system and the equivalent modelling of the unknown excitation, the planning of the taxi-vibration-test on the Do228 was started. In total, 80 acceleration sensors have been installed all over the aircraft. The corresponding cables were glued by adhesive tape to the structure and routed to the data acquisition system installed inside the cabin. For the study of the influence of test parameters, driving with different speeds on the rather flat runway, on uneven taxiway and special track prepared with wooden obstacles was performed. In addition, pulling by a tractor and with engine thrust was investigated. “Engines-on” with prepared track could not be tested, because the obstacles were just lying on the taxiway without fixation, so that dispersed parts might damage the aircraft.

The results of that campaign are summarized in [6]. In summary, 23 modes were identified from TVT up to 40 Hz compared to 28 modes from conventional GVT performed afterwards on the same configuration. For data analysis an operational least-squares complex frequency-domain (LSCF) algorithm was applied, see e.g. [7]. This method calculates time-domain correlation functions between all recorded responses and some selected references. These functions are essentially exponentially decaying sinusoids similar to impulse response functions and can be transformed into the frequency domain using an exponential window. The main advantage of the operational LSCF method over the FDD method is that the amount of artificial damping from the window-functions can be determined analytically so that the final damping estimates do not suffer from signal processing parameters.

The 5 modes that could not be identified from TVT are 2 rigid body modes and 3 modes of the control system (which cannot be excited from TVT for aircraft with manual control system in case of control surfaces with mass balance). Even though the modal dataset obtained was quite complete and the quality was convincing, it was the first time that differences between GVT results and TVT results showed up for low-frequency modes involving the landing gear shock absorbers, see Figure 5.

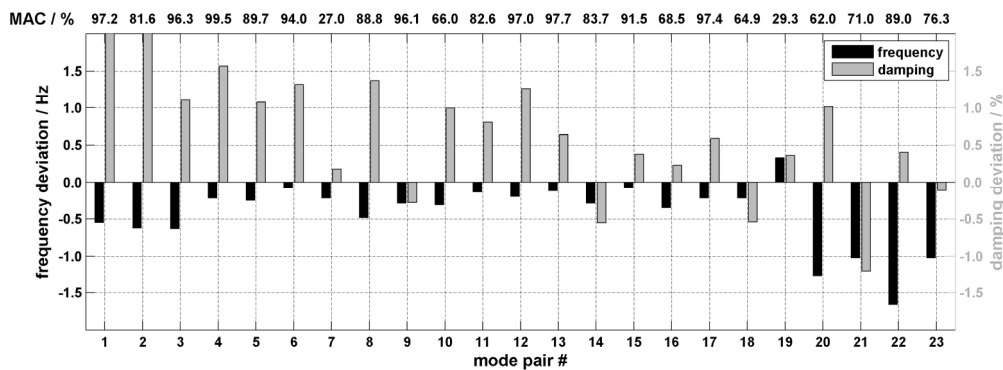

Figure 5. Frequency deviation and damping deviation of correlated modes from GVT and TVT

The reason for this systematic deviation could be explained from reviewing the amplitude dependent behaviour of single DoF systems with friction dampers and elastic springs. During the GVT, the shaker excitation was not sufficient to drive the shock absorbers of the landing gear out of their sticking friction mode (i.e. stiff with little damping), whereas in the TVT while driving over obstacles and bumps, the landing gear is most of the time in the sliding friction mode (less stiff with strong damping). This non-linear effect is displacement amplitude dependent at the shock absorber location and resulted in an increase of damping of low frequency modes in combination with a decrease of the eigenfrequencies due to the decrease of stiffness when the shock absorbers are in sliding friction. As a lesson learned from this campaign, instrumentation was developed enabling the measurement of the relative dynamic deflection of the shock absorbers during taxiing. In addition, adverse effects of the pilot talking to the airport manager using radio equipment were detected. These only affected the measurements with the engines switched on. However, for subsequent campaigns this effect should be

avoided by using differential voltage measurements. The duration of the response recording have also been reviewed after the campaign. 600 seconds of recording has been used in this case. It is difficult to assess whether or not a longer recording time could have yield better results. Therefore, it was decided for subsequent projects to use longer recoding times so that the influence of that test parameter on the modal parameters obtained can be estimated.

2.3. Taxi Vibration Test on a Short Range Large Transport Aircraft A320-200

Based on the good results from the Do228 TVT and taking into account the lessons learned, it was decided to demonstrate the applicability of the TVT method on an Airbus A320 aircraft. In 2009, a common DLR and Airbus TVT campaign was conducted at the Technical Center for Aircraft and Aeronautical Equipment (WTD 61) of the German Armed Forces in Manching, Germany.

Due to restrictions in the electric power supply, a VXI data acquisition system with a maximum of 160 channels has been installed inside the aircraft cabin. In total, 138 acceleration sensors distributed all over the aircraft have been recorded together with the dynamic deflection of the landing gear shock absorbers measured by means of draw wire sensors, the angular deflection of the control surfaces and some aircraft operational parameters such as rotational speeds of the engine shafts, speed over ground, wind speed, GPS position, static pressure, ambient temperature, fuel capacity, aircraft center of gravity, etc. Since the mass distribution on the unconstrained DoFs $[M_{aa}]$ affects the unknown excitation, different fuel configurations were studied, for example, center wing tank fully fueled and wing tip tanks fully fueled or completely empty. Three different driving speeds v were investigated to vary the base excitation $\{\dot{u}_b\}$ and $\{\ddot{u}_b\}$. The highest driving speed could only be reached with engines switched on. Since the objective was to identify the modal parameters of the aircraft structure, influence of motion induced aerodynamic forces are to be kept minimal. To this end, the driving speed was restricted to a maximum of 30 km/h. In order to overcome the problem of short recording times as happened in the Do228 application, a continuous recording of 45 minutes was performed in every test configuration. The driving distance can easily reach 20 km or more during such a long TVT run. That posed some problems for the prepared runway tests. Wooden obstacles as can be seen in Figure 6 were placed on the taxiway. A circuit of 600 m length was prepared. In order to cover the 20 km distance during one TVT run, about 30 to 40 laps have to be conducted. Figure 6 also shows that the preparation was made only for the main landing gears; an unprepared slot was retained for the nose landing gear. The reason was the tractor, whose driver was not willing to go over the obstacles – not for convenience reasons but for safety reasons of the drawbar connection to the nose landing gear. After each TVT run of 45 minutes duration, the center wing tank was refueled. That was done for the sake of mass consistency, because the amount of fuel consumed by the auxiliary power unit (APU) during the 45 minutes was significant.



Figure 6. Taxi Vibration Test on the DLR research aircraft ATRA, an A320-200

The operational modal analysis was performed in the frequency range up to 35 Hz. In total, 8 out of the 138 acceleration sensors were selected as reference sensors for the calculation of PSDs or

respectively time-domain correlation functions. The method applied was like in the Do228 case performed using operational LSCF. In addition to the TVT, a GVT was performed with the aircraft on tires, i.e. same conditions as in the TVT. Two different fuel configurations were considered in the reference GVT. Again, the involvement of the landing gear can be observed when comparing the low frequency modes of the TVT with those of the GVT. Even with phase resonance testing in GVT, when using multiple powerful shakers, it was not possible to bring the landing gear shock absorbers out of their sticking friction mode. Just in case of the aircraft rigid body pitch mode the nose landing gear shock absorber went into sliding friction mode at higher force levels. For the other modes in the lower frequency range, the large vibration amplitudes as seen in the TVT could not be achieved in the GVT. For the higher frequency modes, the modal excitation is reduced more and more. The reason can also be found in the effective excitation force vector whose spatial distribution is mainly governed by the mass distribution $[M_{aa}]$ of the unconstrained DoFs of the airframe. In case of equal mass distribution, this results in quasi equally distributed excitation forces that are unable to excite e.g. higher wing bending modes that have multiple nodes of vibration (i.e. points of zero displacement) in span-wise direction. Nonetheless, modes have been identified whose primary deformation directions are orthogonal to the excitation direction. For example, the wing fore-aft bending modes have been identified quite well. They have been excited whenever the aircraft brakes.

An excerpt of the TVT results on the A320 aircraft are reported in a paper of a German national vibration conference [8]. Due to confidentiality reasons, detailed numbers for eigenfrequencies and damping ratios cannot be given for this test. On average, about 35 mode shapes were identified per reference sensor (i.e. column of the PSD matrix) and per TVT configuration. After correlation of the results from different reference sensors, 46 different modes were identified in average per TVT configuration in the frequency range up to 35 Hz.

One TVT run has been performed twice in order to study the reproducibility of the test results. The correlation of the results of the two runs is presented on the left hand side of Figure 7 in terms of modal assurance criterion (MAC) of the identified mode shapes. The MAC matrix shows a predominant diagonal structure with some perturbations. In the one TVT run, 40 modes were identified, whereas the other TVT run comprises only 34 modes. The data of the two runs has been processed independently by different operators. It is most likely that a close inspection of the 40 modes from the TVT run 2 would indicate that some modes have been identified by mistake. In particular, the modes of the landing gear had a poor MAC correlation among the two datasets. Taking into account that the landing gear is a non-linear component of the aircraft puts the results into a better perspective. Nonetheless, validation of modal analysis results can be an issue in case of operational modal analysis. One of the most powerful quality indicators typically applied for the validation of experimental modal analysis results is to check for excessive values (high or low) of the generalized mass and of the modal damping. Since operational modal analysis is applied here, the generalized mass is not available and the validation of the identified modal data is more delicate.

In order to assess the potential of the TVT to provide data for the validation of a finite element model, the correlation of a TVT run with a reference GVT dataset has been performed. The corresponding MAC correlation is shown in the right hand side of Figure 7. In the frequency range up to 35Hz, 46 modes were identified in the GVT and 38 modes in the TVT. When focussing on the frequency range up to 15 Hz typically used for finite element model validation of large transport aircraft, it can be stated that there are only 2 modes from the GVT that could not be identified in the TVT; a higher bending mode of the wing and an engine roll mode. Nonetheless, there is a big gap in the MAC matrix around modes 20 to 25. These are landing gear modes that can be identified in the TVT but not in the GVT. Furthermore, it is anticipated that the dissipation of the MAC correlation beyond the 25 Hz limit is due to the lack of modal excitation of higher modes having higher number of waves. Such modes cannot be excited well by base excitation as stated before.

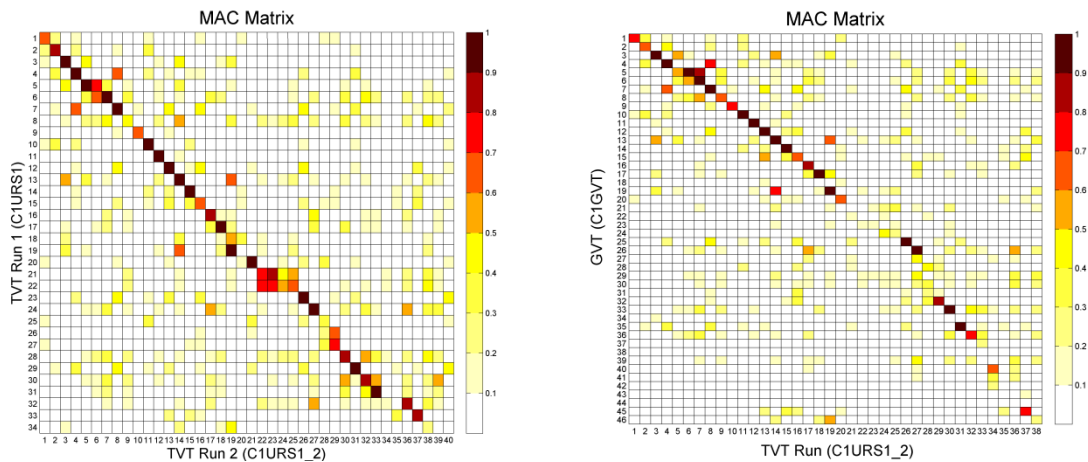

Figure 7. Correlation of the results of two TVT runs to check for reproducibility (left); correlation of the results from a reference GVT with TVT (right)

From the correlation of TVT runs with different driving speeds and with prepared or unprepared track it can be concluded that the influence on the results of operational modal analysis of the driving speed and preparation of the track is rather limited – even though the impact of these test parameters on the root-mean-square (RMS) value of the response amplitudes is significant. On the other hand, it is a justification of the 45 minutes recording time which, from a statistics point of view, provides sufficient excitation for nearly all modes of interest. Just a minority of modes found in the GVT were so weakly excited in the TVT that they could not be identified from the operational response data. This conclusion on the influence of driving speed and preparation of the track was made on the basis of the modal analysis results of the full response recording of 45 minutes. It is anticipated, however, that in case of shorter recording times the influence of these two test parameters will grow.

2.4. Taxi Vibration Test on a Long Range Large Transport Aircraft A340-600

In order to further mature the method to reach technology readiness level (TRL) 6, the TVT has been applied to an A340-600 in the year 2011, see Figure 8. It is one of the Airbus research aircraft and the test has been performed on the Airbus premises in Toulouse near the Blagnac airport. The data acquisition system was installed in multiple mainframes inside the cabin. In total, 594 response channels have been recorded plus additional channels comprising landing gear deflections, control surface rotations and relevant aircraft operational parameters – quite similar to the TVT on the A320-200 as reported above.



Figure 8. Taxi Vibration Test on an A340-600 long range aircraft at Airbus in Toulouse

The scope and objectives of this TVT were to demonstrate that a database of experimental modal data for finite element model validation can be acquired using this concept. Due to the knowledge from the A320-200 TVT it was not necessary to perform TVT runs with different fuel configurations or different configurations of the taxiway: just one fuel configuration was considered and no preparation of the runway with obstacles. Pulling the aircraft with a tractor was sufficient, i.e. engines remained

switched off all the time. In total, 3 different TVT runs with 3 different driving speeds were conducted within one day. Each run had duration of 60 minutes with continuous recording of the operational responses of all response channels. In between the TVT runs, refuelling of the center wing tank was performed to compensate the fuel burn of the APU which provided the electrical power for aircraft operation and for the measurement system. The results of this TVT campaign are confidential and are reported in a DLR internal report available only to Airbus and DLR.

It should be noted here, however, that this TVT featured a very dense instrumentation with acceleration sensors. In particular, some specific components were installed with a very high number of sensors. This applies to the racks of the avionic systems below the cockpit, the nose landing gear and the left hand side main landing gear. With more than 40 sensors on the left hand side main landing gear and more than 20 sensors on the nose landing gear, very detailed modal identification of the landing gear modes was possible. The boundary conditions for the landing gear modal identification are representative for the real aircraft operation including the stiffness of the tires, the shock absorbers driven out of their sticking-friction mode, the gyroscopic effects of the rotating wheels, etc. Simulation of such boundary conditions in ground vibration test inside a hangar cannot be achieved easily. Thus, the TVT provides useful information for nose landing gear stability analysis (so-called shimmy analysis).

3. DEVELOPMENT OF A FRAMEWORK FOR MONITORING OF PARAMETER-VARYING SYSTEMS BASED ON PERMANENT REAL-TIME OUTPUT-ONLY MODAL ANALYSIS

In the previous chapters the DLR developments for efficient methods for ground vibration testing of aircraft have been described. In the TVT campaigns on the A320-200 and on the A340-600 operational modal analysis was performed using commercial software with an operational LSCF type of algorithm. This commercial software required intensive operator interaction and was not suited for automated data analysis with preset analysis parameters. Therefore, DLR decided to develop its own software toolbox for experimental and operational modal analysis. The requirement of minimal operator interaction was requested next to high software performance and speed of analysis. The first version of that MATLAB-based toolbox became available in the first half of the year 2014. The performance time of the modal analysis algorithm was so impressive – the whole processing from time-domain data to modal parameters took less than a second for a representative dataset – that real-time modal analysis and later on permanent (i.e. continuous) real-time modal analysis were formulated as requirements for the first time.

The first idea for the application of permanent real-time modal analysis was taxi vibration testing of large aircraft. As reported before, operational response data of about one hour must be recorded, afterwards the data is analysed offline. A mistake in the setup can harmfully affect the success of a TVT campaign, e.g. when detected late in the offline data analysis phase. Since there is a risk of not being able to recover the test setup (because the instrumentation is refurbished after the TVT and the aircraft is scheduled for some other task) it would make sense to get first estimates of modal parameters while the TVT is still ongoing. Comparing frequencies and mode shapes with expectations or even simulation results during the TVT would help to mitigate the risk of such a campaign.

However, the availability of a permanent real-time modal analysis tool is the key enabler for the monitoring of time-varying or parameter-varying systems. In fact, a flying aircraft is a parameter-varying system whose modal parameters vary with flight speed, flight altitude (i.e. air density) and fuel capacity. In a flight vibration test, it must be demonstrated that the aircraft is free from aeroelastic instabilities such as flutter, divergence or control reversal. Especially flight flutter testing requires monitoring of the changes of damping ratios and eigenfrequencies to maintain safety. Permanent real-time operational modal analysis was identified as a key competence for the conduction of flight vibration testing.

At constant flight conditions, the flying aircraft may exhibit non-linearity in the response characteristics, i.e. due to the unsteady aerodynamic forces become non-linear when flying at

transonic conditions or because of the control systems that are potentially non-linear due to freeplay and/or friction in the control surface actuation system. Nonetheless, an assumption is being introduced here that the aircraft can be considered as linear and time-invariant (LTI) at constant flight conditions. When considering the flight envelope with a range of different flight conditions (i.e. combinations of flight speed and flight altitude) and operational conditions (i.e. fuel capacity, engine rotational speeds, setting of high-lift devices and landing gears, etc.), the aircraft is no longer an LTI system but becomes a linear parameter-varying (LPV) system. Furthermore, it is assumed that changes in the governing parameters (flight speed, flight altitude, fuel burn, etc.) are introduced slowly so that within a few seconds of typical measurement time required for modal identification the aircraft can be approximated by an LTI system. However, when a number of such short time measurements are conducted over a longer time period while operational parameters change significantly, changes in the modal parameters can be observed and monitored. Extrapolation of these changes towards the next coming flight conditions, for example the stepwise increase of flight speed in fixed flight altitude, is an approach to detect critical aeroelastic instability with sufficient early warning. The approach towards a flutter critical speed shall be indicated by monitoring software that detects the trend that some damping ratio observed over several past flight conditions will critically approaching zero within the next coming flight conditions.

The DLR toolbox for permanent real-time modal analysis was systematically developed to serve this approach for flight vibration testing. The requirement in terms of robustness and accuracy are quite high and maturation of the software cannot be achieved by flight testing. Therefore, the first application of the toolbox was monitoring of the vibrations of an elastically suspended 2D aerofoil wind tunnel model able to perform heave and pitch motion, see the sketch in Figure 9. The theory of the first modal identification algorithm of the DLR toolbox is published in [9] and [10]. It is based on an operational LSCF type of algorithm, quite similar to the one of the commercial software used for the TVTs, but fully automated, much faster and with the ability to operate continuously in an infinite loop.

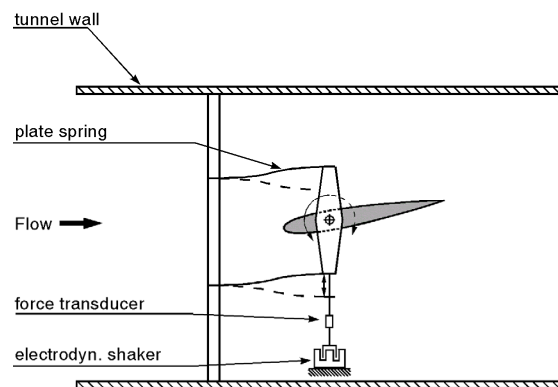

Figure 9. Elastically suspended 2D aerofoil with heave and pitch motion

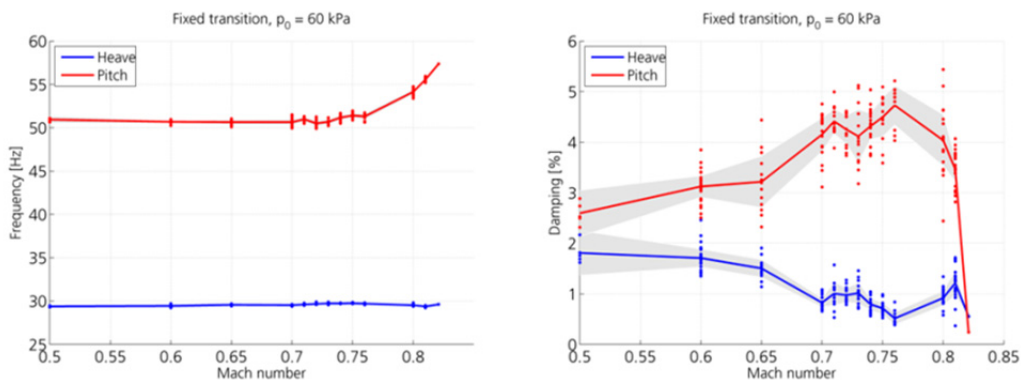

Figure 10. Variation of eigenfrequency and damping ratio of heave and pitch mode with Mach number at constant static pressure conditions, scatter of identified values, and confidence intervals

In the wind tunnel test, the identification of modal parameters was conducted at discrete Mach numbers as can be observed in the diagrams of Figure 10. The corresponding scatter in the identified parameters can be observed and the 95% confidence intervals are plotted in grey around the mean values of the respective parameters. The confidence interval being narrow for the eigenfrequencies but broad for the damping ratios is in agreement with the findings presented in [11].

Modal parameter estimation can be performed in time-domain or in frequency-domain and the pros and cons of the corresponding estimators are known to the community. In order to have in addition independent estimates from a time-domain estimator, an algorithm based on stochastic subspace identification (SSI, see e.g. [12]) has been developed and implemented. The implementation was designed in a way that both estimators, the LSCF and the SSI, can operate simultaneously on the same data in parallel. In particular, the problem of finding the suitable model order and the construction of stabilization diagrams when using SSI type of algorithms was addressed in the development. The theoretical background and the strategy for selecting poles are presented in [13]. For the demonstration and maturation of the SSI algorithm an application to random response data from a multi-point random excitation run conducted within the scope of a ground vibration test on a sailplane has been performed. In addition, the offline application of this SSI algorithm to replayed operational response data recorded in a previous flight vibration test of the DLR HALO research aircraft is presented in [13].

Critical to the success of the application of operational modal analysis in flight vibration testing is sufficient broad band excitation. To a certain extent, natural turbulence is always present and provides a certain level of excitation. The so-called von Karman spectrum, see e.g. [14], is a statistical mathematical model for continuous turbulence in the atmosphere. The von Karman spectrum as a natural source of random excitation of aircraft has been investigated in [15]. To this end, a numerical aeroelastic model of a sailplane has been placed in a flow field with superimposed natural turbulence according to the von Karman spectrum. The velocity of the incoming undisturbed flow was gradually increased, which corresponds to a numerical simulation of a flight test in bumpy air, and the numerical response data of only 16 selected DoFs has been submitted to DLR's output-only modal analysis toolbox. It was demonstrated by this investigation in [15], that the von Karman spectrum of the natural turbulence provides sufficient excitation to identify the relevant modes of a sailplane. It was also demonstrated that the modal parameters of the simulated aeroelastic system known a priori can be identified from the simulated time-domain acceleration response including the flutter critical condition with zero damping ratio of one of the contributing modes. This confirms the suitability of the developed output-only modal analysis toolbox for the identification of in-situ modal parameters – a key enabler for the indication of the stability margins of aeroelastic systems.

For permanent modal identification, a robust interface to a data acquisition system is required. DLR decided to separate the data acquisition task from the data analysis task: the MATLAB-based analysis software is running on one or more PCs that use the COM/ActiveX interface to the PC in the same local area network (LAN) performing the data acquisition. The benefit of this architecture is that it is not dependent on specific data acquisition hardware or software, thus, the online modal analysis technology can be connected to existing data acquisition systems for monitoring purposes. In addition, the data analysis task can run on multiple PCs with different analysis settings for the same data source. The concept and the architecture of the DLR permanent real-time modal analysis hardware and software for flutter monitoring during flight vibration testing is described in more detail in [16].

In addition, permanent modal analysis will permanently provide modal analysis results. These must be stored together with the corresponding combination of operational parameters, environmental parameters, but also signal processing parameters and analysis settings that fully describe the conditions under which the modal parameters were obtained. In this case, an SQL database originally used for storing GVT data and results was adapted and serves now as a data source for the online generation of stability charts similar to the diagrams shown in Figure 10.

4. EFFICIENT TESTING FOR CERTIFICATION OF RESEARCH AIRCRAFT WITH MODIFICATIONS

DLR has developed the permanent real-time modal analysis software for efficient ground and flight vibration testing of aircraft. A recent application of this concept including the hardware and software is the ground and flight vibration test campaign on the DLR HALO (High Altitude and Long duration) aircraft, a Gulfstream G550 with modifications, e.g. to carry scientific instrumentation under the wings for atmospheric research, see Figure 11.



Figure 11. DLR HALO aircraft with particle measurement system (PMS carrier) installed under the wing

The certifying staff of the DLR-Institute of Aeroelasticity has to demonstrate the compliance with the certification specifications for this experimental aircraft – in this case CS-25 of the European Aviation Safety Agency (EASA) is to be applied. First of all, it is required to identify the natural frequencies, the mode shapes and the damping ratios of the aircraft with modification on ground. Afterwards, it has to be demonstrated by aeroelastic simulation (e.g. flutter analysis) that the modified aircraft is free from aeroelastic instability such as flutter, divergence, or control reversal. Finally, if this can be demonstrated by simulation, the permit to fly is granted to start the flight testing. In order to perform the required GVT and FVT in an efficient manner, it was planned from the very beginning to use one and the same instrumentation for both tests. This makes the TVT an excellent candidate for obtaining the modal parameters on ground.

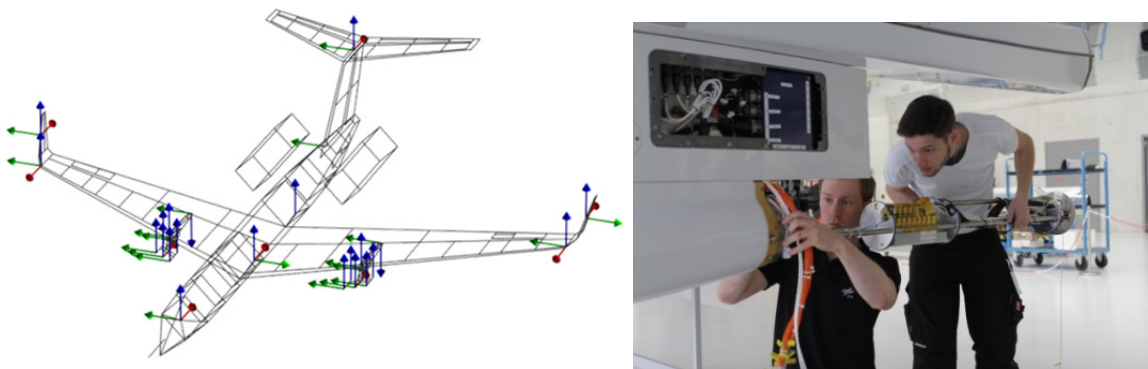

Figure 12. Instrumentation with acceleration sensors for TVT and FVT of the DLR HALO aircraft

This combination of TVT and FVT required also that all sensor installation and cable routing be performed in a way that the aerodynamics of the aircraft is not adversely affected. Therefore, the sensors and the cables were installed inside the aircraft behind aerodynamic fairings, i.e. on front spar or rear spar of the wing behind the leading edge fairing or trailing edge fairing, etc. The so-called particle measurement system (PMS) – carriers for scientific equipment installed under both sides of the wing – were also equipped with sensors inside the structure. About 50 acceleration sensors plus strain gauges have been used. All of them have been selected with low thermal sensitivity because they have to function over a wide range of ambient temperatures in ground testing and flight testing. The measurement DoFs used for the TVT and the FVT are shown on the left hand side of Figure 12. It is well suited to observe global aircraft deformation but also local deformation of the PMS carrier

installation. The data acquisition system features a distributed architecture with 3 individual but synchronized acquisition units: the master unit was installed inside the aircraft cabin, the two slave units were installed in left and right PMS carrier outside the pressurized cabin in cold temperatures and low ambient static pressure. On the right hand side of Figure 12 the data acquisition system and the corresponding mechanical adapter for the fixation of the acquisition unit inside the central canister of the PMS carrier is depicted (also shown in Figure 11).

The TVT on HALO was conducted on the DLR premises in Oberpfaffenhofen near Munich (see Figure 13) and the results are reported in [17]. The engines remained switched off and the aircraft was pulled by a tractor, the APU provided all the electrical power for the aircraft systems and also for the data acquisition system, the aircraft was fully fueled. Since TVT and FVT were intended to use the same acquisition hardware and software, the former was employed as a means for checking the functionality of the whole processing chain. In total, 4 portable PCs were installed in the cabin, all in the same LAN and connected to an Ethernet switch. The first PC was controlling the acquisition systems and storing the measured data onto the hard disk drive for subsequent offline analysis. The second and the third PC performed the real-time operational modal analysis, with operational LSCF and SSI in parallel, stored the modal data with the corresponding operational conditions in an SQL database, and permanently updated the flutter stability diagrams as new modal data are stored in the SQL database. The fourth PC was reserved for checking the functionality of the processing chain.



Figure 13. TVT on HALO on the DLR premises in Oberpfaffenhofen

An excerpt of typical operational responses during the TVT is given in Figure 14. The random nature of the data can be directly observed. It is interesting to note the different response levels in different phases of taxiing, e.g. driving on the bumpy taxiway, the smooth runway and the turn with reduced driving speed. The data obtained from 60 minutes of taxiing was used for operational modal analysis. Some of the modes identified are shown in Figure 15 comprising aircraft rigid body modes, symmetric and anti-symmetric modes of the airframe and local modes of the PMS carrier installation. For confidentiality reasons, the eigenfrequencies and damping ratios cannot be given here.

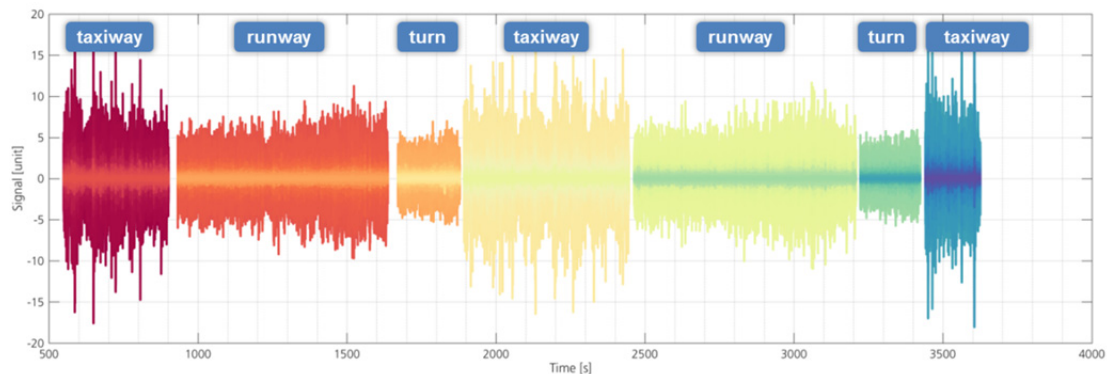

Figure 14. Operational response data during different phases of taxiing

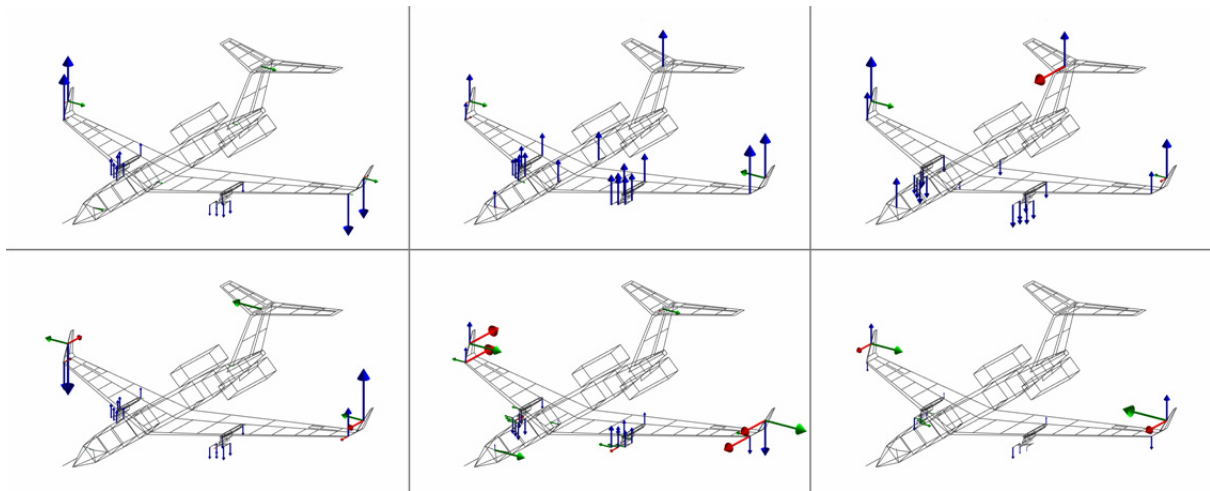

Figure 15. Mode shapes of HALO with PMS carrier identified using TVT

The TVT on HALO was performed in one afternoon after all flight test equipment has been installed. That TVT also served as a functionality check for the whole instrumentation to be used later on for the FVT. The TVT results confirmed the eigenfrequencies and mode shapes that were identified in a ground vibration test campaign performed in the year 2009. Flutter analysis has been performed with the modal data of the original GVT campaign. The conclusion of the flutter analysis was that no flutter critical situation is likely to occur, so that the permit to fly was immediately provided and making it possible to start the first flight of the FVT campaign directly the day after the TVT.

During the flight testing, it was intended to study operational modal analysis using different sources of excitation. According to the investigations described in [15], the use of natural excitation by atmospheric turbulence (i.e. von Karman spectrum) was envisaged. In addition, pilot induced commands to the control surfaces were to be investigated; the so-called stick-raps. It is crucial for the success of the approach based on operational modal analysis that broad band random-like excitation is available. To properly meet this assumption, the pilot was asked to introduce impulsive commands into the control column with random sequence of elevator, ailerons, and rudder. Furthermore, the time intervals between successive pilot inputs also varied randomly. The last source of excitation to be investigated was the turbulent wake of the DLR Falcon aircraft flying about 1 km ahead of the DLR HALO aircraft. Even though one could not see the chase aircraft, the effect of the turbulent wake was quite significant and well suited for operational modal analysis. This can be observed in the time-histories of the acceleration responses shown in Figure 16. Whenever the pilot flies into the turbulent wake, a significant increase of the random-like vibration response of the aircraft can be observed. At the beginning of this part of the flight test program (i.e. around the time of 1500s in the diagram of Figure 16), the pilot had some difficulties entering the wake. It should be noted here that the wake is not visible to the pilot but its proper location had to be detected in several trials. Later on, the process worked quite well and a significant amount of excitation was provided.

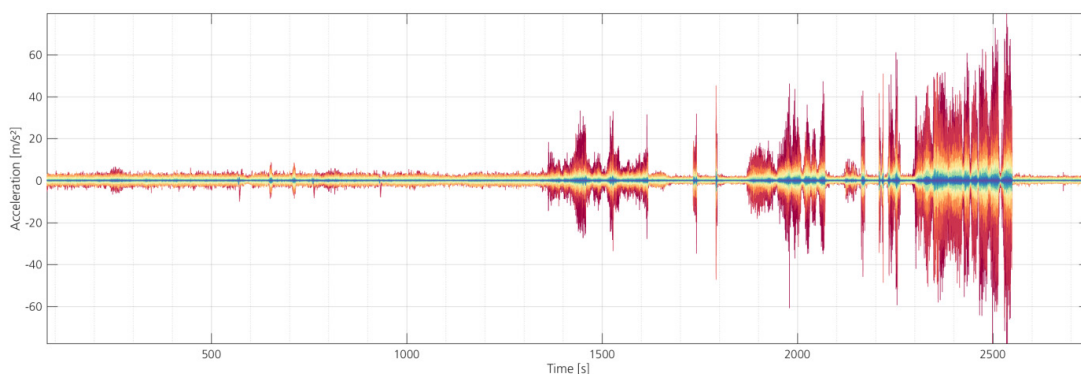

Figure 16. Response levels recorded during FVT with natural turbulence excitation and with turbulent wake of chase aircraft

While the vibration responses were being recorded, the flight conditions of the aircraft changed in a systematic manner to cover the full flight envelope. During the whole flight test time, the permanent real-time operational modal analysis was running. It provided, for example, diagrams like the one shown in Figure 17. It can be seen that the variation of the damping ratios is much more pronounced than the variation of the eigenfrequencies. It should also be mentioned, that buffering of data is required to achieve the required frequency resolution in the spectral data. To this end, the permanently varying Mach number (red line in the upper diagram of Figure 17) is filtered by this “moving-average data buffer” so that the black line is the average Mach number for which modal parameters are stored in the database.

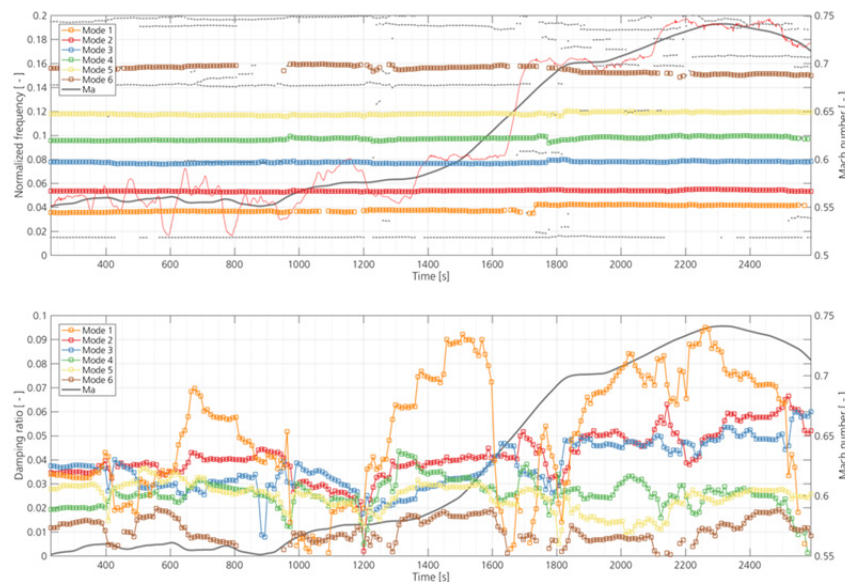

Figure 17. Variation of eigenfrequencies (upper diagram) and damping ratios (lower diagram) with Mach number (black line)

While the pilot was progressing with the flight testing, the test engineers communicated with the pilot to inform him about the actual damping ratios and the extrapolated flutter stability margin. In this case, discrete points in the flight envelope were approached to perform modal identification. For future FVT, however, the whole process will be more interactive. Uncritical regions of the flight envelope, where the aircraft is sufficiently stable, can be cleared faster using a fast increase of the flight speed. More delicate regions, where there is indication that damping of some aircraft modes is gradually dropping, can be cleared slower with a slower increase of the flight speed. When making use of this close interaction of the pilot and the flight test engineer, the duration and the cost of flight vibration test campaigns can be reduced significantly contributing to efficient certification.

5. CONCLUSIONS

The development of new test concepts for aircraft ground vibration testing and flight vibration testing based on output-only modal analysis methods has been presented. The basic idea of the taxi vibration test (TVT) method was introduced and the applications for the systematic investigation of the effectiveness of the method were presented. The maturation of the TVT has gradually been achieved by application to use cases of different complexity. This is a prerequisite for the TVT method to be acknowledged by certification authorities such as EASA or FAA but also by aircraft manufacturers as an accepted means for demonstrating compliance with certification requirements. With demonstration of the TVT to applications relevant to the aircraft industry – in this case to large transport aircraft such as A320-200 and A340-600 – the technology readiness level (TRL) 6 has been reached.

With increasing complexity of the application, large amounts of TVT data must be processed and finally the request for automated operational modal analysis tools emerged. As a solution to this, DLR developed a toolbox for experimental and operational modal analysis. The excellent performance of

the modal parameter estimators implemented in that toolbox enabled enhancements toward real-time modal analysis and later on even towards permanent real-time modal analysis. The availability of such a technology is the key enabler for monitoring of time-varying and parameter-varying systems. But when addressing real-time modal analysis, the effectiveness of parameter estimators alone is not sufficient. Coupling to data acquisition hardware is required in the same way as the connection to a database that can store the ever growing amount of results together with visualization tools providing online displays of stability charts showing the evolution of essential analysis results with operational parameters.

The effectiveness of the combination of taxi vibration test and flight vibration test has been demonstrated on behalf of the DLR HALO aircraft. In particular when testing for certification of aircraft with modifications (in contrast to testing of newly developed aircraft) is addressed, it can be concluded that the TVT is best choice in consideration of cost for certification and quality of the results.

What are the remaining difficulties and challenges in this test concept? In the Do228 application, the systematic deviation in damping ratio and eigenfrequency of low frequency modes caused by the non-linear friction-damper like characteristic of the landing gear shock absorbers has been pointed out. The measurement of the shock absorber dynamic relative deflection has been performed in case of the A320-200 and in case of the A340-600. The systematic correction of the modal analysis results e.g. by incorporating a dynamic shock absorber model – either an equivalent linear model or a fully non-linear model – is a challenging task reserved for future research activities. However, the benefit of a method that can provide this correction is considered to be as high as the technical difficulty in the development of it.

A perspective for interactive flight vibration testing has been given by the end of chapter 4. This will be the focus of future research activities at DLR but requires that well-established processes have to be revisited. The quality of the results alone will not be sufficient to initiate a change in the way that flight vibration testing is performed. This can only be achieved by demonstrating a significant benefit in cost savings.

6. ACKNOWLEDGEMENTS

The authors gratefully acknowledge the contribution of the members of the Department of Structural Dynamics and System Identification at the DLR Institute of Aeroelasticity, namely, Ralf Buchbach, Julian Sinske, Julian Springer, Bernd Will, Holger Haupt and Tobias Meier. The research presented here would not have happened without their enthusiasm and passion for aircraft technology and vibration research. In addition, the support of the colleagues from the DLR Flight Experiments in Braunschweig and in Oberpfaffenhofen is gratefully acknowledged: Gerald Ernst, Stefan Seydel, Steffen Gemsa, Martina Hierle, and Sebastian Burwitz. Furthermore, we would like to thank the DLR Program Directorate for Aeronautics in making it possible for us to use the DLR research aircraft for this specific methods development. Finally, we would like to thank our cooperation partners at Airbus Deutschland for the support in our research activities. In particular we thank Bernd Schulze and Michael Kordt, who permanently challenged us to improve our tools and methods. Without such high targeted objectives, we would have never come so far.

REFERENCES

- [1] G.H. James, T.G. Carne, J.P. Lauffer. *Modal Testing using Natural Excitation*. Proceedings of the 10th International Modal Analysis Conference (IMAC), San Diego, California, 1992
- [2] L.M. Zhang, R. Brinker, P. Andersen. *An Overview of Operational Modal Analysis: Major Developments and Issues*. Proceedings of the International Operational Modal Analysis Conference (IOMAC), Copenhagen, Denmark, 2005
- [3] M. Boeswald, Y. Govers, D. Goege, L. Zhang. *Identification of Modal Parameter of Aircraft during Taxi*. Proceedings of the 26th International Modal Analysis Conference (IMAC), Orlando, Florida, 2008

- [4] L.M. Zhang, T. Wang, Y. Tamura. *Frequency-spatial Domain Decomposition Technique with Application to Operational Modal Analysis of Civil Engineering Structures*. Proceedings of the International Operational Modal Analysis Conference (IOMAC), Copenhagen, Denmark, 2005
- [5] R. Brinker, L.M. Zhang, P. Andersen. *Modal Identification from Ambient Response using Frequency Domain Decomposition*. Proceedings of the 18th International Modal Analysis Conference (IMAC), San Antonio, Texas, 2000
- [6] M. Böswald, Y. Govers. *Taxi Vibration Testing – An Alternative Method to Ground Vibration Testing of Large Aircraft*. Proceedings of the International Conference on Noise and Vibration Engineering ISMA2008, Leuven, Belgium, 2008
- [7] B. Peeters, A. Vecchio, H. Van der Auweraer. *PolyMAX modal parameter estimation from operational data*. Proceedings of the International Conference on Noise and Vibration Engineering ISMA2004, Leuven, Belgium, 2004
- [8] M. Böswald, Y. Govers. *Taxi Vibration Test – Die Anwendung von Output-Only Modalanalyse für Standschwingungsversuche großer Flugzeuge*. VDI-Berichte 2093, VDI Fachtagung Schwingungsanalyse & Identifikation, Leonberg, Germany, 2010
- [9] G. Jelcic, J. Schwochow, Y. Govers, A. Hebler, M. Böswald. *Real-time assessment of flutter stability based on output-only modal analysis*. Proceedings of the International Conference on Noise and Vibration Engineering ISMA2014, Leuven, Belgium, 2014
- [10] G. Jelcic, J. Schwochow, Y. Govers, A. Hebler, M. Böswald. *Fast online monitoring and system identification for the application in the field of aeroelasticity*. Proceedings of ICoEV 2015, Ljubljana, Slovenia, 2015
- [11] M. Böswald. *Analysis of the bias in modal parameters obtained with frequency-domain rational fraction polynomial estimators*. Proceedings of the International Conference on Noise and Vibration Engineering ISMA2016, Leuven, Belgium, 2016
- [12] P. Van Overschee, B. De Moor. *Subspace Algorithms for the Stochastic Identification Problem*. Automatica 29(3), 1993
- [13] J. Schwochow, G. Jelcic. *Automatic Operational Modal Analysis for Aeroelastic Applications*. Proceedings of the International Operational Modal Analysis Conference (IOMAC), Gijon, Spain, 2015
- [14] F.M. Hoblit. *Gust Loads on Aircraft: Concepts and Applications*. AIAA Education Series, 1988
- [15] J. Schwochow, M. Böswald, G. Jelcic. *Überwachung von Flugschwingungsversuchen mit operationeller Modalanalyse*. VDI-Berichte 2259, VDI Fachtagung Schwingungsanalyse & Identifikation, Fulda, Germany, 2016
- [16] G. Jelcic, J. Schwochow, Y. Govers, J. Sinske, , R. Buchbach, J. Springer, M. Böswald. *Online Monitoring of Aircraft Modal Parameters during Flight Test based on permanent Output-only Modal Analysis*. AIAA Paper 2017-1825, Proceedings of the 58th AIAA/ASCE/AHS/ASC Structures, Structural Dynamics, and Materials Conference, AIAA SciTech Forum, Grapevine, Texas, 2017
- [17] Y. Govers, J. Sinske, J. Schwochow, G. Jelcic, R. Buchbach, J. Springer, M. Böswald. *Efficient ground vibration testing of aircraft based on output-only modal analysis during taxi*. AIAA Paper 2017-1824, Proceedings of the 58th AIAA/ASCE/AHS/ASC Structures, Structural Dynamics, and Materials Conference, AIAA SciTech Forum, Grapevine, Texas, 2017